

POPULAR SCIENCE

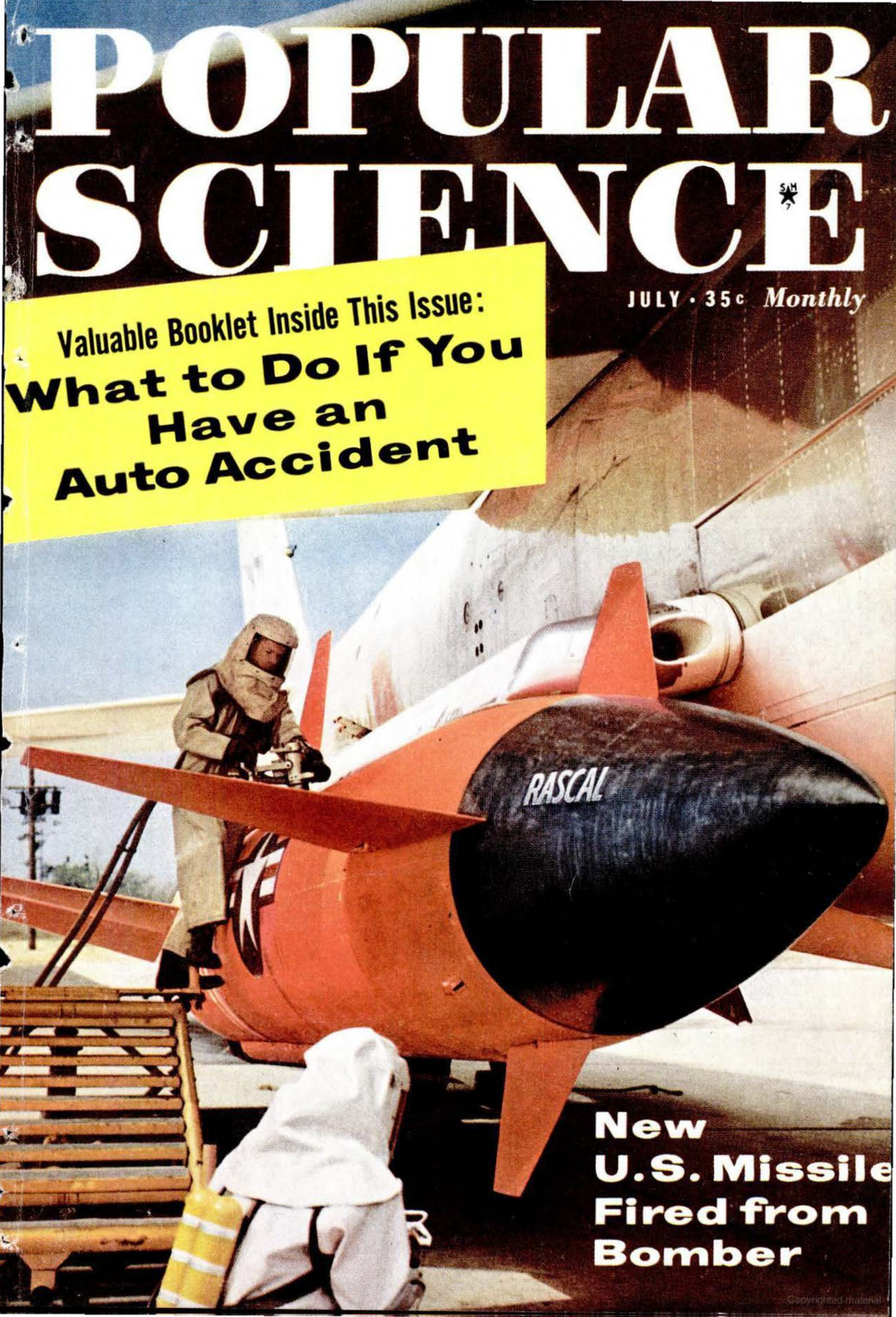

JULY • 35c Monthly

Valuable Booklet Inside This Issue:
**What to Do If You
Have an
Auto Accident**



**New
U.S. Missile
Fired from
Bomber**

"I cleaned and waxed our car in 67 minutes

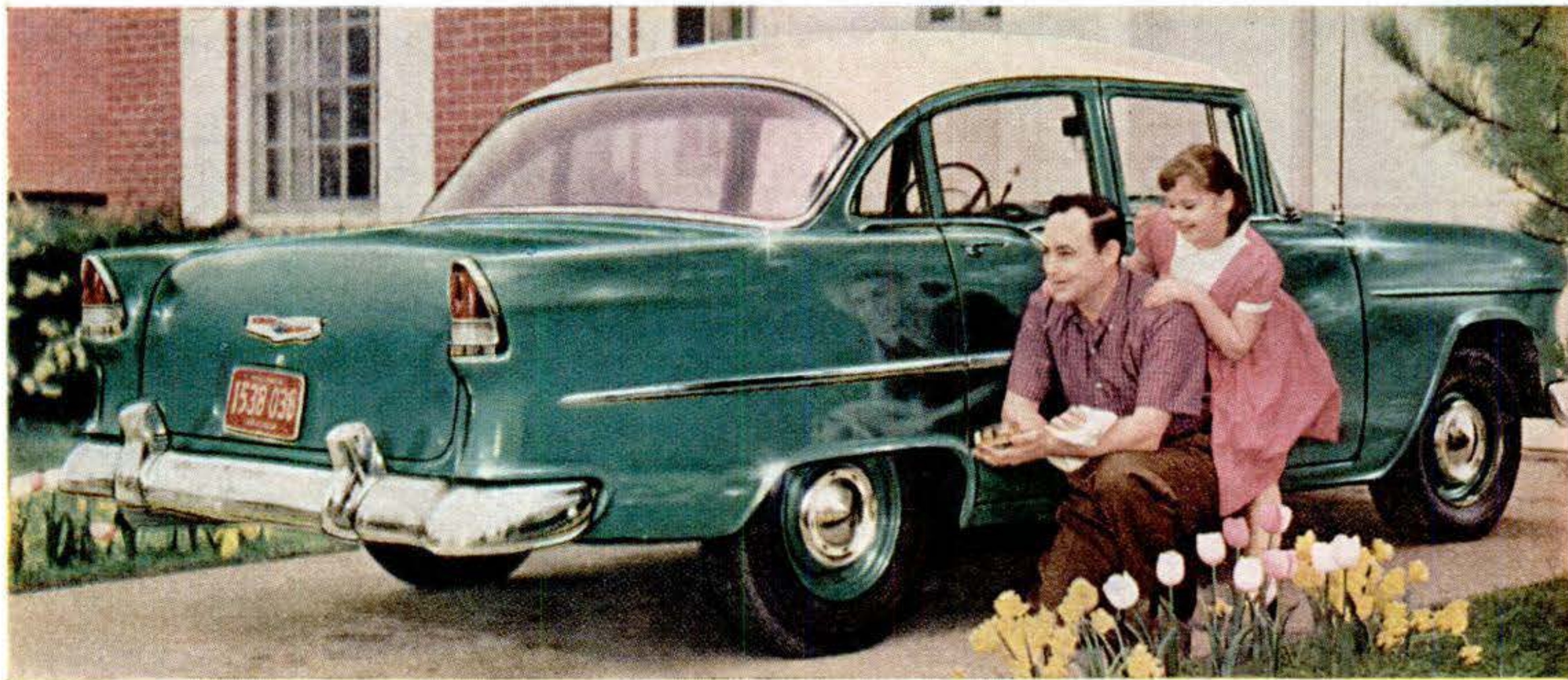

with Du Pont's NEW CAR WAX

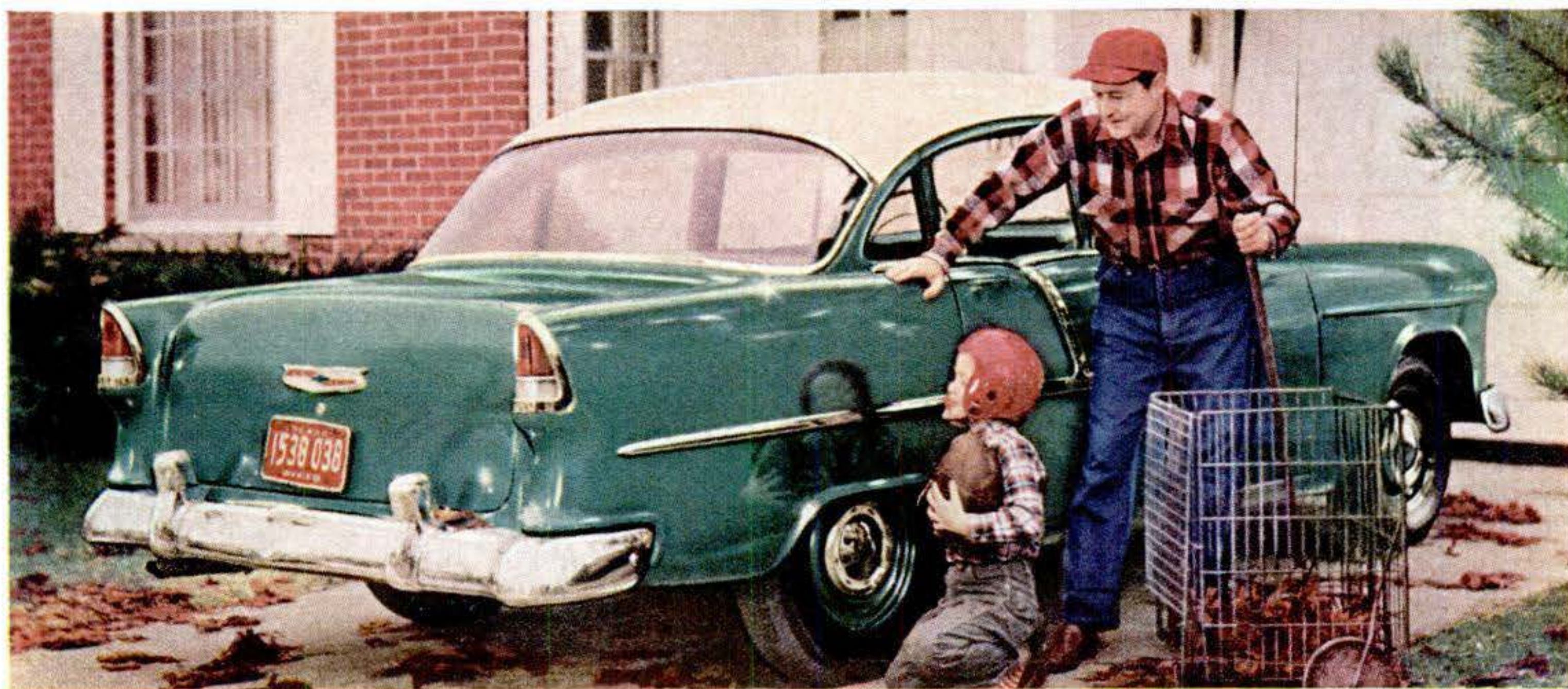

... it still looks great 6 months later"

says Robert MacMorran of Glenview, Ill., after waxing his '55 Chevrolet with Du Pont New Car Wax. Bob found that this new paste wax is as easy to use as liquid polish, because it cleans, waxes and glazes—all in *one easy application*. And it protects with real Carnauba wax, the *toughest wax known*. Proof of protection is the long-lasting gleam. Six months, nine car washings later, the finish shows clear reflections of Bob and his son. Try Du Pont New Car Wax—it makes any good finish look new. At service stations and auto supply stores. Only \$2.00.

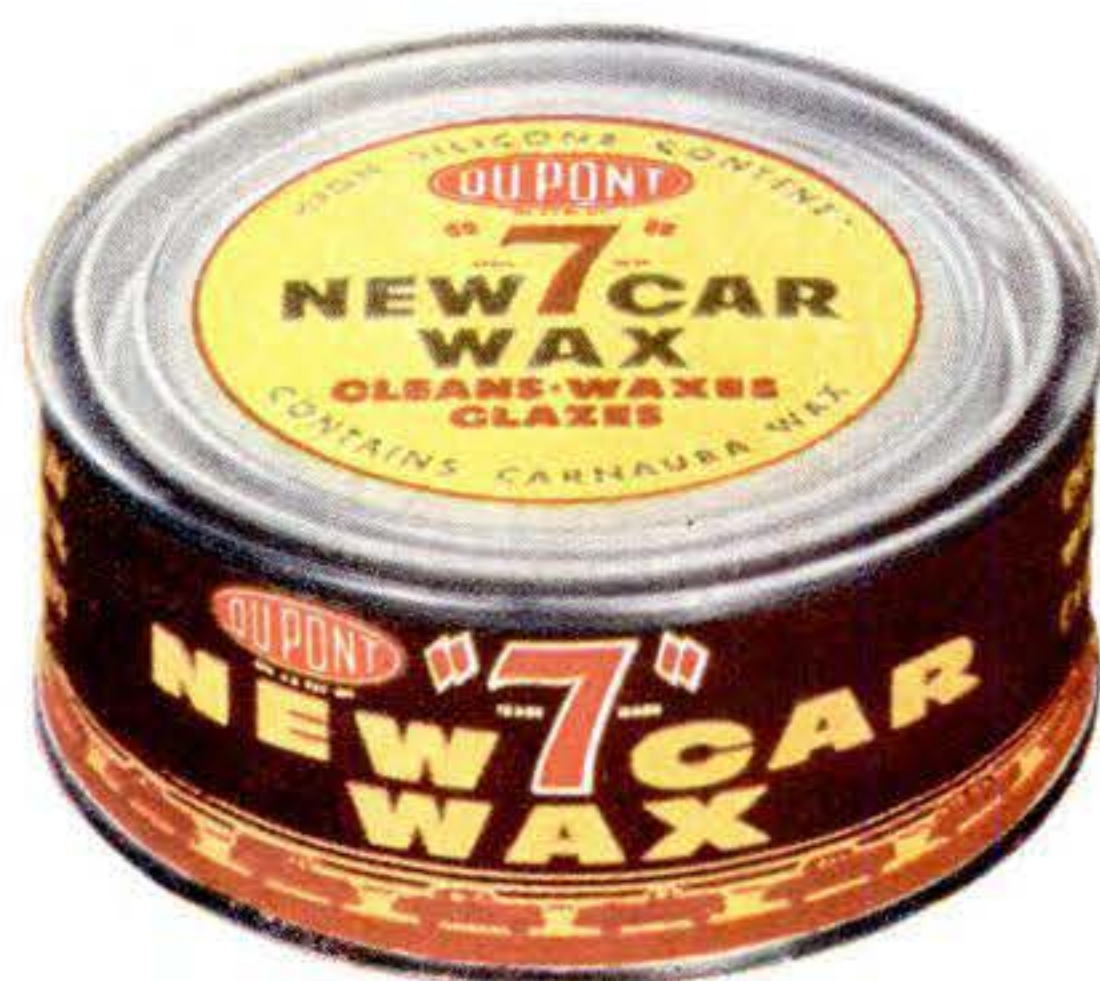

BETTER THINGS FOR BETTER LIVING...THROUGH CHEMISTRY

5-RECORD GLENN MILLER ALBUM FREE

with the first album you buy as a new member of the NEW

RCA VICTOR POPULAR ALBUM CLUB

... if you agree to buy five additional albums from the Club in the next year from at least 100 albums to be made available

This exciting new plan, under the direction of the Book-of-the-Month Club, enables you to have on tap a variety of popular music for family fun and happier parties. Moreover, once and for all, it takes bewilderment out of building such a well-balanced collection.

You pay far less for albums this way than if you buy them haphazardly. For example, the extraordinary introductory offer described above can represent around a 40% saving in your first year of membership.

Thereafter you save almost 33 1/3%. After buying the six albums called for in this offer, you will receive a free 12-inch 33 1/3 R.P.M. album, with a retail price of at least \$3.98, for every two albums purchased from the Club.

A wide choice of RCA VICTOR albums—enough to satisfy every kind of taste—will be described each month. One will be singled out as the album-of-the-month. If you want it, you do nothing—it will come to you automatically. If you prefer one of the many alternates—or nothing at all in any month—you can make your wishes known on a simple form always provided. You pay the nationally advertised price—usually \$3.98, at times \$4.98 (plus a small charge for postage and handling).

NATIONALLY
ADVERTISED
PRICE
\$19.98



AN ALBUM OF FIVE 12-INCH 33 1/3 R. P. M. RECORDS CONTAINING SEVENTY-FIVE DIFFERENT SELECTIONS



These recordings represent the high point as well as the final chapter in Miller's legendary career. Here are 75 selections played by the 50-man, star-studded Air Force Band, including definitive versions of Miller's biggest hits—*In the Mood*, *Tuxedo Junction*, *St. Louis Blues March*, etc. The sound of the original wartime recordings has been enhanced via RCA VICTOR's "New Orthophonic" techniques in order to recapture the glamour and excitement his band once radiated.

BEGIN YOUR MEMBERSHIP WITH ANY OF THESE ALBUMS: WRITE TITLE IN COUPON

- | | |
|--|--|
| WE GET LETTERS . . . Perry Como | MUSIC FOR DINING
Melachrino Strings |
| BELAFONTE Harry Belafonte | BOUQUET OF BLUES
Dinah Shore |
| FRANKIE CARLE'S SWEETHEARTS | SWEET 17 Ames Brothers |
| BRASS & PERCUSSION
Morton Gould | HEART OF HAVANA
Orquesta Aragón |
| JAMAICA Lena Horne | EYES OF LOVE
Hugo Winterhalter |
| STUDENT PRINCE . . Mario Lanza | MOONGLOW Artie Shaw |
| BING WITH A BEAT Bing Crosby | MARJORIE MORNINGSTAR
Original Film Sound Track |
| TOWN HALL CONCERT PLUS
Louis Armstrong | IN A MELLOWTONE Duke Ellington |
| LET'S DANCE with the Three Suns | VICTORY AT SEA
N.B.C. Symphony Orchestra |
| SHORTY ROGERS PLAYS RICHARD RODGERS | PORGY AND BESS
Risë Stevens—Robert Merrill |
| THE FAMILY ALL TOGETHER
Boston Pops | |
| THINKING OF YOU Eddie Fisher | |

THE RCA VICTOR POPULAR ALBUM CLUB

P93-7

c/o Book-of-the-Month Club Inc., 345 Hudson Street, New York 14, N. Y. Please register me as a member of The RCA VICTOR Popular Album Club and send me, free, the five-record album, *Glenn Miller's Army Air Force Band*, with the first Club album I purchase, indicated below. I agree to buy five other albums offered by the Club within the next twelve months, for each of which I will be billed at the nationally advertised price: \$3.98 (at times \$4.98), plus a small charge for postage and handling. Thereafter, I need buy only four such albums in any twelve-month period to maintain membership. I may cancel my membership any time after buying six albums from the Club. After my sixth purchase, if I continue, for every two albums I buy, I may choose a third album free.

(Please print title of purchase album here)

Name _____

Address _____

City _____ Zone _____ State _____

PLEASE NOTE: Send no money. A bill will be sent. Albums can be shipped only to residents of the U. S., its territories and Canada. Albums for Canadian members are made in Canada and shipped duty-free from Ontario.

JULY 1958

Popular Science Monthly

July, 1958

Cover photograph by W. W. Morris

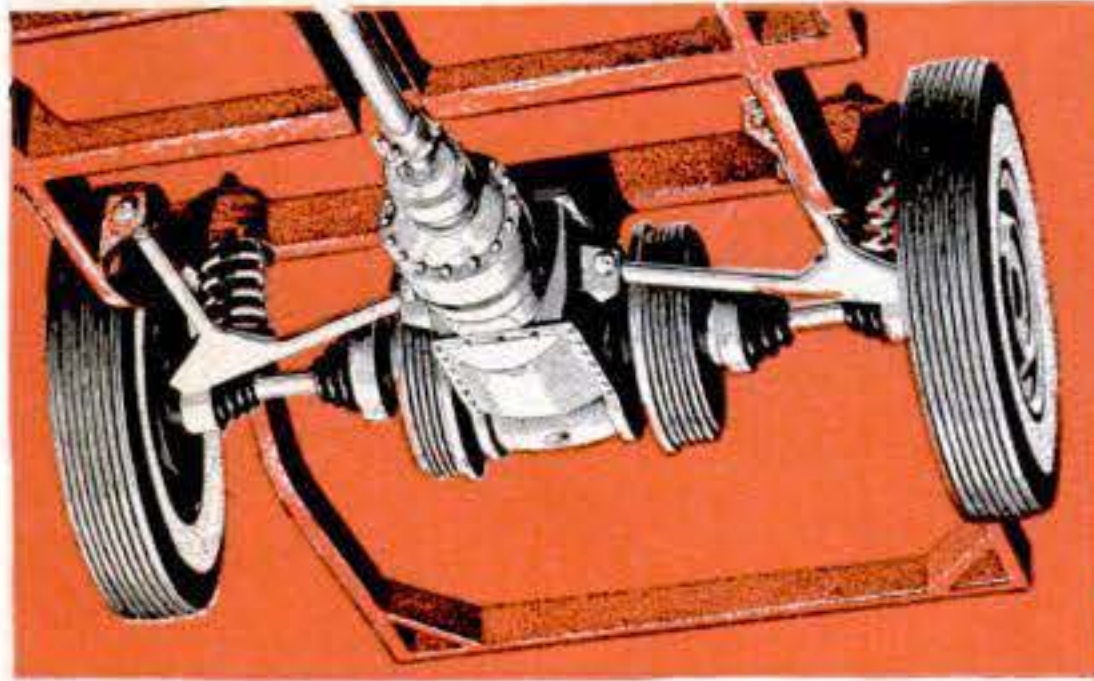

What's Detroit doing about that drive-shaft hump in your car? Here's the inside story of developments that may flatten your floor—and revolutionize the U. S. automobile.

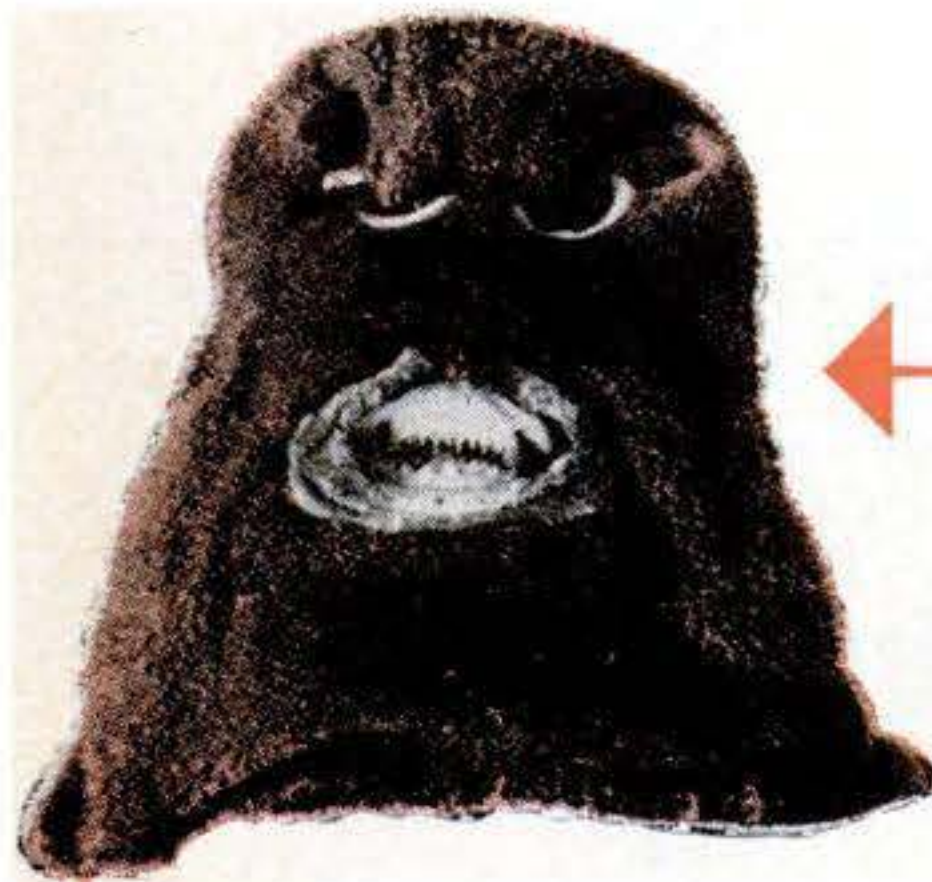

Is this the grin of a man-eater? Meet *Oxynotus*—and some other members of the shark family.

WORLD OF SCIENCE

- [New Missile Is Launched from Bomber · 56](#)
- [The Day They Found Men on the Moon · 61](#)
- [New Ideas on Keeping Cool · 72](#)
- [World's Biggest Sub · 88](#)

CARS AND DRIVING

- [Next Big Change: Flatter Floors · 51](#)
- [First Iron Curtain Car on Sale in U.S. · 65](#)
- [Yes, the New Cars Do Take More Gas · 68](#)
- [How Dangerous Are the Small Cars? · 76](#)
- [Safety Expert Looks at Turnpikes · 83](#)
- Complete Tear-Out Booklet:*
 - [If You Have an Auto Accident · 147](#)

SPECIAL FEATURES

- [When Road Builders Want Your Home · 79](#)
- [What If You Meet a Shark? · 109](#)
- [6 Tips for Small-Boat Skippers · 177](#)

PICTURE NEWS

- [Steel Colossus for A-Power Plant · 92](#)
- [Camera Takes Cone-Shaped Photo · 98](#)
- [Classroom to Schoolyard to Water · 101](#)
- [Dummy Polaris Wears Life Jacket · 102](#)
- [Roll-on Ramp Loads Air Giant Fast · 104](#)
- [Navy Shows Gun-in-a-Pod · 108](#)

Editor: HOWARD ALLAWAY

Managing Editor
FRANK ROWSOME JR.

Assistant Managing Editors
Charles M. Garvey
Kendall W. Goodwyn
Robert P. Stevenson

Senior Editors
Devon Francis
Martin Mann
Everett H. Ortner
Harry Walton

Technical Editor
Hubert Luckett

West Coast Editor
Wesley S. Griswold

Associate Editors

Erik H. Arctander
Alden P. Armagnac
Henry B. Comstock
Frank Dorr
Sheldon M. Gallagher
Herbert O. Johansen
Herbert R. Pfister
Ruth Westphal
Richard A. Yahraes

Editorial Assistants

Rosa Lee Beeland (Chief)
Anna Dallas, Bebe Lipson,
Roberta Marks
Georgette Sparks

Art Director

HOWARD C. JENSEN

Art Editors

Herbert Anthony
Reginald A. Hawley
Harry Samuels

Art Associates

Eric A. Karminski Jr.
Henry W. Kazmirowski
Richard J. Meyer
Dana B. Rasmussen

Photography

W. W. Morris (Chief)
Robert D. Borst
Orlando Guerra

CONSUMER NEWS

Buyer's Guide to '58 Window Fans · 135

What's New · 139

In Tools · For the Car

For the Home Handyman

New Carry-Along Spray Compressor · 142

Big Bargains in Two-Eyed Cameras · 144

HOME AND SHOP

How to Drill Big Holes · 116

How Should Your New House Face? · 121

Home Owner's Repair Section · 125

Know-How File: Cutting Glass

Fix-It File: Doorbells

Materials File: Plastic Tile

TV's Big Troublemaker Circuit · 173

Short Cuts and Tips · 183

AUTO UPKEEP

5 Tip-Offs to a Good Body Job · 159

Washing the Inside of a Car · 163

Hints from the Model Garage · 166

Gus Faces a Low-Down Charge · 168

EVERY MONTH

PS Readers Talk Back · 4

The Month in Science · 11

Keeping the Home Shipshape · 14

You Ought to Know · 17

I'd Like to See Them Make · 20

New Ideas from the Inventors · 113

Wordless Workshop · 180

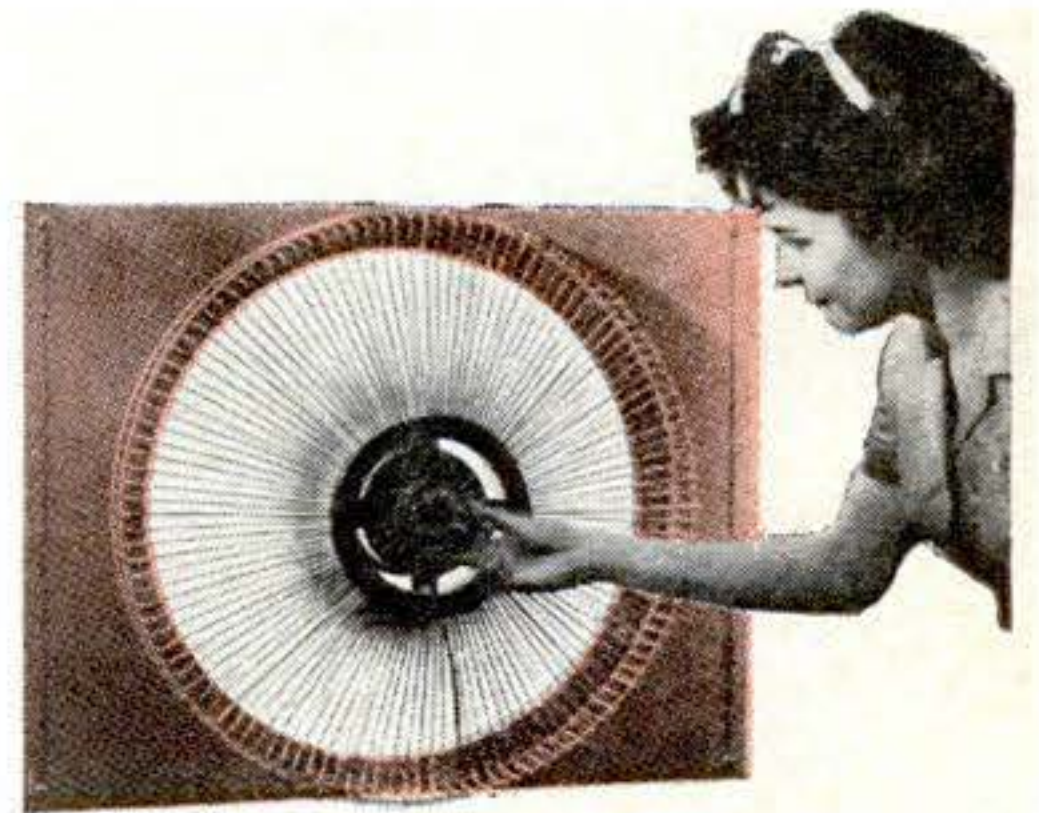

Install a breeze in your window! Here's everything you should know about the new fans. Plus specs.



Clean-up tips and pictures show you how to get that new-car look inside your car as well as outside.

Publisher
RALPH H. FLYNN

Advertising Manager
LEE P. ADAMS

Circulation Director
EUGENE WATSON

EDITORIAL OFFICES:
353 Fourth Ave., New York 10, N.Y.

ADVERTISING OFFICES:
NEW YORK—353 Fourth Ave.
CHICAGO—360 North Michigan Ave.
DETROIT—820 Book Bldg.
SAN FRANCISCO—114 Sansome St.
CLEVELAND—636 B. F. Keith Bldg.
LOS ANGELES—711 South Vermont.
PORTLAND, ORE.—520 S.W. Sixth Ave.

SUBSCRIPTION SERVICE:
Address all subscriptions and correspondence concerning them to: Popular Science Subscription Department, 353 Fourth Ave., New York 10, N. Y. Allow four weeks' notice for change of address. Please give both old and new addresses, including zone numbers. Published monthly at 353

Fourth Avenue, New York 10, N. Y., by Popular Science Publishing Co., Inc., Godfrey Hammond, Chairman of the Board; Ralph H. Flynn, President and Treasurer; Franklin E. Parker Jr., Secretary; Eugene Watson, Vice-President. Second-class mail privileges authorized at New York, N. Y., and Dayton, Ohio. Entered as second-class matter at the Post Office Department, Canada. Printed in U.S.A. Copyright, 1958, by Popular Science Publishing Co., Inc. All rights reserved in the United States, Great Britain, and in all the countries participating in the International Copyright Convention and Pan-American Copyright Convention. Single copy 35¢. Subscriptions to United States, its possessions, and Canada, 1 year \$3.40 (2 years \$6.00, 3 years \$8.00). Elsewhere, 1 year \$6.00 (2 years \$11.00, 3 years \$16.00).

PS Readers

TALK BACK

Questions and Answers

ASK yourself what answer the tester wants, then give it to him, you advise job hunters ["How to Boost Your Score on Any Test," May]. Last June my nephew actually tried this.

An employment agency gave him a "personality test" for a job as clerk in a big insurance firm. Then two days later



someone else at the agency handed him the same test to see if he could run a local branch of a travel bureau.

Three of the questions went something like this:

1. Do you feel most at ease when (a) following a good leader or (b) leading others?

2. In which of these two groups does a hobby appeal to you most? (a) Seeing good movies and plays; reading; swimming; or (b) working in an amateur theatrical group; dancing; boat-racing.

3. If a supervisor gave instructions that you suspected would not work, would you (a) tell him so and propose another way, or (b) bear in mind his longer experience and give his way a try?

The boy answered the office-clerk application with 1-a, 2-a, 3-b. For the job of managing the travel office, he reversed himself: 1-b, 2-b, 3-a.

That's right—he got interviewed by both employers. As it turned out, he didn't take either job—meanwhile word came that he had won a scholarship to law school.

J. A. JOHNSON, Chicago.

Astrophysicist Praises PS Article

ALDEN P. ARMAGNAC'S article, "What We're Learning from the Satellites" [May], is very deftly put together, accurate (so far as our optical competence

can judge), and refreshingly clear. Would that there were more such.

JOHN WHITE

Astrophysical Observatory
Smithsonian Institution
Cambridge, Mass.

Ball Teams Vs. Scientists

IT IS encouraging to know that some Americans are interested in achieving a higher standard of education ["Russian Schools Can Teach Us a Lesson," Mar.]. I believe that Admiral Rickover is on the right track.

Last fall, I left a Canadian high school to continue my studies in Switzerland. There is absolutely no comparison between the two systems in quality of text books, courses, teachers and teaching methods. About 40 percent of the time in my previous school was taken up by extracurricular activities. Now I must catch up on lost academic time.

Large gymnasiums and other facilities serving non-educational functions are

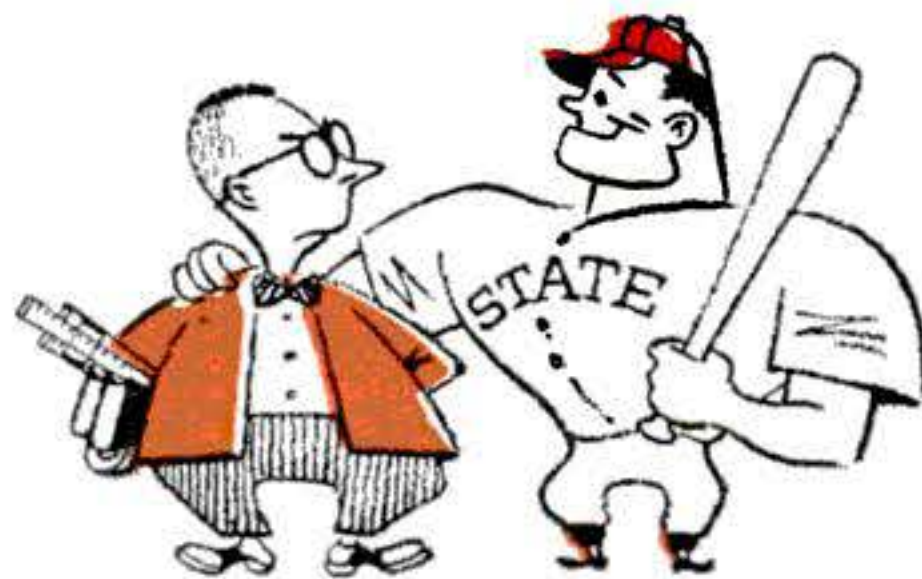

fine, but are schools built to produce a ball team or scientists and leaders?

ARTHUR BRAND, Zurich, Switzerland.

Lost Letter Brings Letters

A SINGLE "m" missing in an April article ["New Radio Steals Its Power from the Air"] has brought us many inquiries. In the parts list, the trimmer condensers are listed as 180 mfd. This, of course, should read 180 mmfd. A published correction might relieve our writer's cramp.

JOHN SMALL

Telepower, Silver Spring, Md.

... I built your telepower receiver and it worked very well. But after some ex-

"HOW A 'CRAZY RUMOR' GOT ME PROMOTED!"



What I overheard one morning shook me right out of a rut!

"Company's getting ready to cut back . . . bound to be layoffs," I heard them say. "Just another crazy rumor," I told myself.

Just the same, I took quick stock of myself that night. Came up with four good reasons why the company would keep me on:

- Three years' experience*
- Getting along with foreman*
- Turning out acceptable work*
- Prompt and dependable*

And four just-as-good reasons why they might let me go:

- Making no real headway*
- Others better qualified*
- Still rated "semi-skilled"*
- Needs special training*

I wasn't in trouble. But I sure wasn't "in solid" like I should be. That's when I made up my mind to enroll for training with I.C.S.

I picked I.C.S. because it's the oldest and largest with 257 courses. The training is quick and thorough. It's recognized by my company and accredited by the National Home Study Council. You study in your spare time and get personalized, practical instruction—know-how you can apply next day on the job.

That was a year ago. There have been two layoffs since then. While some of the others were just hanging on or being released, I was moving up. My I.C.S. training started something. Not only did it get me promoted (with a fat pay hike), but it put me in line for real advancement.

Don't wait for a "crazy rumor" to set you straight. Take out your "job insurance" right now. Mail the coupon and get full, free details on how I.C.S. has helped thousands, how it can help you. No obligation—and you get three valuable books *free!* (1) How to Succeed; (2) Catalog of opportunities in the field of your choice; (3) Sample lesson (math).

For Real Job Security—Get an I. C. S. Diploma! I. C. S., Scranton 15, Penna. Accredited Member, National Home Study Council

INTERNATIONAL CORRESPONDENCE SCHOOLS



BOX 73314G, SCRANTON 15, PENNA.

(Partial list of 257 courses)

Without cost or obligation, send me "HOW to SUCCEED" and the opportunity booklet about the field BEFORE which I have marked X (plus sample lesson):

- | | | | | |
|--|--|--|--|---|
| <p>ARCHITECTURE and BUILDING CONSTRUCTION</p> <ul style="list-style-type: none"> <input type="checkbox"/> Air Conditioning <input type="checkbox"/> Architecture <input type="checkbox"/> Arch. Drawing and Designing <input type="checkbox"/> Building Contractor <input type="checkbox"/> Building Estimator <input type="checkbox"/> Carpentry and Millwork <input type="checkbox"/> Carpenter Foreman <input type="checkbox"/> Heating <input type="checkbox"/> Interior Decoration <input type="checkbox"/> Painting Contractor <input type="checkbox"/> Plumbing <input type="checkbox"/> Reading Arch. Blueprints <p>ART</p> <ul style="list-style-type: none"> <input type="checkbox"/> Commercial Art <input type="checkbox"/> Magazine & Book Illus. <input type="checkbox"/> Show Card and Sign Lettering <input type="checkbox"/> Sketching and Painting <p>AUTOMOTIVE</p> <ul style="list-style-type: none"> <input type="checkbox"/> Automobiles <input type="checkbox"/> Auto Body Rebuilding and Refinishing <input type="checkbox"/> Auto Engine Tuneup <input type="checkbox"/> Auto Technician | <p>AVIATION</p> <ul style="list-style-type: none"> <input type="checkbox"/> Aero-Engineering Technology <input type="checkbox"/> Aircraft & Engine Mechanic <p>BUSINESS</p> <ul style="list-style-type: none"> <input type="checkbox"/> Accounting <input type="checkbox"/> Advertising <input type="checkbox"/> Business Administration <input type="checkbox"/> Business Management <input type="checkbox"/> Cost Accounting <input type="checkbox"/> Creative Salesmanship <input type="checkbox"/> Managing a Small Business <input type="checkbox"/> Professional Secretary <input type="checkbox"/> Public Accounting <input type="checkbox"/> Purchasing Agent <input type="checkbox"/> Salesmanship <input type="checkbox"/> Salesmanship and Management <input type="checkbox"/> Traffic Management <p>CHEMICAL</p> <ul style="list-style-type: none"> <input type="checkbox"/> Analytical Chemistry <input type="checkbox"/> Chemical Engineering <input type="checkbox"/> Chem. Lab. Technician <input type="checkbox"/> Elements of Nuclear Energy <input type="checkbox"/> General Chemistry <input type="checkbox"/> Natural Gas Prod. and Trans. <input type="checkbox"/> Petroleum Prod. and Engr. <input type="checkbox"/> Professional Engineer (Chem) <input type="checkbox"/> Pulp and Paper Making | <p>CIVIL ENGINEERING</p> <ul style="list-style-type: none"> <input type="checkbox"/> Civil Engineering <input type="checkbox"/> Construction Engineering <input type="checkbox"/> Highway Engineering <input type="checkbox"/> Professional Engineer (Civil) <input type="checkbox"/> Reading Struc. Blueprints <input type="checkbox"/> Structural Engineering <input type="checkbox"/> Surveying and Mapping <p>DRAFTING</p> <ul style="list-style-type: none"> <input type="checkbox"/> Aircraft Drafting <input type="checkbox"/> Architectural Drafting <input type="checkbox"/> Drafting Machine Design <input type="checkbox"/> Electrical Drafting <input type="checkbox"/> Mechanical Drafting <input type="checkbox"/> Sheet Metal Drafting <input type="checkbox"/> Structural Drafting <p>ELECTRICAL</p> <ul style="list-style-type: none"> <input type="checkbox"/> Electrical Engineering <input type="checkbox"/> Elec. Engr. Technician <input type="checkbox"/> Elec. Light and Power <input type="checkbox"/> Practical Electrician <input type="checkbox"/> Practical Lineman <input type="checkbox"/> Professional Engineer (Elec) <p>HIGH SCHOOL</p> <ul style="list-style-type: none"> <input type="checkbox"/> High School Diploma | <ul style="list-style-type: none"> <input type="checkbox"/> Good English <input type="checkbox"/> High School Mathematics <input type="checkbox"/> Short Story Writing <p>LEADERSHIP</p> <ul style="list-style-type: none"> <input type="checkbox"/> Industrial Foremanship <input type="checkbox"/> Industrial Supervision <input type="checkbox"/> Personnel-Labor Relations <input type="checkbox"/> Supervision <p>MECHANICAL and SHOP</p> <ul style="list-style-type: none"> <input type="checkbox"/> Diesel Engines <input type="checkbox"/> Gas-Elec. Welding <input type="checkbox"/> Industrial Engineering <input type="checkbox"/> Industrial Instrumentation <input type="checkbox"/> Industrial Metallurgy <input type="checkbox"/> Industrial Safety <input type="checkbox"/> Machine Design <input type="checkbox"/> Machine Shop Practice <input type="checkbox"/> Mechanical Engineering <input type="checkbox"/> Professional Engineer (Mech) <input type="checkbox"/> Quality Control <input type="checkbox"/> Reading Shop Blueprints <input type="checkbox"/> Refrigeration and Air Conditioning <input type="checkbox"/> Tool Design <input type="checkbox"/> Tool Making <p>RADIO, TELEVISION</p> <ul style="list-style-type: none"> <input type="checkbox"/> General Electronics Tech. | <ul style="list-style-type: none"> <input type="checkbox"/> Industrial Electronics <input type="checkbox"/> Practical Radio-TV Eng'r'g <input type="checkbox"/> Practical Telephony <input type="checkbox"/> Radio-TV Servicing <p>RAILROAD</p> <ul style="list-style-type: none"> <input type="checkbox"/> Car Inspector and Air Brake <input type="checkbox"/> Diesel Electrician <input type="checkbox"/> Diesel Engr. and Fireman <input type="checkbox"/> Diesel Locomotive <p>STEAM and DIESEL POWER</p> <ul style="list-style-type: none"> <input type="checkbox"/> Combustion Engineering <input type="checkbox"/> Power Plant Engineer <input type="checkbox"/> Stationary Diesel Engr. <input type="checkbox"/> Stationary Fireman <p>TEXTILE</p> <ul style="list-style-type: none"> <input type="checkbox"/> Carding and Spinning <input type="checkbox"/> Cotton Manufacture <input type="checkbox"/> Cotton Warping and Weaving <input type="checkbox"/> Loom Fixing Technician <input type="checkbox"/> Textile Designing <input type="checkbox"/> Textile Finishing & Dyeing <input type="checkbox"/> Throwing <input type="checkbox"/> Warping and Weaving <input type="checkbox"/> Worsted Manufacturing |
|--|--|--|--|---|

Name _____ Age _____ Home Address _____
 City _____ Zone _____ State _____ Working Hours _____ A.M. to P.M. _____
 Occupation _____

Canadian residents send coupon to International Correspondence Schools, Canadian, Ltd., Montreal, Canada. . . . Special tuition rates to members of the U. S. Armed Forces.

NO BUSTED KNUCKLES



NEW!

PROTO'S



ADJUSTABLE WRENCHES
PAT. PEND.

GOLDEN KNURL HOLDS EXACT JAW OPENINGS AUTOMATICALLY!

NO BUTTONS . . . NO LEVERS . . . NO GADGETS

Save your hands with Proto's Clic-Stops . . . adjustable wrenches with jaws that won't work loose or change adjustment . . . even when dropped or knocked against work. The Clic-Stop saves hands . . . and readjusting time . . . let's you put in more labor.

Meets Federal Specifications: GGG-W-631A, Type 1

Available in FIVE popular sizes*

704L 706L 708L 710L 712L
4", 6", 8", 10", 12"

*Soon Available

716L 720L
16", 20"

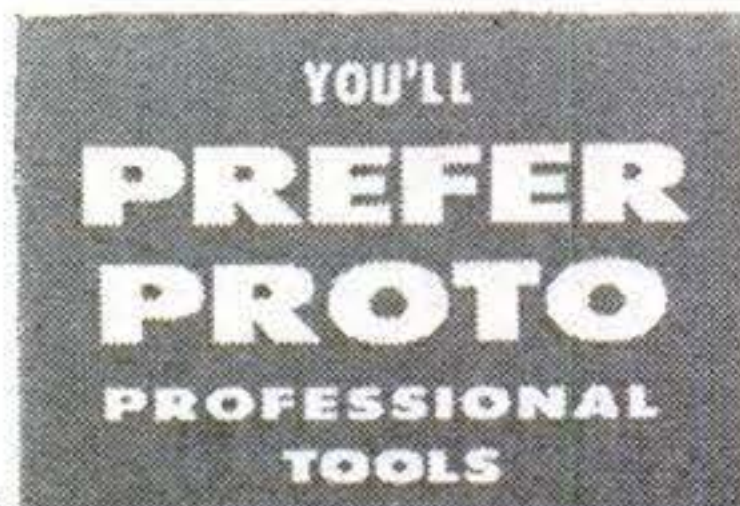

2209 Santa Fe Ave.
Los Angeles 54, Calif.

PENDLETON
DIVISION OF TOOL INDUSTRIES
INC.

perimenting, I think I have come up with a circuit that works equally well and is less expensive to build. As shown on the

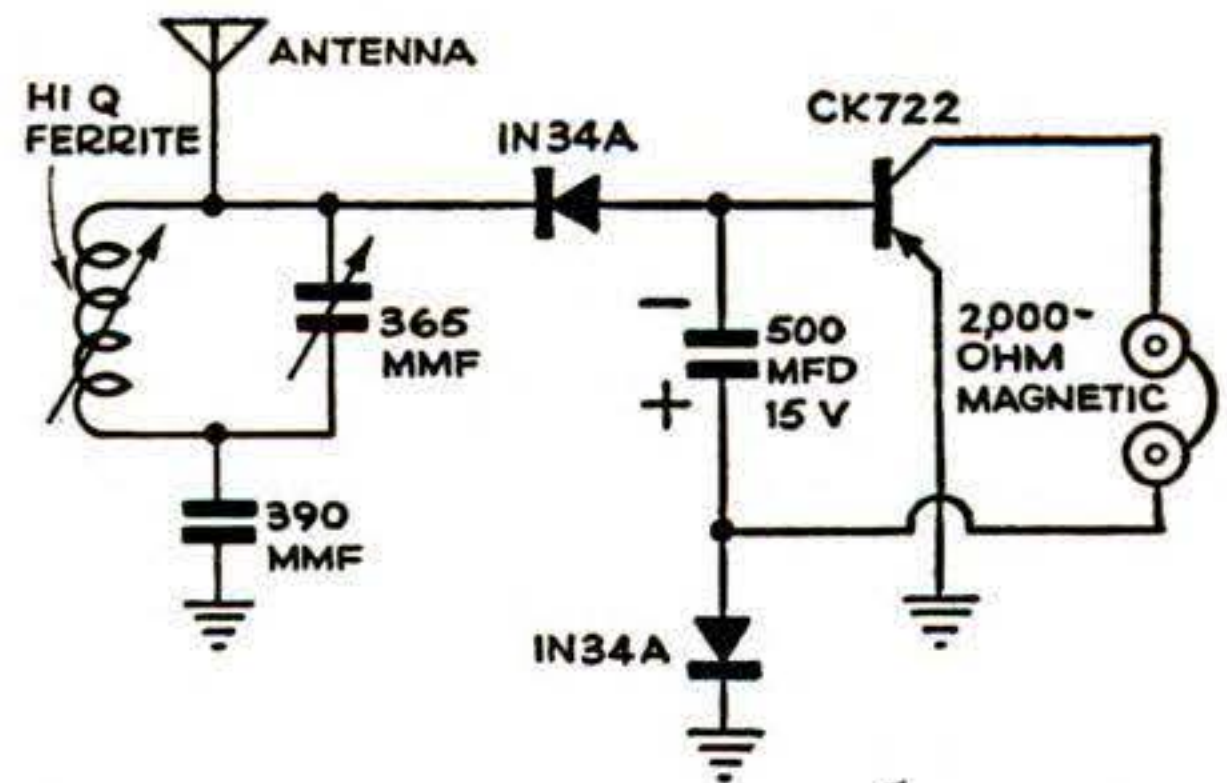

schematic, I used a Ck 722 instead of the Ck 721 transistor you specified.

E. F. SCHMIDT, Springfield, Mo.

Here's a field that's wide open for kitchen-table experimenters. Have any other readers done anything interesting with telepower?

Small-Car Owners Speak Up

IN YOUR report on the "8 Best-Selling Small Cars" [Apr.], you say that the Renault Dauphine averages 28.2 m.p.g. in stop-and-go traffic; 30 m.p.g. on the parkways at a steady 50 m.p.h. I am the proud owner of a 1957 Dauphine and find it impossible to get less than 32 m.p.g. in city traffic, 38 on the road.

ALAN CHAIKIN, W. Hempstead, N.Y.

. . . An owner of a Renault Dauphine, I take exception to your gas-mileage report. I note that the Volkswagen specs indicate a higher gas mileage. I checked these with a VW owner, and we are of the opinion that the two might have been accidentally interchanged.

Your other findings compare pretty well with our own. I, too, wish the Dauphine had a little more "poop" in the engine department. But I wouldn't trade mine for an oversize Detroit barge with horsepower I don't need.

G. R. SCHNEIDERMAN, Los Angeles.

Our gasoline-mileage tests on the Volkswagen and Dauphine were run twice and averaged out. Results were substantially the same on each test. However, a difference in tune of the two cars could have affected our gas-mileage comparisons.

Heart Throbs Cure Head Throbs

I'D LIKE to point out that many attacks of migraine are much more severe

Satisfied with my PRESENT PAYCHECK? **NOT ME!!**



TODAY, you are probably earning enough to get by—enough to provide your family with life's necessities, and perhaps you are depositing a few extra dollars in the bank.

BUT are you content with just earning a living wage? Do you say "Someday I'll really get a break and go right on to the top." **THAT'S WISFUL THINKING!**

You know that the "breaks" go to the man or woman who is *prepared* to take advantage of them—to the person who can fill the better job and who is worth more money. He makes the "breaks" instead of waiting for them.

DO YOU QUESTION YOUR OWN ABILITY?

There is a field of business which has never been overcrowded—it's the **ACCOUNTING FIELD**. And the demand for skilled accountants—men and women who really know their business—is increasing. State and Federal legislation requires much more efficient accounting from business. Corporations are in constant need of expert counsel in matters relating to Auditing, Cost Accounting, Business Law, and Federal Income Tax. Men who prove their qualifications in this important branch of business are promoted to responsible executive positions—given an opportunity to earn real salaries. The range is \$5,000 to \$10,000 a year—even to higher income figures.

WHY BE SATISFIED WITH YOUR PRESENT JOB?

Why accept mediocre pay when right in your own home you can acquire the necessary training to advance rapidly in the profitable, growing field of Accounting.

Under the LaSalle Problem Method you can acquire a thorough knowledge of Accounting, master its fundamental principles, become expert in the practical application of those

principles—without losing an hour from work or a dollar of pay.

Your training will be under the supervision of organization and management specialists, Attorneys and Certified Public Accountants. Preliminary knowledge of bookkeeping is not necessary. We train you from the ground up—Basic Accounting right on up through the Certified Public Accountant training.

SO RIGHT NOW—TODAY

If you are ambitious—if you are interested in a high-paying career—investigate the opportunities in this profitable field.

FREE SAMPLE LESSON

Decide today to send for LaSalle's Accounting Lesson Number One, also **FREE** book, "Opportunities in Accounting." In it you will find complete information on the opportunities which are open to those qualified, and you will learn how you can prepare yourself for a better job and more money. **NO OBLIGATION. MAIL THE COUPON TODAY.**

ACCREDITED MEMBER, NATIONAL HOME STUDY COUNCIL

FIFTY YEARS OF QUALITY TRAINING

SEND FOR FREE BOOKS

LaSalle Extension University

A Correspondence Institution

Dept. 783H, 417 S. Dearborn St., Chicago 5, Ill.

Please send me, free of all cost or obligation, Free sample lesson, and your illustrated book, "Opportunities in Accounting."

Name.....Age.....

Address.....

City, Zone, State.....

MAIL THE
COUPON
TODAY!

OVER 4,500 CPAs
HAVE BEEN TRAINED
BY THE LA SALLE
PROBLEM METHOD



than described in your February issue ["What Science Knows About Headaches"].

One case I know of had periods of visual blackouts, numbness of hands, loss of speech for an hour at a time, all of which symptoms were not repeated for weeks or months—then hit again.

Several medical men have told me—a victim for many years—that migraine appears to follow interruptions of work schedules and personal relationships, and is sometimes more like a mild form of epilepsy than a mere headache. It often stops after a hearty meal. Another doctor told me that people in love seldom have migraine attacks.

E. T. NESBITT, Quebec, Can.

Gun for Hire?

I've tried curing my dog of chasing cars. So your tips in "What Science Has Done for Your Dog" [May] caught my eye.

You say drive by in a friend's car, and use one of three punitive measures as Fido comes running out to bark and chase. *Jump out and switch him.* I doubt if I could get out of a tight-fitting modern car

fast enough to stop Fido's usually fast retreat. *Throw water on him.* I shy from such exhibitionism as this. *Toss a firecracker at him.* In my state you can't use firecrackers without a license.

I've found a simpler cure. Buy a kid's water pistol. Fill it with diluted house-



hold ammonia. Fire a few squirts in Fido's direction from the moving car. Dogs can't stand the scent of ammonia.

CHARLES GRANT, Larchmont, N.Y.

Short Cut Pleases Pro

KEN MURRAY's idea of using a little felt washer at the bottom of the knockout punch die, or chassis punch ["Short Cuts and Tips," Mar.] to lubricate the screw is a clever one. This should definitely, at all times, keep the screw lubricated for longer wear.

We'd like to use this little hint ourselves, if you don't mind.

GREENLEE TOOL Co., Rockford, Ill.



Petroleum engineer with a tough hair problem. John Doles spends his days on an oil rig off Louisiana's Gulf Coast. He's outdoors a lot, and sun and wind punish his hair.



He licks it with Vitalis. Vitalis gets John's hair in condition for important occasions—like taking his wife out dancing. His hair never looks messy, thanks to greaseless V-7.

New greaseless way to keep your hair neat all day... and prevent dryness

If you like your oil in wells and not on your hair, you'll like Vitalis. It keeps hair in condition . . . prevents dryness.

Your hair never has a greasy look because Vitalis grooms with greaseless V-7. Use Vitalis every morning.

New VITALIS® Hair Tonic with V-7®

ANOTHER FINE PRODUCT OF BRISTOL-MYERS

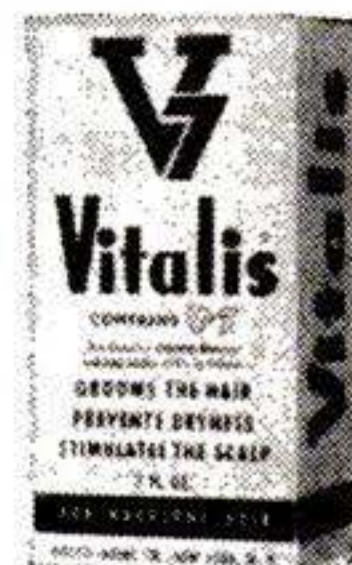

Train at Home for **SUCCESS** in **RADIO-TELEVISION**

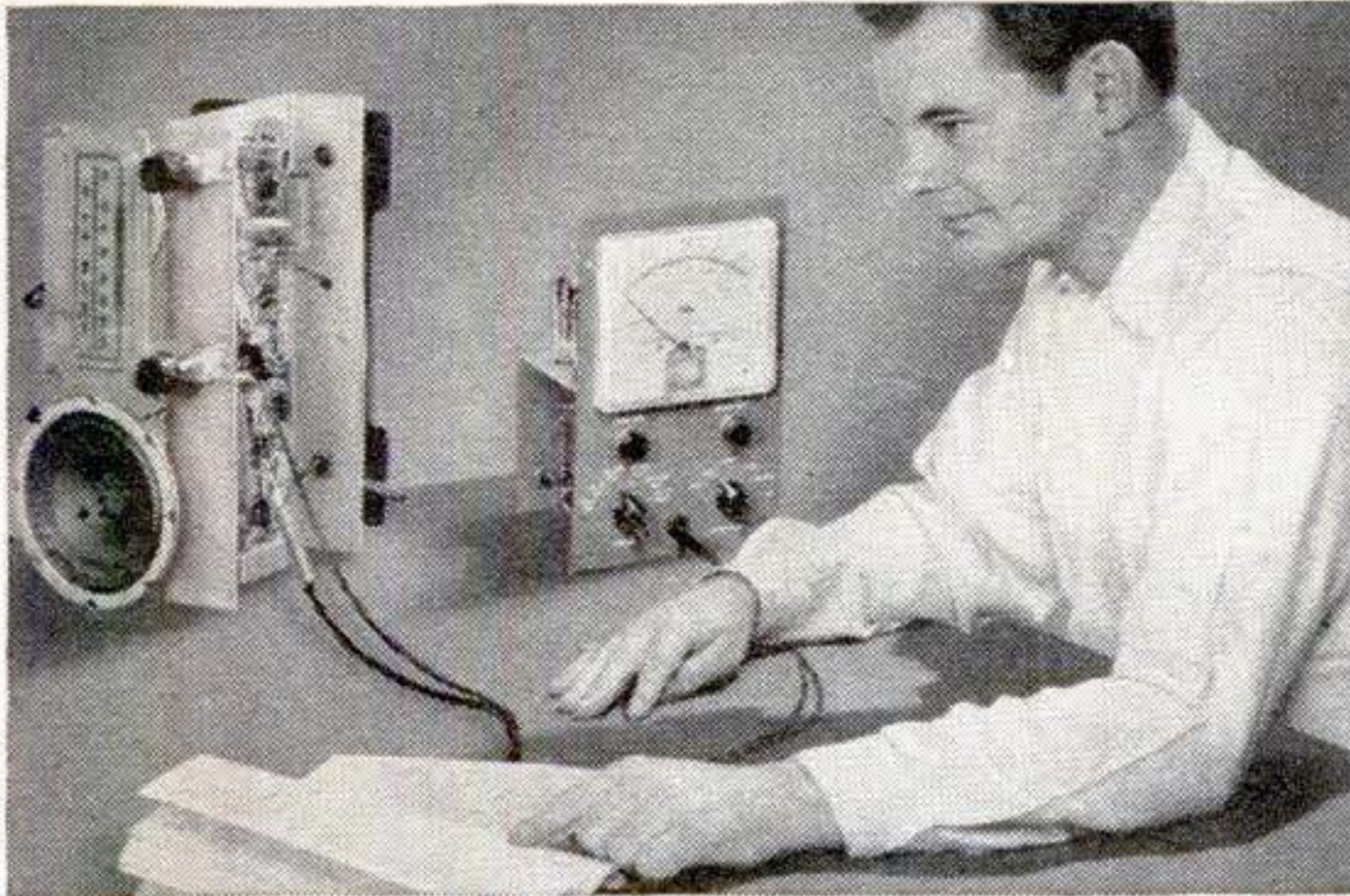

You Learn at Home by Actual Practice

With NRI kits you build actual Radio-Television circuits and testing instrument. Practice locating and fixing Radio-Television troubles. Learn soon to earn extra money.



Good Jobs in Radio-TV Communications

NRI trained men hold good jobs as operators and technicians in Radio and Television broadcasting stations, with Police, Marine and Aviation stations. Interesting work, good pay.



There's Good Pay in Radio-TV Servicing

NRI trained technicians are needed, paid well, to help maintain 150 million home and auto Radios, 38 million TV sets. Color TV, Hi-Fi adding opportunities. Excellent field for spare time earning.

Join the thousands N.R.I. has trained for Successful Careers in Radio-TV

Get the benefit of NRI's 40 years experience training men for success in this field. Get personal attention of experienced instructors. Also get practice with Radio-TV equipment—learn by *doing*—with kits supplied as part of your course. Courses are easy to learn. Most successful NRI men start without any knowledge of Radio, many without a high school education.



J. E. Smith
Founder

Find Out What Radio-TV Offers You

As trained Radio-TV Technician, you are prepared to supply much needed services. The technician is a respected and appreciated member of his community. Get Sample Lesson FREE. See how practical NRI has made learning at home. Mail the coupon. You also get 64-page Catalog telling about NRI, the lessons, equipment supplied, instruction services.

N.R.I. TRAINED THESE MEN FOR SUCCESS



"I am a police captain and have a good spare time Radio-Television service business. Just opened new shop." C. W. LEWIS, Pensacola, Florida.



"Received my License and worked on ships. Now Chief Engineer Station WAPA. Grateful to N.R.I." R. D. ARNOLD, Rumford, Rhode Island.



"Enrolled while meat market manager. Got serviceman job. In a year my pay increased 50%." C. CARTER, San Bernardino, California.



"Have a Radar job. Also do spare time Radio-Television servicing. Have my own amateur Radio Station." F. ZAWAKE, Scranton, Pennsylvania.

Added Income Soon—\$10, \$15 a Week in Your Spare Time

Soon after enrolling, many NRI students earn \$10, \$15 a week extra fixing sets in spare time. Vacuum Tube Voltmeter you build with parts we send helps you locate and fix troubles. Special lessons show you how. Many students use spare time earnings to pay for their training, and provide capital to start their own businesses when they get their National Radio Institute Diploma.

Color TV Making More Jobs

Radio-Television is an industry noted for continued and spectacular growth. Number of trained men employed has increased each year. Color TV and Hi-Fi late developments creating need for more technicians. The future is very bright for trained men. Find out how you can get ready at low cost, on easy terms. Send for FREE Sample Lesson and Catalog. Mail coupon today—National Radio Institute, Dept. 8GB, Washington 16, D. C.

VETERANS—Approved under GI Bills

MAIL COUPON TODAY

NATIONAL RADIO INSTITUTE

Dept. 8GB, Washington 16, D. C.

Please send sample lesson of your Radio-Television Training catalog. FREE. (No salesman will call. Please write plainly.)

Name.....Age.....

Address.....

City.....Zone.....State.....

ACCREDITED MEMBER, NATIONAL HOME STUDY COUNCIL

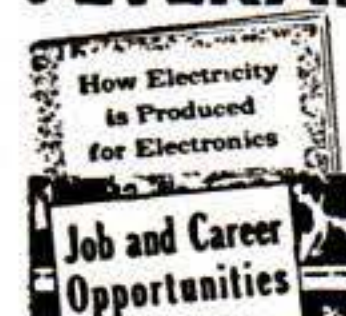

Send for Sample Lesson and Catalog FREE

GET READY FOR THE SPACE ERA! SEE THE SATELLITES . . . THE MOON ROCKETS

AMAZING TELESCOPE BUYS AND OTHER OPTICAL BARGAINS

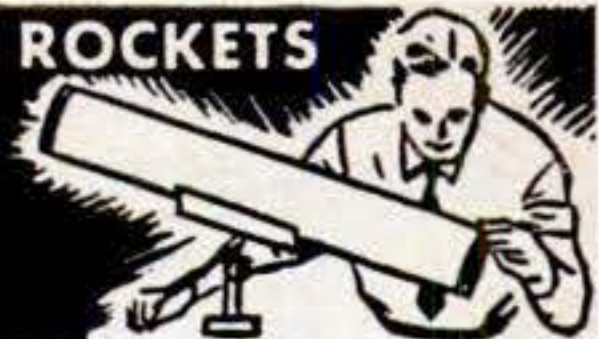

See the Stars, Moon, Planets Close Up!

3" ASTRONOMICAL REFLECTING TELESCOPE

60 to 160 Power—Famous Mt. Palomar Type! An Unusual Buy! Assembled—Ready to use! You'll see the Rings of Saturn, the fascinating planet Mars, huge craters on the Moon, Star Clusters, Moons of Jupiter in detail. Galaxies! Equatorial mount with lock on both axes. Aluminized and over-coated 3" diameter high-speed f/10 mirror. Telescope comes equipped with a 60X eyepiece and a mounted Barlow Lens, giving you 60 to 160 power. Low-cost accessory eyepiece available for power up to 320. An Optical Finder Telescope, always so essential, is also included. Sturdy, hardwood, portable tripod. Valuable STAR CHART and 272-page "Handbook of Heavens."

Stock No. 85,050-N. \$29.50 f.o.b. (Shipping wt. 10 lbs.)

4 1/4" REFLECTING TELESCOPE! Up to 270X!



With this scope you can see everything as above but with greater power plus will split finer stars. Mirror has twice the light gathering power. Mirror guaranteed to give theoretical limit of resolution. Rack and pinion focusing, hardwood tripod, real equatorial mounting—only one adjustment follows stars! Aluminum tube. 6 power finder telescope. 2 standard size eyepieces and mounted Barlow lens give you powers of 40X, 90X, 120X, and 270X. Low-cost accessory eyepiece available for power up to 540. Free handbook and Chart. Shipping weight 25 lbs.

Stock No. 85,006-N \$74.50 f.o.b.

MAKE YOUR OWN ASTRONOMICAL TELESCOPE

4 1/4" MIRROR KIT—Contains ready-to-use 4 1/4" diameter concave, aluminized objective mirror, lenses for 1" focal length eyepiece, and aluminized first surface diagonal mirror.

Order Stock No. 50,074-N. Price \$16.25 postpaid

4 1/4" Mirror only—Stock No. 50,051-N. Price \$15.00 postpaid

We have additional eyepieces, tubes, tripods, in fact everything you need to build telescopes.

New! 2 in 1 Combination! Pocket-Size

50 Power MICROSCOPE and 10 Power TELESCOPE Useful Telescope and Microscope combined in one amazing, precision instrument. Imported! No larger than a fountain pen. Telescope is 10 Power. Microscope magnifies 50 Times Sharp focus at any range. Handy for sports, looking at small objects, just plain snooping.

Send Check or M.O. Satisfaction Guaranteed. Order Stock No. 30,059-N. \$4.50 Pstpd.

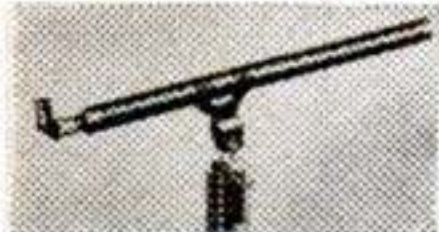

Real 150 Power Astronomical Telescope ONLY \$16.95 Postpaid

A good value at this price though this type & size is not the equal of the Reflecting scopes above. Refractor type! Clear, razor-sharp viewing of stars, planets, craters on moon, etc. 32mm achromatic objective lens! First surface mirror diagonal (ends "stoop" viewing). Removable eyepiece—interchangeable. 50, 75, and 150 power! Tube length 27 1/2" Special attachment clamp for vibrationless viewing. Money back guarantee. Included free: 272-page "Handbook of the Heavens," Star Chart—and 16 page Star Booklet. Stock No. 80,060-N. \$16.95 Postpaid

Order Stock No. 85,059-N 24", used. Price \$39.50 f.o.b. Utah
Order Stock No. 85,060-N 24", new. Price \$59.50 f.o.b. Utah

SALE! TERRIFIC WAR SURPLUS BARGAIN!

AERIAL CAMERA LENSES

Gov't Cost \$1218—Now Low as \$39.50 Used

Made by B & L and E.K.—24" F.L. f/6, in 23" long Lens Cone. Use as long range, Big Bertha Telephoto lens—for Richest field (wide field, low power) telescope, etc. Lenses are 4" dia.—precision 4-element type, Aero Tessar and Aero Ektar (no choice). Easily removed. Diaphragm (f/6 to f/22) is included. Opens approx. 1" to 3 1/2". Lens and cone—wt. 25 lbs. Sturdy carrying trunk—wt. 26 lbs.

Order Stock No. 85,059-N 24", used. Price \$39.50 f.o.b. Utah
Order Stock No. 85,060-N 24", new. Price \$59.50 f.o.b. Utah



BUILD A SOLAR ENERGY FURNACE

A fascinating new field. Build your own Solar Furnace for experimentation—many practical uses. Easy! Inexpensive! Use scrapwood! We furnish instructions. This sun powered furnace will generate terrific heat—2000° to 3000°. Fuses enamel to metal. Sets paper aflame in seconds. Use our Fresnel Lens—14 3/4" diameter . . . f.l. 14".

Stock No. 70-130-N. . . . Fresnel Lens. . . . \$6.00 Pstpd.

STEREO MICROSCOPE



American-Made Instrument at Over 50% Saving. Up to 3" Working Distance—Erect Image—Wide 3-Dimensional Field. Used for inspections, examinations, counting, checking, assembling, dissecting. 2 sets of objectives on rotating turret. Standard pair of wide field 10X Kellner Eyepieces give you 23 power and 40 power. Helical rack and pinion focusing. 10-DAY TRIAL . . . Complete satisfaction or your money back. Order Stock No. 85,056-N. Full price . . . \$99.50 f.o.b. Barrington, N.J.

Low Power Supplementary Lens Attachment for above Stereo—provides 15X down to 6X with clear, extra large 1 1/2" field at 6X. Stock #30,276-N . . . \$7.50

Check, Measure, Inspect with this 6 POWER

POCKET COMPARATOR

(Complete with Leather Case)

MEASURES • Angles • Radii • Circles • Linear—in both decimal inches and millimeters.

Used to check layouts, machining on tools, dies, gauges; to check threads, chamfers, wear on cutting tools, etc.

Stock No. 30,061-N. . . . New Low Price. . . . \$19.50 Pstpd.



HANDY! FAST! ACCURATE!



NEW! STATIC ELECTRICITY GENERATOR

See a thrilling spark display as you set off a miniature bolt of lightning. Absolutely safe and harmless. Stands 14" high. Turn the handle and two 9" plastic discs rotate in opposite directions. Metal collector brushes pick up the static electricity, store it in the Leyden jar type condenser until discharged by the jumping spark. Countless tricks and experiments. 24 page Instruction booklet included. Stock No. 70,070-N. . . . \$10.95 Postpaid

INFRARED SNIPERSCOPE TELESCOPE & PARTS



See in the dark—without being observed. War Surplus Sniperscope M-2. Contains the famous IP25-A Image Tube. Govt. cost about \$1200. Instrument complete, ready to use. Includes Power Pack, infrared light source. Will operate from 6V auto battery. Battery or transformer available.

Stock No. 85,053-N. . . . \$150.00 f.o.b.

Save still more money! Build your own Sniperscope! We will furnish instructions—parts, including: Power Packs, 1P25A image tubes, light units, filters, etc. For details—request FREE Catalog "N."

DIRECT MEASURING POCKET MICROSCOPE

—50 POWER

Fountain pen size, makes direct reading measurements; for checking small parts and dimensions under powerful magnification. Precision, glass etched reticle calibrated for measurements up to 1/10" by .001" divisions.

STOCK NO. 30,225-N. . . . \$7.95 Pstpd.

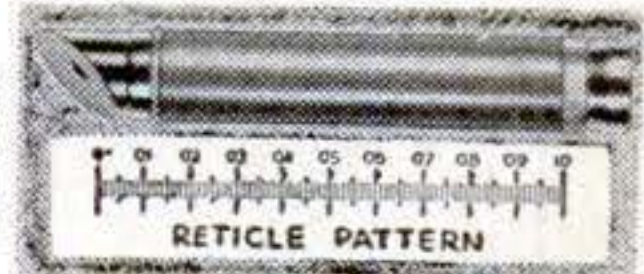

6X Finder Telescope, base fits any diameter tube. Stock No. 50,121-N. . . . \$8.00 postpaid

Mounted Barlow Lens . . . double and triple your telescope's power. Stock No. 30,200-N. . . . \$8.00 postpaid

KELLNER EYEPIECE—Large 50° field—mounted and ready to use. 1 1/4" outside diameter. Stock No. 5223-N. . . . \$7.95 postpaid

MOUNTED HERSHEY WEDGE—40mm x 55 mm—10° angle—mounted with diagonal holder for reflectors for solar observation. Stock No. 30,266-N. . . . \$5.50 postpaid

REFLECTING TELESCOPE EYEPIECE MOUNT—Rack and pinion focusing—takes standard 1 1/4" eyepieces. Stock No. 50,077-N. . . . \$9.95 postpaid

FREE CATALOG-N

Yours for the asking

America's No. 1 source of supply for experimenters, hobbyists. Complete line of Astronomical Telescope parts and assembled Telescope. Also huge selection of lenses, prisms, war surplus optical instruments, parts and accessories. Telescopes, microscopes, satellite scopes, binoculars, infrared sniperscopes, etc.



REQUEST CATALOG-N

ORDER BY STOCK NUMBER . . . SEND CHECK OR MONEY ORDER . . . SATISFACTION GUARANTEED!

EDMUND SCIENTIFIC CO. BARRINGTON, NEW JERSEY

The month in science

.....

Hot atoms are cheaper. Expect to meet—in person—the strange products of the atomic age before long. For the first time, you will come across those wonders of the laboratory, radioactive isotopes, in everyday life, doing old jobs better and making possible some entirely new ones.

Reason: AEC has cut isotope prices like a recession-crazed car dealer. One particularly useful isotope, strontium 90, was tagged at \$500 per curie. Now it's \$5. (A curie is a measure of the amount of radioactivity and represents quite a lot.)

It's not that business is slow with the AEC. Oak Ridge, the main plant, grossed \$2,700,000 on isotopes last year, double the 1954 volume. There are just a lot more isotopes to sell.

Radioactive isotopes are the ashes from atomic furnaces. When the uranium fuel splits, it generates hundreds of kinds of hot atoms, most of which can be made no other way. These ashes must be separated to recover the valuable unburnt fuel remaining (the fuel never burns up completely).

Until now, the isotopes have been separated by a small-scale laboratory setup. Hence the high cost. But the number of atomic furnaces operating is increasing rapidly (121 now, 89 being built, 67 planned). That means a lot of ashes to refine, a lot of isotopes.

A new, bigger ash refinery opens this summer. AEC cut isotope prices on the basis of this greater capacity.

What can you do with isotopes—even at low prices? Radioactive materials are unique. They throw off pieces of themselves—energetic rays that are invisible and silent yet easy to detect or manipulate. Some lose this valuable property in minutes, others can continue it for hundreds of thousands of years.

Ingenious ways of exploiting radioactivity already keep 100 firms in business packaging and distributing hot atoms. Present commercial uses, sure to be stimulated by lower prices, include:

- ▶ Small, lightweight “X-ray” machines, which use hunks of cesium 137 instead of X-ray tubes. Rays from cesium 127 penetrate solid materials and affect photographic film, just like X rays.
- ▶ Luminous signs. Strontium 90 gives off rays that make phosphors glow on instrument dials, road signs, safety markers.
- ▶ Thickness gauges. Counting the rays passing through a solid material gives a sensitive measure of its thickness or density. Cigarette factories already use 3,000 of these little gadgets to make sure you get your smokes firm and fully packed.
- ▶ Batteries. The rays from isotopes can be turned into electricity in a wire by at least five different methods. Big advantage of these atomic batteries is small size and exceptionally long life; big disadvantage is low power.

That's only the beginning. AEC itself suggests one new use (potentially a very large one):

Put some hot atoms inside fluorescent lamp tubes to eliminate

The month in science

starters and transformers. The isotope rays would keep the gas inside the lamp electrically charged, ready to conduct current and shed light when you turned on the switch.

Airplane fuel, absolutely free. Ready for test flights in maybe a year will be a weird kind of very-high-altitude (70 or 80 miles) airplane that seems fantastically close to a perpetual-motion machine. Its fuel: atoms of air. Its engine: an open-ended pipe coated with everlasting chemicals (no moving parts at all).

The trick is the fuel. Ordinary air at the earth's surface contains oxygen in molecular form, each molecule consisting of two oxygen atoms joined together. Up high, however, ultraviolet rays from the sun break up the oxygen molecules, and the thin air contains single oxygen atoms. If you make the separate atoms combine into two-atom molecules, heat is generated.

The engine is a ramjet flying stovepipe, which scoops air in and heats it so that it goes out the back faster than it came in the front. This propels the plane forward.

The new idea is to get the heat from the combining oxygen atoms. A chemical catalyst coating the inside of the chamber would make the oxygen atoms combine, but would not be affected by the reaction.

Technically, all this is possible. Question: Can you use the free fuel efficiently enough to keep a plane aloft? Answer: Maybe.

Up where oxygen atoms live alone, there aren't very many of them. The most energy you could expect from combining atoms in a cubic foot of 85-mile-high air is around .0001 B.T.U. That's not much. To fly, the plane might have to be 1,000 feet or more long and made out of nothing heavier than Reynoldswrap.

Such a craft isn't as useless as it sounds. Running on air, it could fly continuously. Made of aluminum, it would be a good radar reflector, might serve as a relay mirror for TV networks.

First test flight will be made by a small plane. It cannot take off from the ground, but must be launched like a satellite from the nose of a rocket. It will be collapsible, automatically unfolding to the right shape after it is shot out of the rocket nose.

Death rays in space. U.S. satellites have radioed back discovery of an unforeseen barrier to space exploration—deadly radiation that begins 1,000 miles up. University of Iowa scientists exonerate cosmic rays, suspect the culprit is a stream of fast electrons from the sun. Hitting the satellites' metal, they generate X rays—enough to be dangerous to men after three days' exposure.

If the radiation barrier is only a narrow band, it won't stop long-range space ships. They could pass through before serious harm was done. But it means that space platforms orbiting in this region will need the extra complication of heavy shielding.

Walter Dill

THESE MEN ARE GETTING PRACTICAL TRAINING IN **ELECTRICITY**

—ELECTRONICS

On Real:

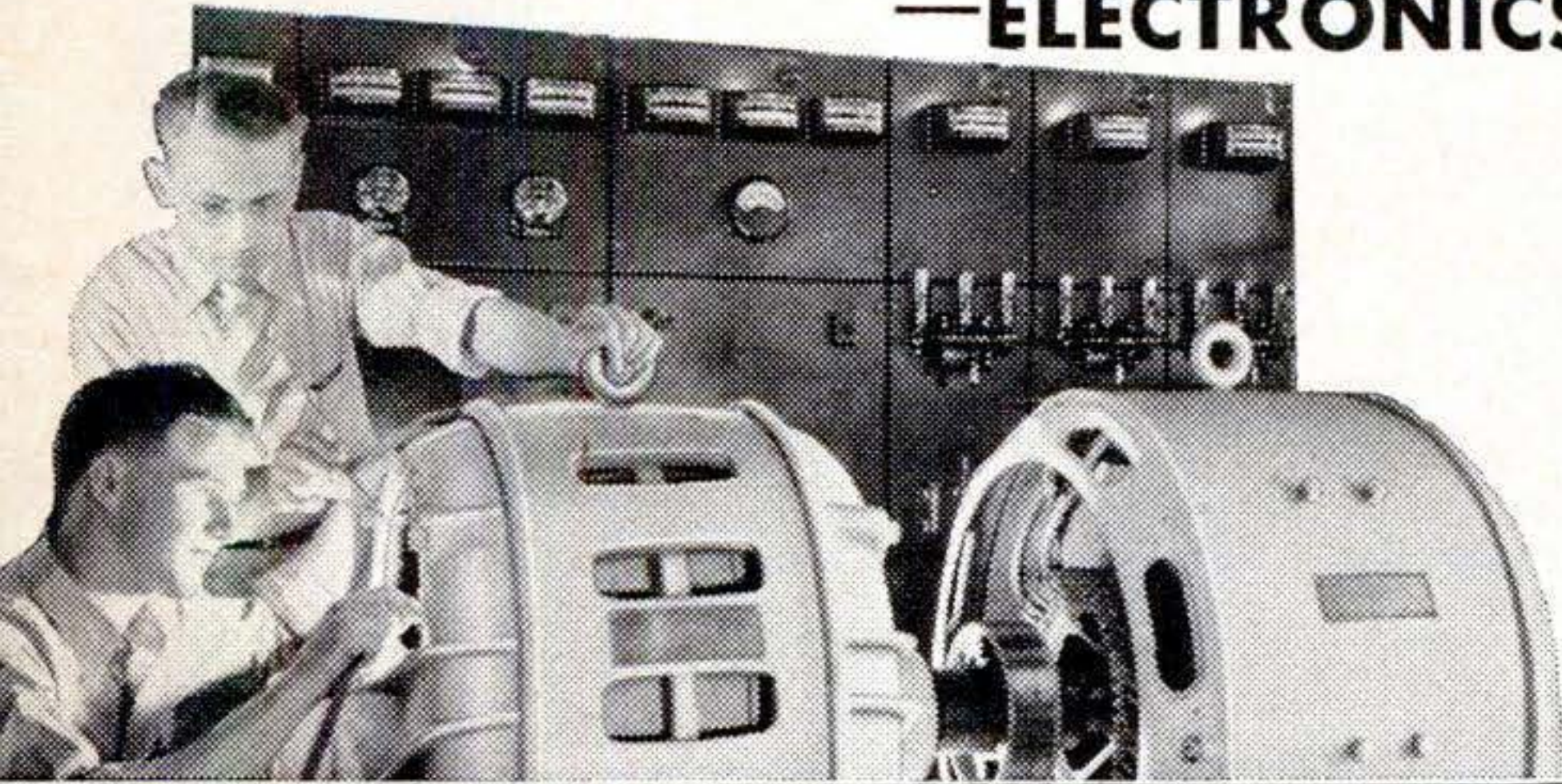

**A.C. and D.C. MOTORS
GENERATORS
SWITCHBOARDS
CONTROLLERS
WIRING JOBS
APPLIANCES
ELECTRONIC UNITS**

(Shown at left—Instructor explaining operation and testing of a large Motor Generator in our A.C. Department.)

AND **TELEVISION-RADIO**

On Real:

**TELEVISION
RECEIVING SETS
Including Color TV
AM and FM RADIO
RECEIVERS including
AUTO RADIOS
TELEVISION TEST
EQUIPMENT**

(Right — Instructor helping students check the wiring and trace circuits of television receivers.)



Train in the great SHOPS of COYNE

Largest, Oldest, Best Equipped School Of Its Kind In The U. S.

Whether 17 or up to 45 years of age, prepare for your future now. Don't be satisfied with a "No Future" job. Train the Coyne way for a better job in a field that offers a world of opportunities in the years ahead.

FINANCE PLAN Enroll now, pay most of tuition later. Part-time employment help for students. **WE TRAIN YOU IN CHICAGO** on real equipment. Trained instructors show you how, then you do practical jobs yourself. No previous experience or advanced education needed.

CLIP COUPON NOW for big new illustrated Coyne book "Guide to Careers in ELECTRICITY and TELEVISION-RADIO". No obligation; no salesman will call. Get vital facts now! *Training in Refrigeration and Electric Appliances can be Included.*



*Mail Coupon for
Big Free Book*

Training Offered
to **VETERANS**
and
NON-VETERANS
Alike

**B. W. COOKE, Jr., President
COYNE ELECTRICAL SCHOOL**

500 S. Paulina St., Chicago 12, Ill. Dept. B8-4C

Send **FREE** book and details of all the training you offer. This does not obligate me and no salesman will call. I am especially interested in:

- ELECTRICITY-ELECTRONICS
 TELEVISION-RADIO

NAME.....

ADDRESS.....

CITY.....STATE.....

B. W. COOKE, Jr., Pres. **COYNE** FOUNDED 1899
ELECTRICAL SCHOOL

**A TECHNICAL TRADE INSTITUTE OPERATED NOT FOR PROFIT
500 S. PAULINA STREET, CHICAGO, Dept. B8-4C
ELECTRICITY ★ RADIO ★ TELEVISION ★ REFRIGERATION ★ ELECTRONICS**

Keeping the Home Shipshape



SODA STORAGE IS EASY. Cut holes $3\frac{1}{2}$ " in diameter in a wooden shelf and screw it 4" from the floor of a cabinet or closet so that the floor acts as a base for the bottles.

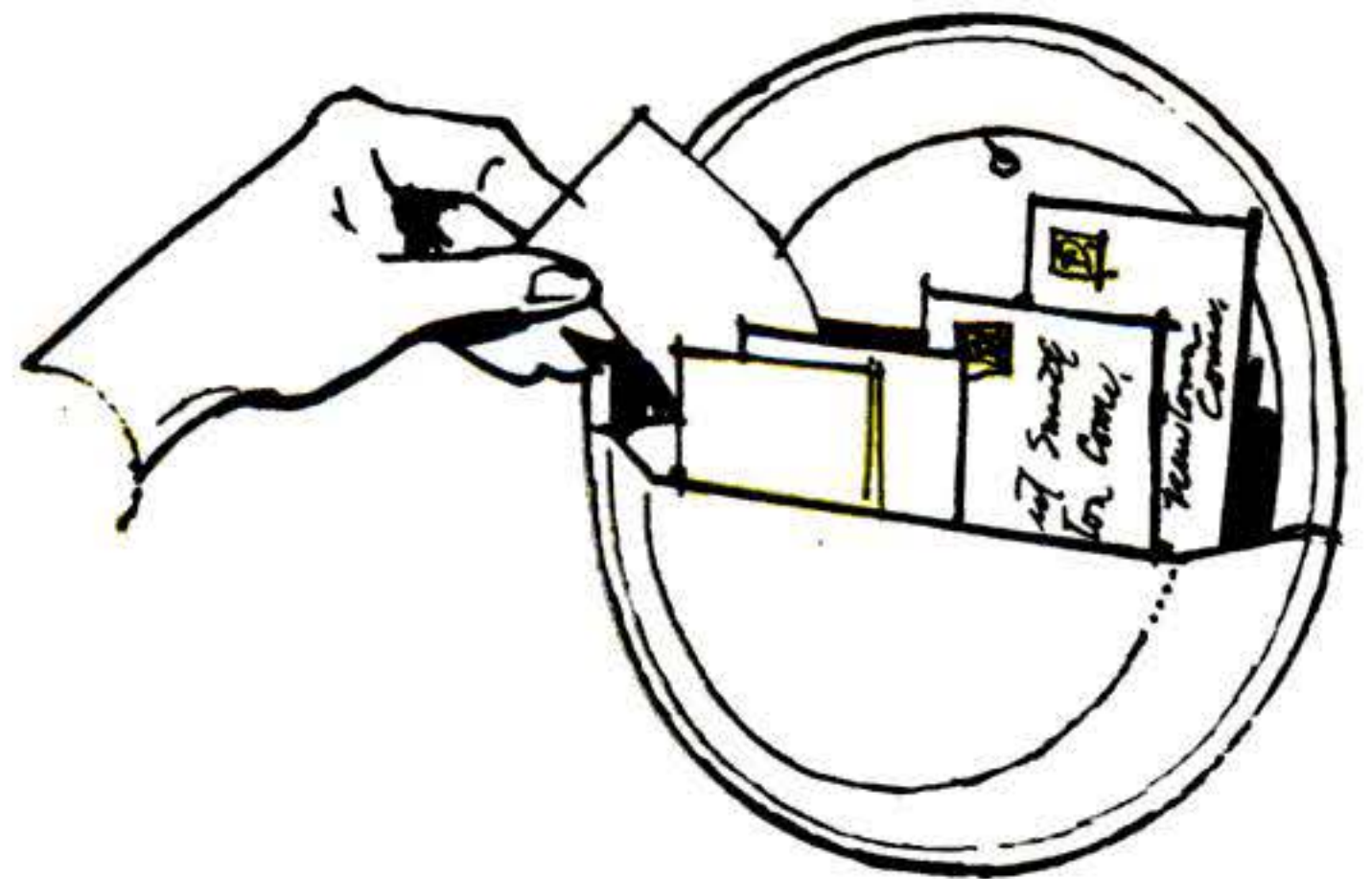

A KITCHEN WALL RACK FOR LETTERS, bills or memos can be made from two pie tins, one cut in two. Solder one of the halves to the whole tin with rim facing rim to form a pocket.

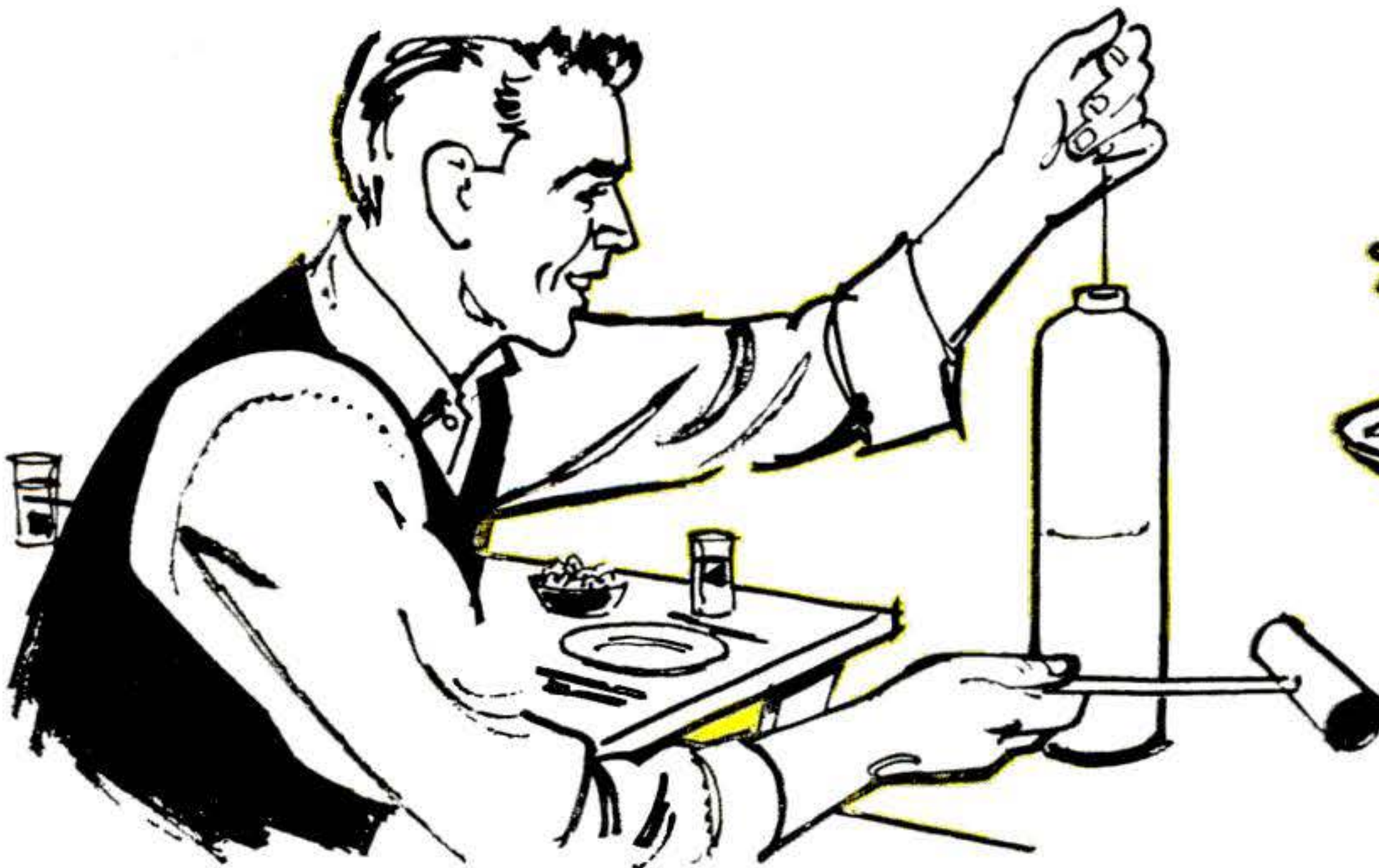

NEED A DINNER BELL on the porch or patio? An empty propane-torch cylinder makes a good

one. When struck with a small hammer or a metal rod it will sound off with a clear ring.



Burton

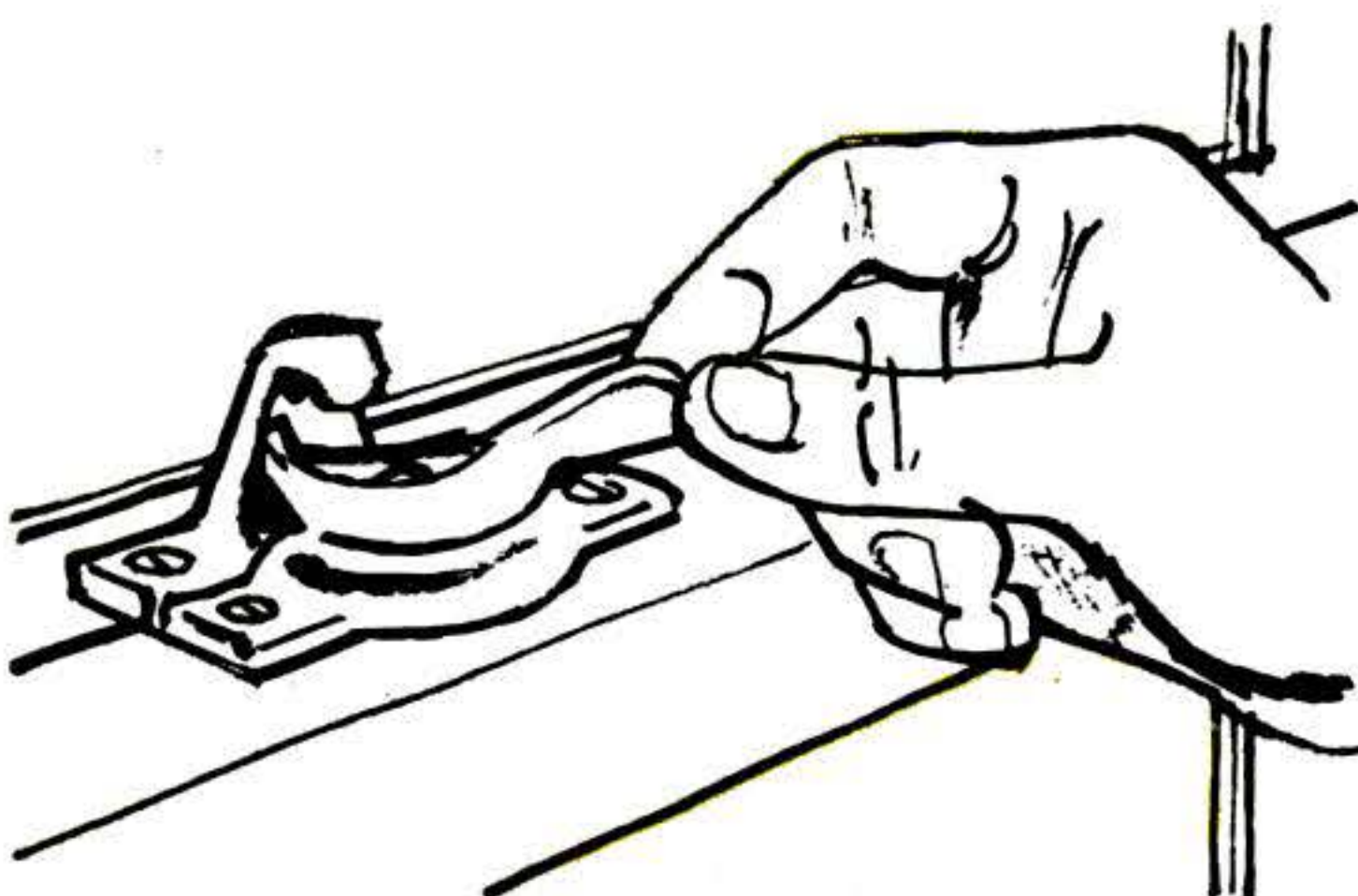

HOUSE AIR CONDITIONED? Lock the windows to eliminate cracks that admit hot air. Even where weatherstripping is used, the pressure of the lock gives you a much tighter seal.



HANG UP HANDBAGS, umbrellas, anything with a handle. Fasten a strip of perforated hardboard to a closet wall. Leave $\frac{3}{8}$ " of space behind panel for insertion of metal hangers.

Men 17 to 55 - GET FREE FACTS!

See How **DeVry Tech** Can Prepare You For A Profitable Future In Many Fields

from **Communications** to **Guided Missiles, etc.**

No Previous Technical Experience Or Advanced Education Needed!

Laborers and bookkeepers, store clerks, shop men, farmers, salesmen — men of nearly every calling — have taken the DeVry Tech program and today have good jobs or service shops of their own in Electronics. You don't have to quit your present job. If you are 17 to 55, see how you may get yourself ready for a future in the fast-growing Electronics field.

Whether you prepare at home or in our well-equipped Chicago or Toronto Laboratories, you get sound, basic training in both principles and practice. At home, you use educational movies. You build actual circuits and test equipment. You read simple directions, follow clear illustrations. When you finish, you are prepared to step into a good job in this excitingly different field. You may even start a service shop of your own. Mail coupon for free facts today.

Get **FREE** Booklet!

We'll give you a free copy of an interesting booklet, "Electronics and YOU." See for yourself how you may take advantage of the opportunities in this fast-growing field.



Radar



Automation Electronics



Television



Micro-Waves



Computers



Broadcasting



Your Own Service Shop

FREE EMPLOYMENT SERVICE

Keep you in touch with job opportunities — or helps you find a better position in the plant where you are now employed.

Draft Age?

You have valuable information for every man of draft age; so if you are subject to military service, be sure to check the coupon.

DeVry Technical INSTITUTE

Chicago 41, Illinois
Formerly DeFOREST'S TRAINING, INC.

"One of North America's Foremost Electronics Training Centers"
Accredited Member of National Home Study Council



DeVry Technical Institute
4141 Belmont Ave., Chicago 41, Ill., Dept. PS-7-0
Please give me your FREE booklet, "Electronics and YOU," and tell me how I may prepare to enter one or more branches of Electronics as listed above.

Name _____ Age _____
Street _____ Please Print Apt. _____
City _____ Zone _____ State _____

Check here if subject to Military Training.
DeVry Tech's Canadian Training Center is located at 626 Roselawn Avenue, Toronto 12, Ontario

2040

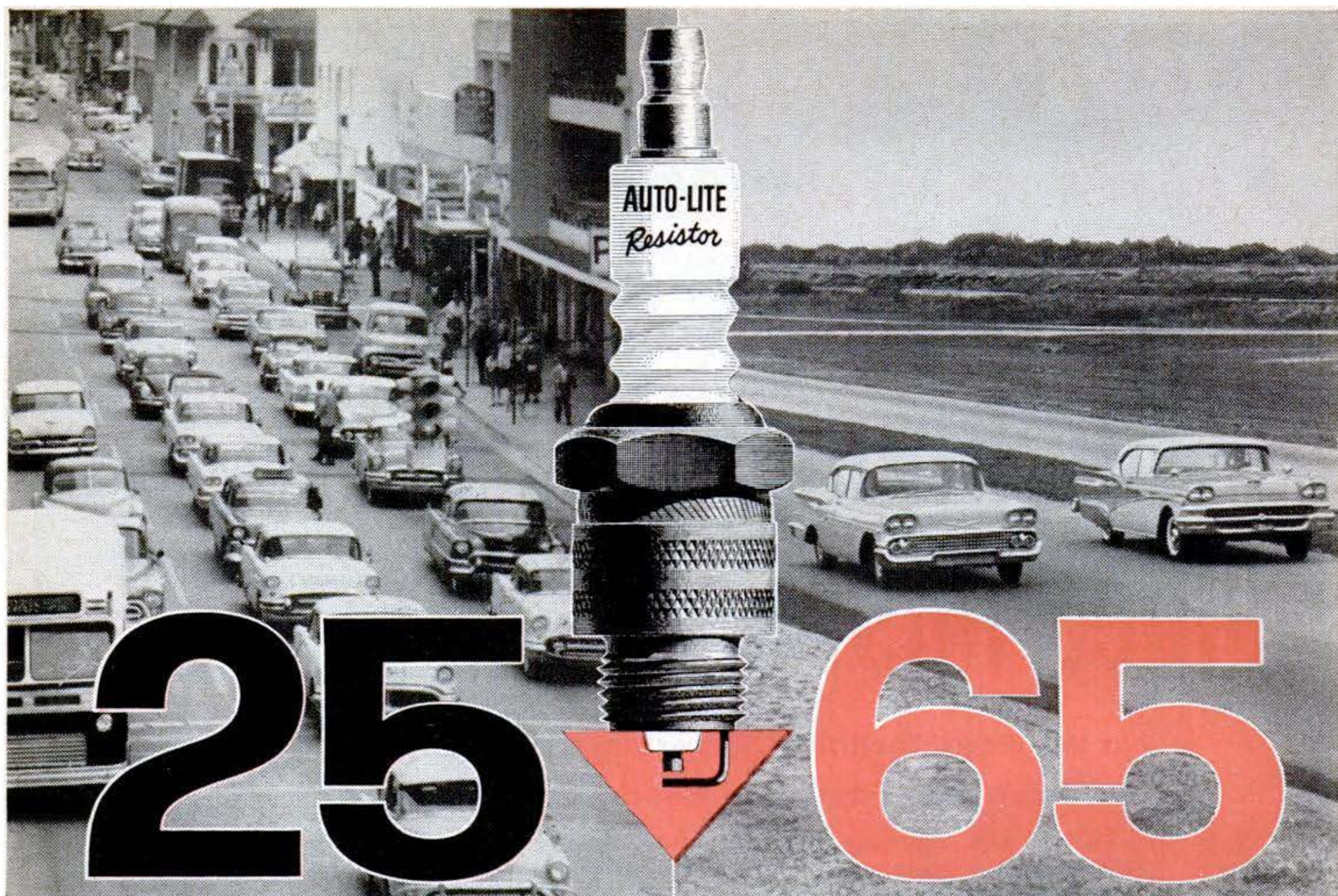

IN TOWN TRAFFIC . . . some spark plugs, designed for high speeds, become fouled and cause misfiring and loss of power when driven at low speeds.

ON THE HIGHWAY . . . some spark plugs, designed for low speeds, misfire causing power loss and invite destructive pre-ignition when driven at high speeds. Why gamble when . . .

Auto-Lite Resistor Spark Plugs with **POWER TIP** "Fire Up" your engine* at all speeds!



If you drive at both town-traffic and highway speeds, here's why you should use Power Tip . . . the first spark plug ignition-engineered for today's engines and today's driving.

YOU CAN SEE
 THE BIG NEW
 DIFFERENCE IN
 SPARK PLUGS!

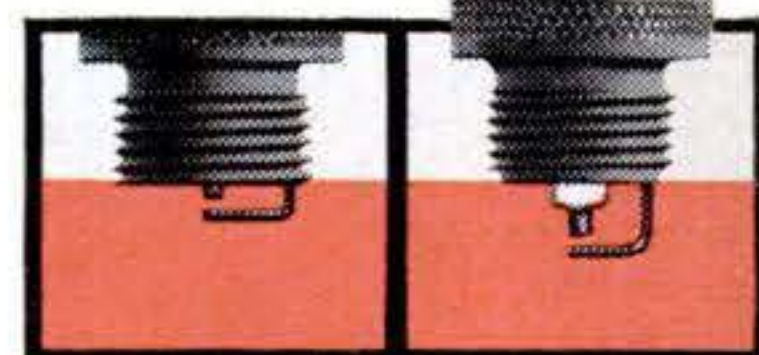

Ordinary Tip

Power Tip

Power Tip protrudes farther into the combustion chamber for better ignition. Fuel burns more evenly and completely to give top performance and economy at *all speeds*.

At low speeds, the projecting Power Tip is in the thick of combustion where it gets hot quicker and stays hot to burn fouling deposits away *clean*. At higher speeds, the projecting tip is in the path of the incoming air-fuel mixture where it stays cooler to effectively *check* power-robbing pre-ignition. Ask your garage or service station to install Auto-Lite . . . the *only* spark plugs with Power Tip . . . and start enjoying top performance and economy from your car at *all speeds*.

*Power Tip, with or without Resistor, is ignition-engineered for overhead-valve V-8 engines and for most overhead-valve 6-cylinder engines in all these cars—Buick, Cadillac, Chevrolet, Chrysler, De Soto, Dodge, Edsel, Ford, Hudson, Imperial, Lincoln, Mercury, Oldsmobile, Nash, Packard, Plymouth, Pontiac, Rambler, Studebaker.

AUTO-LITE RESISTOR SPARK PLUGS WITH **POWER TIP**

Auto-Lite makes a complete line of spark plugs, including Standard, Resistor, Marine, Small-Engine, Transport, and Aircraft.

You ought to know...

Your family car costs more to run these days. You probably knew that all along. But here are some hard figures (see table below) to back it up. These costs were compiled by a Chicago transportation-research firm, and released through the American Automobile Association.

AUTOMOBILE OPERATING COSTS			
VARIABLE COSTS (average per mile)	1956	1957	% Change
Gas & oil	2.42¢	2.39¢	down 1%
Maintenance	.74¢	.79¢	up 7%
Tires	.53¢	.59¢	up 11%
Total	3.69¢	3.77¢	up 2%
ANNUAL FIXED COSTS	1956	1957	% Change
Insurance Fire, theft	\$ 16.48	\$ 21.37	up 29%
Damage, liability (\$25-50,000)	\$ 86.92	\$ 95.35	up 10%
License & registration	\$ 17.60	\$ 19.16	up 9%
Depreciation	\$514.00	\$565.42	up 10%
Total	\$635.00	\$701.30	up 10%

Source: Runzheimer & Co. via American Automobile Assn.

The figures won't apply to your car right down to the last penny. Variables make costs highly individual. Take gas and oil consumption. It depends upon many elusive factors, such as tire pressure, driving habits, accessories. The condition in which you keep your car will influence the rate of depreciation. But you can use the table as a reliable standard for comparison, a good national average. The company based its calculations on low-price, standard-size U.S. cars:

late-model six-cylinder Fords, Chevies and Plymouths.

Yearly costs are easy to figure. Multiply the total of variable costs per mile by your total annual mileage. Add that to the annual fixed costs. As mileage goes up, it becomes more economical. Five thousand miles cost \$890. But for about \$200 more, you can double the driving and go 10,000 miles.

Styling may push prices higher on the 1959 cars. One main reason: advanced designs in windshields and windows. The more style you get, the costlier the research and engineering.

Sneak peeks at the 59s show that glass is getting a bigger play than ever. The wraparound windshield is living up to its name. It's becoming longer and higher, particularly in the Chevrolet, and possibly the other GM lines.

Chevy's wraparound windshield goes well back into the roof panel. Glass on some models runs so far back that the steel roof panel has shrunk to four feet in length, a cut of between two and three feet.

This monumental glassware the stylists are dreaming up will cost you in more ways than one. Shattered by a tire-tossed rock, a futuristic windshield could run up a repair bill as expensive as a minor head-on collision of 10 years back. That in turn will probably mean higher premiums for your collision insurance.

Watch out for confidence men. With dollars harder to come by, frauds of all kinds are mushrooming and luring easy victims.

The Federal Bureau of Investigation says that con men are

You ought to know...

plucking more "pigeons" than ever, and raking in untold millions. The State of New York recently opened a consumer-frauds division in its attorney general's department. Suddenly, the division was swamped with 100 fraud cases a week. Fraud tricks are as old as the Trojan horse. But they still work with ridiculous simplicity. People are falling for these well-worked frauds:

- ▶ **Home improvements.** "I'm in business for myself and can keep my costs down for you," says the typical gyp contractor. He may do only \$2,000 worth of work, but padding doubles the bill.
- ▶ **The "model-home" gimmick.** A more artful form of fraud, it works like this: An alleged contractor offers to reroof your house. He claims he'll show it as a model home to other prospects. And he'll give you \$50 for each showing that pays off in a new job. Actually, you get cheap roofing, and no \$50 dividends.
- ▶ **Credit-card frauds.** If you own or work for a business that deals directly with the public, check credit cards carefully. Con men are getting a lot of mileage and meals on stolen credit cards. And, incidentally, guard your own cards. You won't enjoy getting the bill if someone else has gotten the merchandise.

▶ **Come-on advertising.** This is worked primarily in big cities. Some examples: (1) A company sells sewing machines, with the phony offer to buy back piece-work done on them. This routine is also sometimes tried with power tools. (2) An ad claims the lowest of low prices. But at the store, you find the bargains are "nailed to the floor." Paint at \$3.75 a gallon comes in colors you wouldn't use on a dog house. But the salesman tries to unload full-priced products on you. (3) You buy an expensive item, say a car. You're asked to leave the sales contract with the dealer for checking. But they deliver a much cheaper model. And you have no contract to prove what you bought.

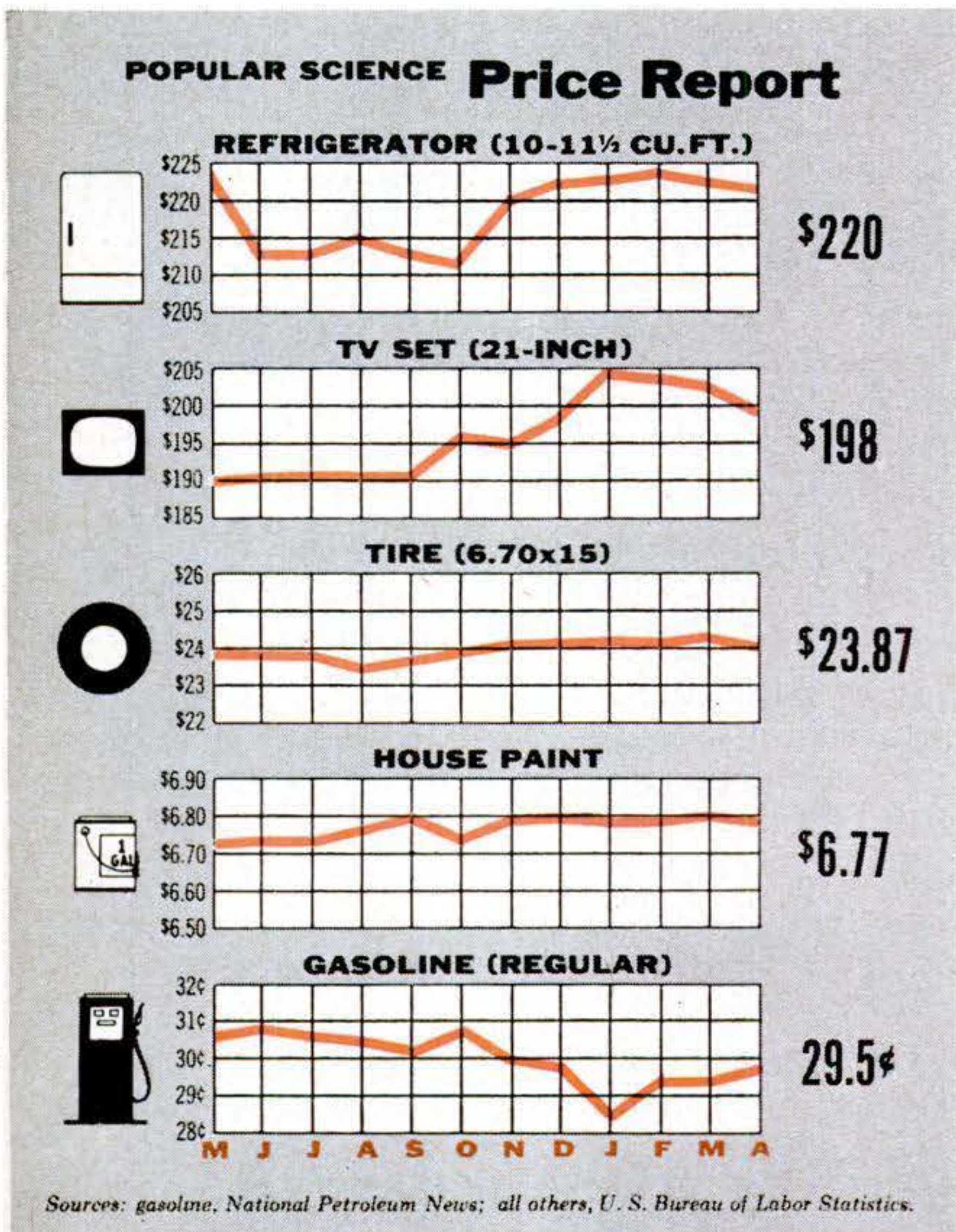

Title registered; contents copyrighted

Charles M. Gurney

GOOD NEWS for men who need GOOD JOBS!

R. C. ANDERSON
President
COMMERCIAL TRADES
INSTITUTE

BE A TRAINED MECHANIC IN AIR CONDITIONING AND REFRIGERATION

Why let the high cost of living get you down when there's such good money to be made in the Air Conditioning and Refrigeration field! Yes, this old, established, but fast-growing industry *needs thousands of trained mechanics* to install, repair and service the 150 million refrigeration units in use today. And the industry is growing! Last year, over 3 million refrigerators, 1 million freezers and 2 million air conditioners were sold. Small wonder there's a shortage of trained men! And those who are in the field earn top wages, work steady, put money in the bank!

Train at home in spare time for a better job in this uncrowded industry. For complete information, fill out and mail coupon. Do this today.

**Great new way to learn
by practicing at home
with real equipment!**

At left, Mr. Anderson demonstrates the commercial type, heavy-duty, 1/4 h.p. refrigeration high-side which you build as part of your training.



Many students earn cash as they train

Many students, soon after they start training, do repairing in spare time. They work with local dealers evenings and week-ends. Others go "on their own." They earn extra cash, get added experience. Some land full-time jobs while students, and quite a number open shops. All this is possible because CTI training is so practical.

An opportunity for a business of your own!

Students often build up a list of customers which includes not just homes, but office buildings, shops, food stores and industrial plants. They contract to do servicing on a fee



basis, or simply answer calls. The Air Conditioning and Refrigeration field offers plenty of opportunity for independence. Own a shop—Be the boss!

MAIL COUPON TODAY FOR 2 FREE BOOKS

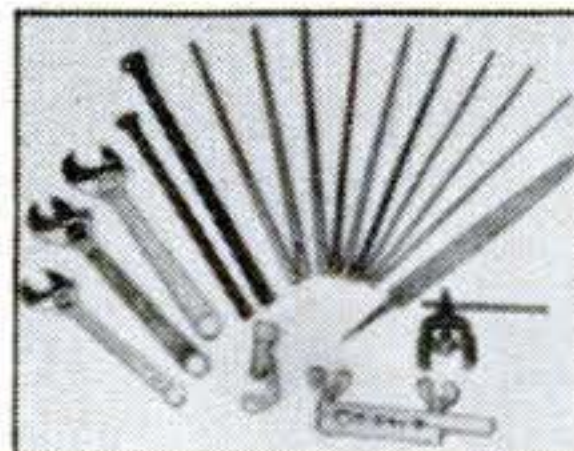

You get sound experience by training with CTI kits

Why leave home or give up your job to attend a resident school? Train at home in spare time! CTI sends you easy-to-understand instruction and 23 training kits. You get all parts and tools to build a 1/4 h.p. refrigeration condenser. You do 10 service and trouble-shooting jobs—build a freezer, refrigerator, air conditioner or milk cooler. You get practical training—intensive experience. (Two of the 23 kits are shown at left.) Act now: Mail coupon! No obligation.

COMMERCIAL TRADES INSTITUTE

1400 GREENLEAF AVENUE
CHICAGO 26, ILLINOIS

DEPT. R-500

Rush me your booklet, *Success in Air Conditioning & Refrigeration*, and *Sample Lesson*. Both FREE.

Name _____ Age _____

Address _____

City _____ Zone _____ State _____



"TRAINING YOU CAN TRUST"

"I'd like to see them make..."



SHADED EYEGLASSES to block out glare. A shallow overhang on the frame would have the same effect as holding your hand against your forehead.—*R. Blagden, E. Hampton, Conn.*



COME-APART CAR RADIATORS with a top chamber that comes off like the oil pan of the engine. Then you could do a complete radiator-cleaning job at home.—*L. J. Bump, Vineland, N.J.*

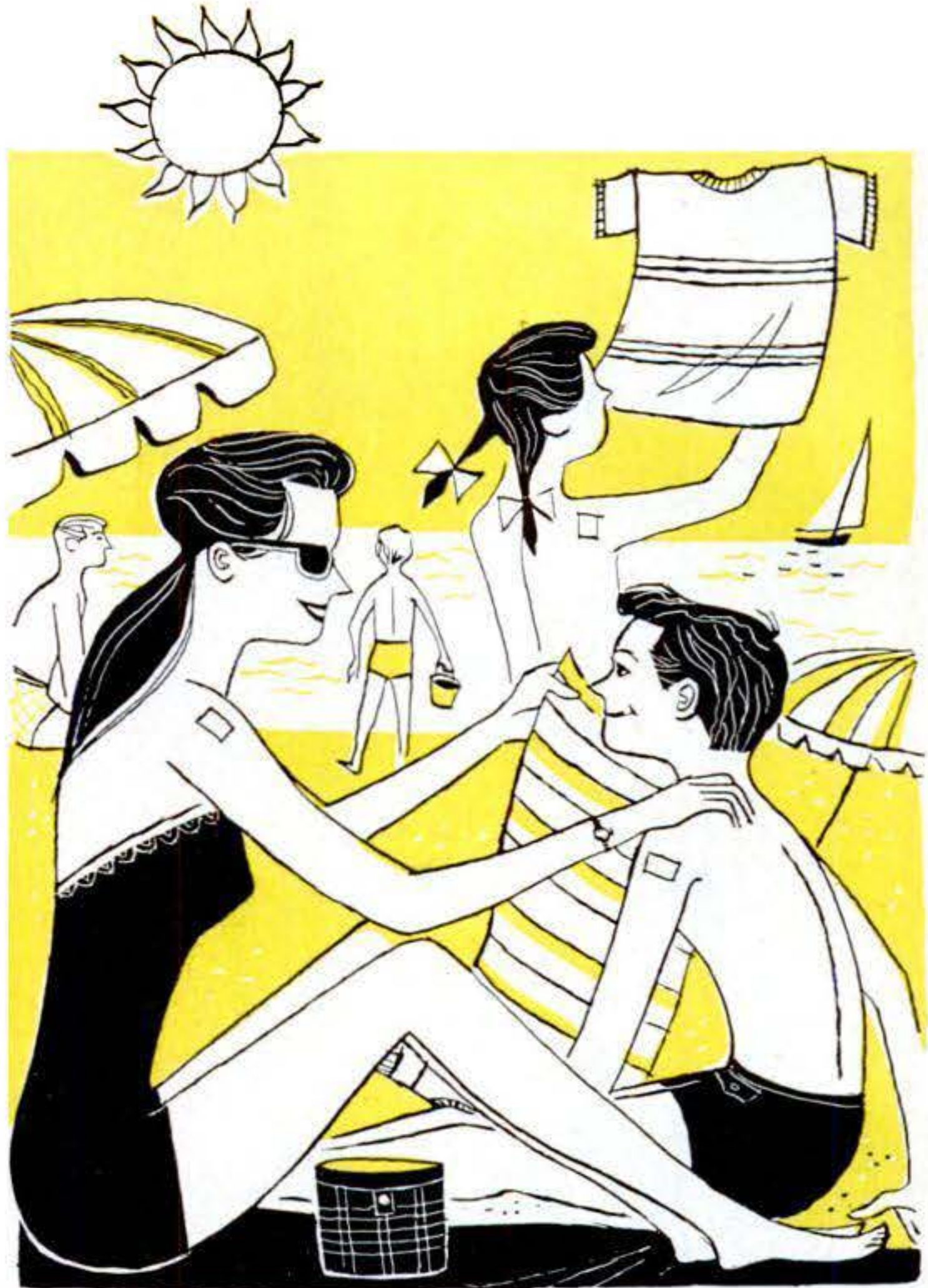

PATCH TESTERS FOR SUNBATHERS to prevent bad burns. The chemically treated stick-on patch would change color when further exposure is dangerous.—*Bill Crowell, Raleigh, N.C.*



EASY-TO-SEE CROQUET WICKETS. A spanking white nylon or reinforced plastic would make durable and washable wickets, easy to spot on a lawn.—*W. J. Inman, Silver Spring, Md.*

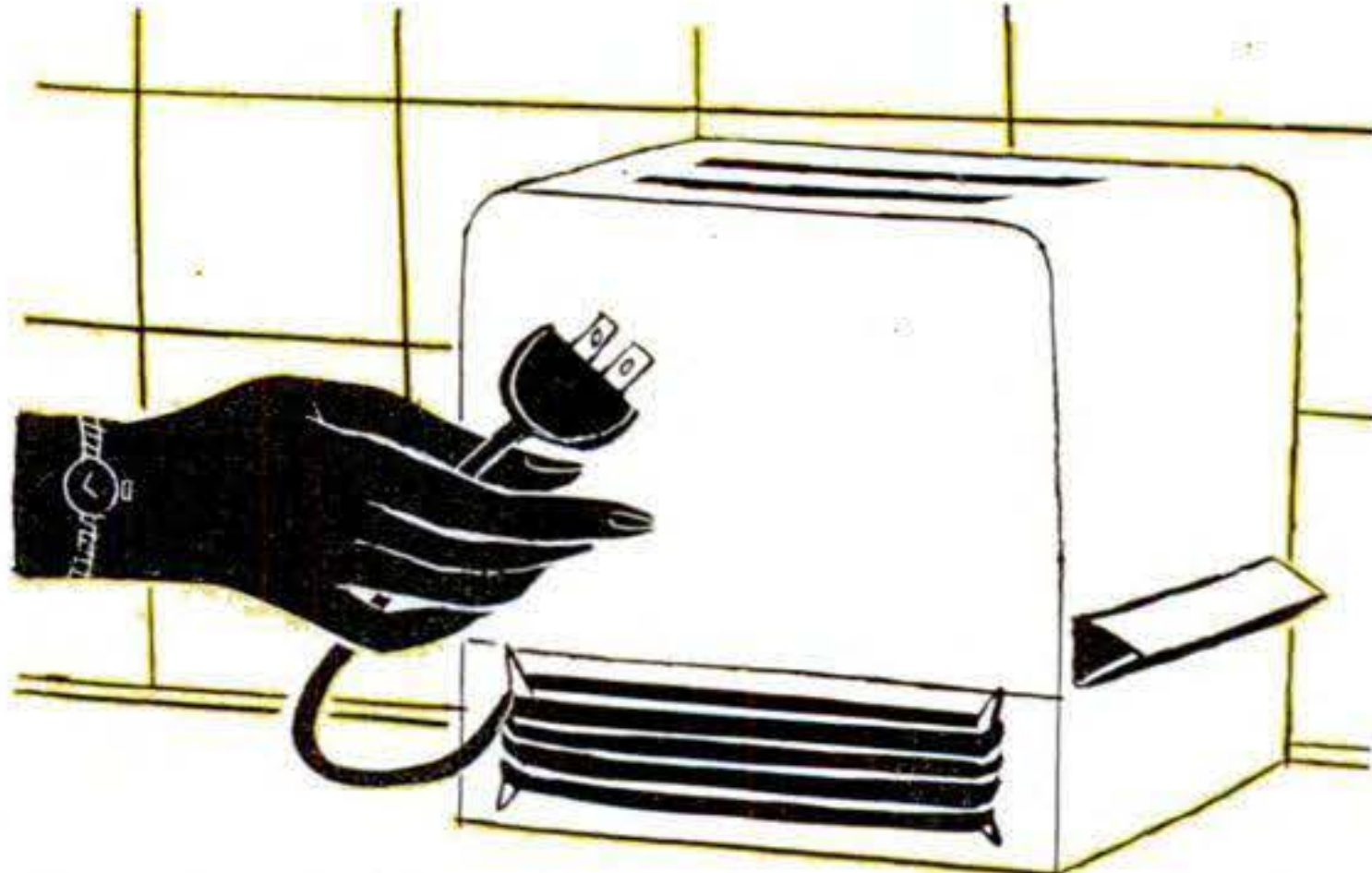

CORD-WINDING LUGS on toasters, mixers and other small appliances. Only my vacuum cleaner provides an anchorage for the extension cord.—*Mrs. A. R. Tagg, Ishpeming, Mich.*

Everyone has his own pet idea of a gadget that he would like to see in general use. The five ideas illustrated above were suggested by POPULAR SCIENCE readers. What's

yours? We will pay \$5 for each one published. Please use Government postcards only. Write name and address clearly. Contributions cannot be acknowledged or returned.

RCA INSTITUTES

Home Study Courses in
Radio-TV Electronics
Television Servicing
Color Television



RCA INSTITUTES, INC.
A Service of Radio Corporation of America

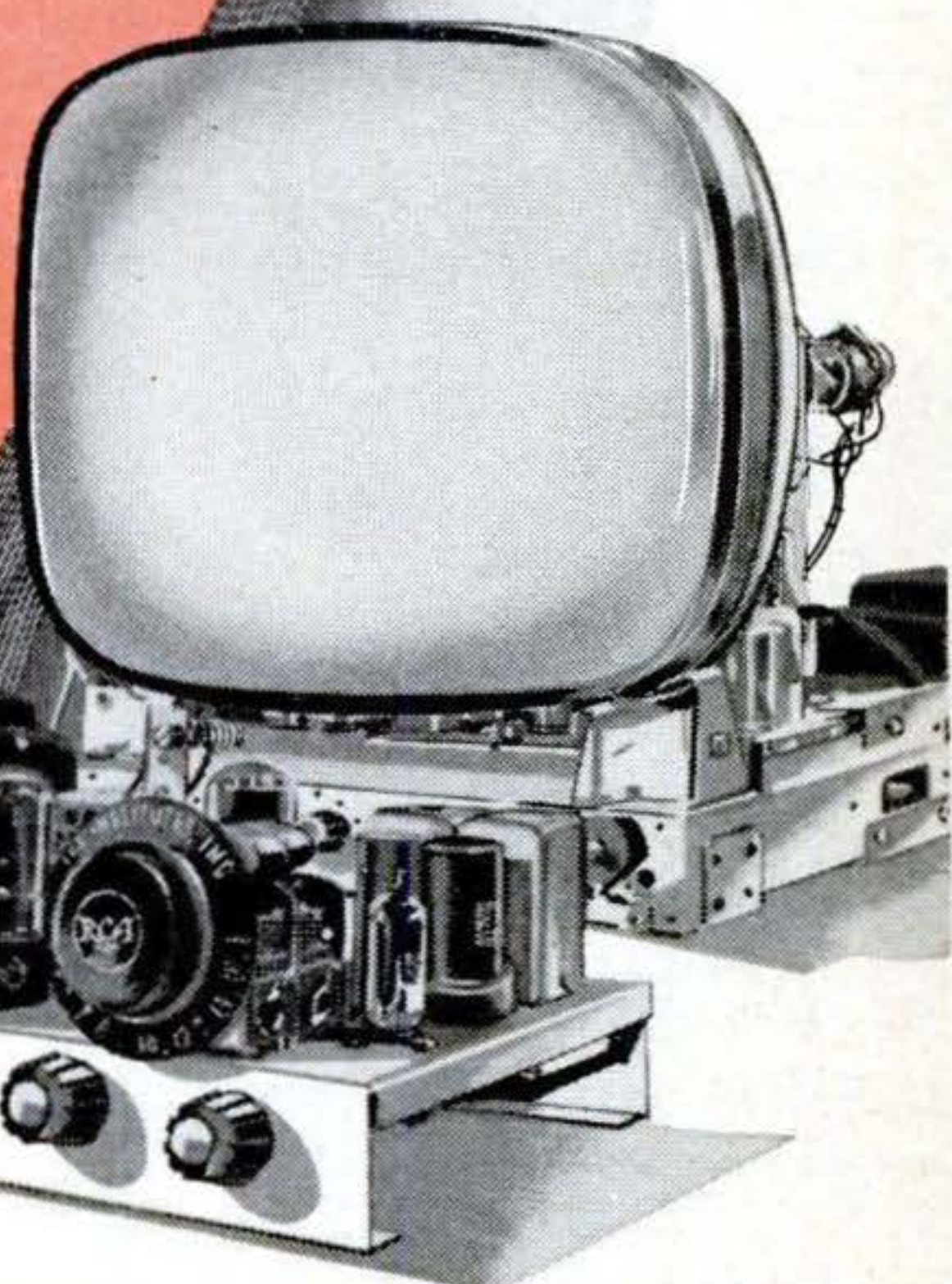
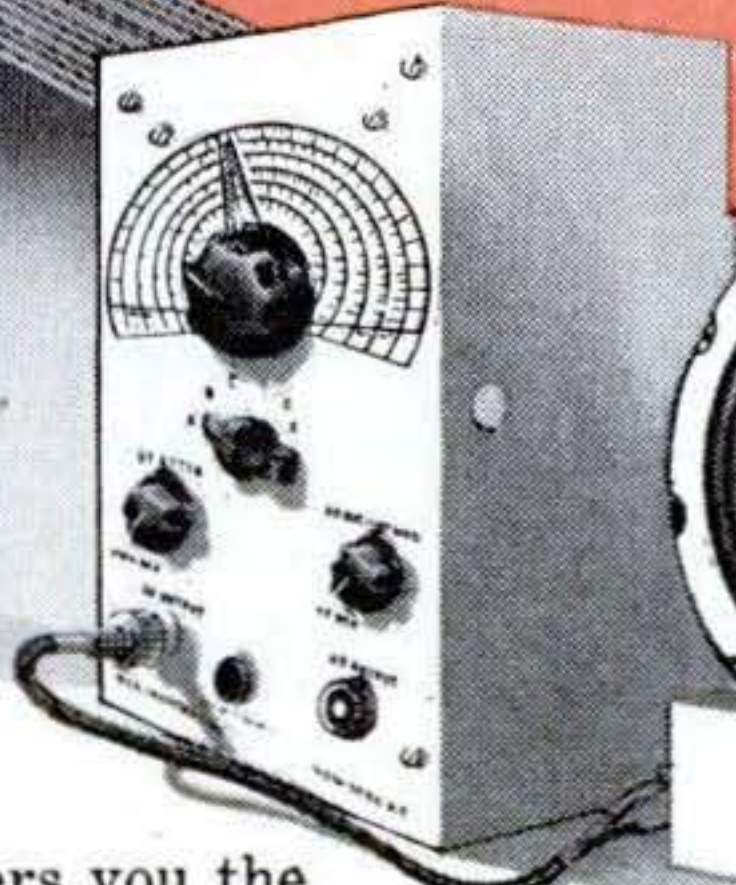

RCA INSTITUTES offers you the finest of home study training. The equipment illustrated and text material you get with each course is yours to keep. Practical work with very first lesson. Courses for the beginner and the advanced student. Pay-as-you-learn. You need pay for only one study group at a time.

**Send for this
FREE Book Now**

[RESIDENT SCHOOL courses in New York City offer comprehensive training in Television and Electronics. Day and evening classes start four times each year. Detailed information on request.]

RCA INSTITUTES, Inc. Home Study Dept. PS-78

A Service of Radio Corporation of America
350 West Fourth Street, New York 14, N. Y.

Without obligation, send me FREE 52 page CATALOG on Home Study Courses in Radio, Television and Color TV. No salesman will call.

Name.....
please print

Address.....

City.....Zone.....State.....

Korean Vets! Enter discharge date.....

CANADIANS — Take advantage of these same RCA courses at no additional cost. No postage, no customs, no delay. Send coupon to:
RCA Victor Company, Ltd., 5001 Cote de Liesse Rd., Montreal 9, Quebec
To save time, paste coupon on postcard.

Over 100,000 top pay jobs are open for
Auto Mechanics
 Now it's easy to train quickly at home



**YOU'VE GOT IT "MADE"
 WHEN YOU LEARN THIS TRADE!**



A national magazine reports, "100,000 mechanics are needed by the motor industry. If you qualify, you can go straight to the top." The vice-president of one of the "big three" says, "Technicians not only have excellent security but can count on good pay and promotion." *Don't let lack of training keep YOU from becoming a success! Learn to become a mechanic at home in spare time. Find out how by filling out and mailing coupon below. No cost or obligation.*

Get Experience Using Tune-Up Kit & Tools



CTI sends you a Tune-Up Kit, the kind that skilled mechanics use to locate engine troubles. You receive a compression Tester; Vacuum Gauge & Fuel Pump Tester; Ignition Timing Light; portable steel case. You also get mechanic's tools, including socket set. You acquire experience using kits.

DIESEL MECHANICS OR BODY-FENDER REBUILDING is yours at no extra cost. Only CTI offers this extra choice. You get fully-rounded training in all three fields.

Many Students Earn Money as They Train

Many students earn extra money fixing cars. Some work "on their own," others take part-time jobs in local shops. They add to their experience—often make enough money to pay tuition and buy equipment. A large number have gone in business, made good. Mail coupon for full information—Commercial Trades Institute, Chicago 26, Ill.

MAIL TODAY FOR 2 FREE BOOKS

COMMERCIAL TRADES INSTITUTE
 1400 GREENLEAF AVENUE
 CHICAGO 26, ILL. Dept. A-838
 Send booklet, "Big Money in Auto Mechanics," and Sample Lesson. Both FREE.

Name _____ Age _____
 Address _____
 City _____ Zone _____ State _____



Catalog of 3200 Novelties 10c

Send 10c for amazing catalog of novelties, live animals, scientific supplies, hobbies, funmakers, planes & boats, looms, magic tricks, joke articles, unusual seeds, gadget timesavers, cameras, optical goods, projectors, movies, lucky jewelry, religious novelties, disguises, musical instruments, stamps, coins, puzzles, fortune tellers, radios, auto & bike accessories, telescopes, magnifiers, compasses, banks, smokers' gadgets, artists' supplies, printing sets, engines, motors, shockers, knives, billfolds, fireworks, guns, rifles, sports, books, games, plants, etc. Send name, address & 10c to: JOHNSON SMITH & CO., Dept. 648 Detroit 7, Michigan

150 SHOT BB REPEATER PISTOL

New **BULLS-EYE 150 SHOT REPEATER**. Hard hitting, accurate firing. Centers shots in 1-inch circle at 10 feet. Shoots 30 shots a minute. Sights, feels, looks like expensive match pistol. Thumb-palm moulded checkered plastic grips. Blued steel. Shoots standard BBs. 25 shots for 1¢. 10½-in. long; weighs 1-lb. Adjustable peep-or-open sight. Includes 2 tubes BBs. **Price \$5.45** Copper-Coated Steel BBs, 3 Pkgs. 25¢
 JOHNSON SMITH & CO., Dept. 648, Detroit 7, Michigan



10-in. Balanced Throwing Knife 99c

Hunt small game. Target work, regular use. Double-edged penetrating point. Hard hitting. Balanced for easy accurate throwing. Cutlery steel. Only 99c (Sheath 50c. Knife Throwing Book 15c). Johnson Smith Co., Dept. 648, Detroit 7, Mich.

10-FOOT BULL WHIP

HARD HITTING! LOUD CRACKING! Experts knock ashes off cigars. Yank people off feet. Used by trainers, ranchmen. Loud cracker like a shot-gun blast. 4-ply hand plaited all leather. With handle loop.
 6-ft. whip \$1.98. 8-ft. \$2.69. 10-ft. \$3.29
 JOHNSON SMITH COMPANY Dept. 648 Detroit 7, Mich.

Learn To MOUNT BIRDS

Tan SKINS, Make Up FURS
 Be a Taxidermist. Double your hunting fun. We teach you at Home. Mount Birds, Animals, Pets, Heads and Fish. Save your hunting trophies; decorate home and den. **MAKE MONEY.** Mount and Krome-tan for others. Big sparetime profits. **INVESTIGATE TODAY.**
FREE BOOK with 100 game pictures. 48 pages. Hunters, get yours! It's Now Free. Send postal card TODAY--This Minute! State your AGE.
 NORTHWESTERN SCHOOL OF TAXIDERMISTRY, Dept. 2607, Omaha, Nebr.



BECOME AN EXPERT IN TRAFFIC and TRANSPORTATION

Traffic men earn \$4,000 to \$10,000 and up. Thousands of firms need experts on rates, tariffs, regulations. We train you thoroly in spare time at home for executive traffic jobs. Personal training under traffic authorities. Write for free book "Traffic and Transportation."
 LASALLE Extension University, 417 So. Dearborn St. A Correspondence Institution Dept. 783T Chicago 5, Ill.

FREE! SAMPLE LESSON TO PROVE YOU CAN LEARN RADIO-TELEVISION AT HOME IN SPARE TIME! EARN WHILE YOU LEARN

Don't wait! Prepare now for the big pay jobs and the great future offered in RADIO-TELEVISION! You can learn at home in spare time . . . and we'll PROVE it! Just send coupon below for our big new "Making Money" book and actual sample lesson . . . FREE! Get practical experience with kits we send. Earn good money while training. Get the facts . . . FREE! No salesman will call. Write today. Our 27th year!



Sprayberry Academy of Radio-Television
 Dept. 55-J, 1512 Jarvis Ave., Chicago 26, Ill.
 Mail FREE SAMPLE LESSON and Big Book.

NAME _____
 ADDRESS _____
 TOWN _____ STATE _____

RUSH COUPON Today!



INVENTORS

Learn how to protect your invention. The U. S. Patent Laws provide that any new and useful art, machine, article of manufacture, or composition of matter, or any new and useful improvement thereof, may be patented if the act of invention is involved. Therefore, every inventor with a valuable invention should take advantage of the Patent Laws and proceed for patent protection in order to safeguard his rights.

A patent gives the inventor the exclusive right to prevent others from making, using, or selling the invention claimed in the patent for a period of seventeen years.

The Patent Laws were enacted for the benefit of the inventor to give him protection for the features of his invention which are patentable. These features must be properly and concisely set forth and claimed in a formal application for patent, in order to comply with the requirements of the Patent Laws. For that reason, unless the inventor is familiar with patent matters, he should engage a competent registered patent attorney or agent to represent him. We are registered to practice before the U. S. Patent Office and are prepared to serve you in the handling of your patent matters.

A specially prepared booklet entitled "Patent Guide for the Inventor", containing detailed information with respect to patent protection and procedure, together with a "Record of Invention" form will be promptly forwarded to you without obligation upon request.

CLARENCE A. O'BRIEN & HARVEY JACOBSON

Registered Patent Attorneys

82-G DISTRICT NATIONAL BUILDING
WASHINGTON 5, D. C.

JULY 1958 23

Hey SKINNY!



...YER RIBS ARE SHOWING!

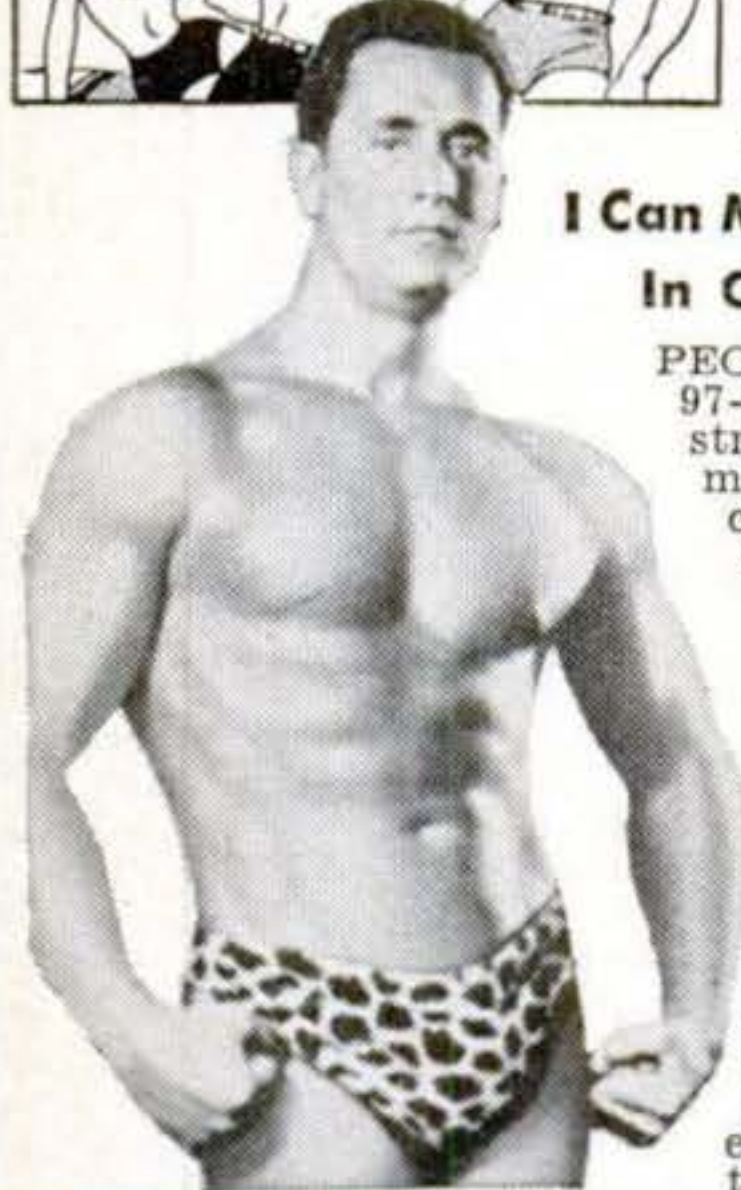
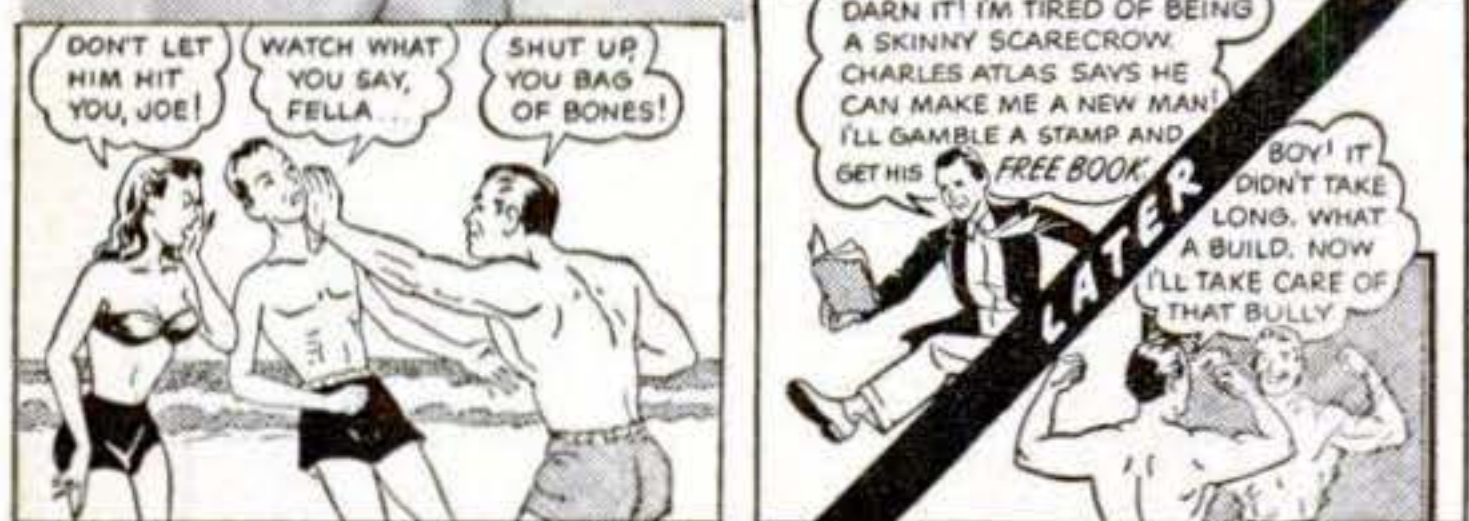

I Can Make YOU a New Man, Too In Only 15 Minutes a Day!

PEOPLE once laughed at my skinny 97-lb. body. I was ashamed to strip for sports. Girls made fun of me behind my back. THEN I discovered "Dynamic Tension." It made me such a complete specimen of manhood that I hold the title, "The World's Most Perfectly Developed Man."

What's My Secret?

When you look in the mirror and see a healthy, husky, handsome, fellow smiling back at you—you'll be amazed at how fast "Dynamic Tension" GETS RESULTS. It's the easy, NATURAL method you can practice in your own room—JUST 15 MINUTES EACH DAY. No gadgets to fool with. You simply use the dormant muscle-power in your own body—watch it grow into solid LIVE MUSCLE. See your shoulders broaden . . . your scrawny chest swell with inches of new muscle . . . those spindly legs and arms bulge

CHARLES ATLAS
Holder of title, "The World's Most Perfectly Developed Man"

with new power . . . and your whole body starts to feel "alive," full of zip and go!

FREE My 32-Page Illustrated Book Just Mail the Coupon

Send NOW for my famous book showing how "Dynamic Tension" can make me a new man. 32 pages, packed with photographs, valuable advice, answers many vital questions. This book is a real prize for any fellow. Yet I'll send you a copy absolutely FREE. Just glancing through it may change your life. Rush coupon to me personally: **CHARLES ATLAS, Dept. 17, 115 East 23rd St., New York 10, N. Y.**



CHARLES ATLAS, Dept. 17, 115 East 23 St., New York 10, N. Y.

Send me—absolutely FREE—a copy of your famous book showing how "Dynamic Tension" can make me a new man. 32 pages, crammed with photos, valuable advice. This book is mine to keep, and sending for it does not obligate me in any way.

Name _____ Age _____
(Please print or write plainly)
Address _____
City _____ Zone _____ State _____



college graduates get ahead faster!

You see it in your own city. They have higher incomes . . . advance more rapidly. Grasp your chance for a better life. Industrial growth . . . automation . . . technical advances create career opportunities for engineers, accountants, management experts. Share rewards awaiting college men. Important firms visit campus regularly to employ Tri-State College graduates. Start any quarter in this world-famed college. *Approved for veterans.*

Bachelor of Science degree in 27 months

In Mechanical, Civil, Electrical, Chemical, Aeronautical, Radio (TV Electronics) Engineering. In 36 months a B.S. in Business Administration (General Business, Accounting, Motor Transport Management majors). Superior students may accelerate. 36-weeks course in Drafting. *Intensive program:* technical fundamentals stressed; comprehensive courses with more professional class hours. *Small classes:* personalized instruction. Enrollment limited. Preparatory courses. *Beautiful campus.* Well-equipped, new and modernized buildings and laboratories. Enter Sept., Jan., Mar., June, Ernest, capable students (whose time and budget require accelerated courses and modest costs) are invited to write *Jean McCarthy, Director of Admissions, for catalog and book "Your Career in Engineering and Commerce."*



TRI-STATE COLLEGE

578 College Avenue • • • Angola, Indiana



MANUFACTURE this BEAUTIFUL OUTDOOR FIREPLACE in YOUR OWN BACKYARD

\$4.00 worth of sand and cement produces this attractive fireplace. Sells on sight from \$60 to \$80. Easy to start your own profitable business in your backyard. No experience necessary. Big profits. Exclusive manufacturing territories. Write immediately for full details. General machines sold to U.S. Government. Dealer inquiries invited.

GENERAL ENGINES CO., INC. Dept. SF-78 Rt. 130 Thorofare, N. J.

MONEY for MEN ALL DATA FREE

THE PLASTEX Industry needs manufacturers on small scale and for big production of Lamp and Clock Stands, Art Goods and Novelties in Plastex and Marble imitation. Experience unnecessary, 1/2c material makes regular 10c store sellers. Rubber moulds furnished for speed production. Small investment brings good returns. We are now placing big chain store orders with manufacturers. Ambitious men have chance for real prosperity. Our Free booklet will interest and benefit you.

PLASTEX INDUSTRIES, Dept. 2, 3400 Third Ave., New York 56, N.Y.

MEN WANTED

Earn \$100 Per Week and up

AUTO DIESEL MECHANICS

Master a trade with a future—learn Auto-Diesel mechanics in our shops. You learn with tools on real equipment. Earn while you learn. Many of our graduates earn \$100 per week and up. No previous experience necessary. Day and night courses. *Approved for veterans.* Write for free bulletin.

NASHVILLE AUTO-DIESEL COLLEGE

226 7th Ave., N., Dept. 41 Nashville 3, Tenn.

RUPTURED

BE FREE FROM TRUSS SLAVERY

Surely you want to THROW AWAY TRUSSES FOREVER, be rid of Rupture Worries. Then Why Do you put up with wearing a griping, chafing and unsanitary truss the balance of your life? If you do, it will NOT be through necessity but through choice on your part.

Now there is a new modern Non-Surgical treatment that is designed to permanently correct rupture. These Non-Surgical treatments are so certain, that a Lifetime Certificate of Assurance is given. Write today for our New FREE Book that gives facts that may save you painful, expensive surgery. Tells how non-surgically you may again work, live, play, love and enjoy life in the manner you desire. There is no obligation.

Excelsior Hernia Clinic, Dept. 3705, Excelsior Springs, Mo.

INVENTORS

If you believe that you have an invention, you should find out how to protect it. The first step is to have a search made of the prior pertinent U. S. patents. If a report on this search indicates that the invention appears patentable you can apply for a patent, and the specifications and claims should be prepared.

The firm of McMorrow, Berman & Davidson, with offices in Washington, D. C., is qualified to take the necessary steps for you. We can make a preliminary search on your invention, advise you whether we think it can be patented, and prepare your application for patent.

Unless you are fully familiar with the U. S. Patent Laws, we recommend that you engage the services of a Registered Patent Attorney to protect your interests. The patent laws are *your* laws. A patent gives you the right to prevent others from making, using or selling the invention claimed in your patent for a period of 17 years.

Use these patent laws for your protection. Investigate whether your invention can be patented. If you have what you believe to be an invention, we suggest that you have this firm make a search for you.

Send for a copy of our Patent Booklet entitled "How To Protect Your Invention," containing information about patent protection and patent procedure. Along with this we will also send you an "Invention Record" form, for your use in writing down and sketching details of your invention. We will mail them promptly. No obligation. They are yours for the asking.

McMORROW, BERMAN & DAVIDSON

Registered Patent Attorneys

PATENTS • COPYRIGHTS • PATENTS

142-R VICTOR BUILDING, WASHINGTON, 1, D.C.

DRAFTSMEN



**CASH BIG
PAY CHECKS!**

Train Now for
more success,
greater security

**LEARN AT HOME IN SPARE TIME
(or at college in Chicago)**

Check the want ads in any newspaper—SEE the big-pay opportunities open to you as a draftsman. What's more, you can learn this well-paid, prestige profession at home—quickly, easily! No special talent needed! Get complete, step-by-step Chicago Tech lessons in the mail, spend a few pleasant hours studying each week. In a short time you'll be a well-trained draftsman, ready to take your pick of many good jobs. Act now!



FREE INFORMATION—MAIL COUPON TODAY!
Get **FREE TRIAL LESSON** plus information about C.T.C. practical training. Learn what successful Chicago Tech graduates say about high pay and opportunities in drafting. No charge, or obligation.

CHICAGO TECHNICAL COLLEGE

H-226 Tech Bldg., 2000 So. Michigan Ave.
Chicago 16, Illinois
Mail me **FREE Lesson** with information about big opportunities in **DRAFTING**.

Name Age.....
Address.....
City.....Zone.....State.....

BE A DIESEL-AUTO MECHANIC EARN \$450 MONTH AND UP

WHY WORK FOR LOW PAY or worry about being laid off? We have a nation-wide waiting list of good pay jobs for our graduates.

THAT'S YOUR GUARANTEE that we offer the best in Diesel-Auto training. Costs less because you get both Diesel and Auto training for the price of one.

WITH OUR PRACTICAL "learn-by-doing" shop practice method, we train you thoroughly in less time.

IF YOU'RE DRAFT AGE:—Our catalog contains information vital to you!

Part-time jobs and housing provided. Write at once for free booklet.

GI
APPROVED!

**WORLD
FAMOUS
BAILEY TECHNICAL SCHOOLS**
1650 S. GRAND AVE. • ST. LOUIS, MO.

95% PROFITS YEAR 'ROUND

Be your own boss, Operate a **SIMPLEX** lawn-mower sharpening service in your community. One compact machine grinds all mowers, sharpens cutlery. Low investment, 95% profit. Pays for itself in average month.

SIMPLEX

—4 Machines in One!

Reel Grinder—sharpens any mower reel in or out of mower.
Bed Knife Grinder—grinds with either round or cup wheel.

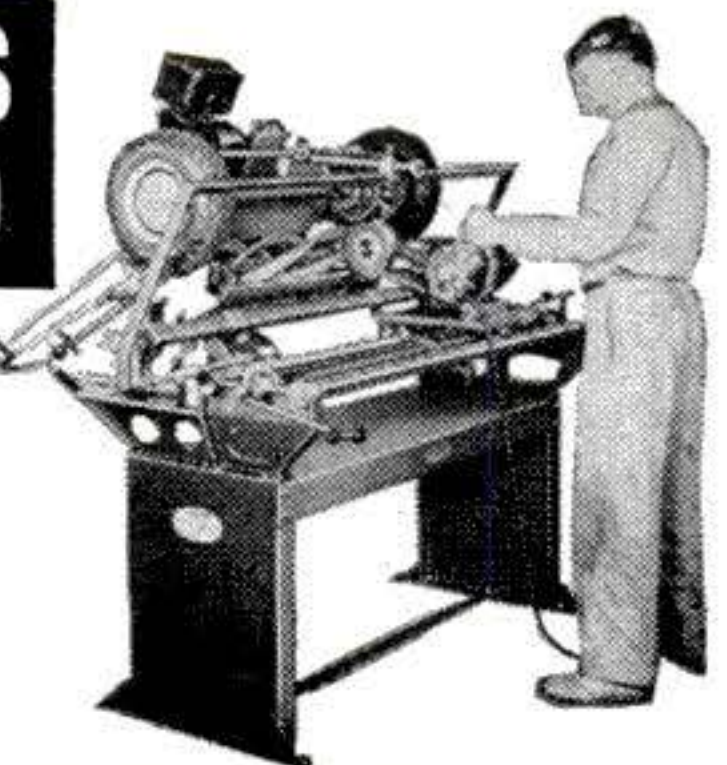

Rotary Blade Grinder—hollow grinds any rotary mower blade.
Cutlery Knife Grinder—sharpens cutlery, tools, scissors.

Send for free, money-making details!

The **FATE-ROOT-HEATH Company** • Dept. PS-7 • Plymouth, Ohio

PELLET FIRING

"45" CALIBRE AUTOMATIC

• Magazine Loading Clip • Fires 8 Rounds
• 15 Moving Parts • Fully Automatic

Automatic Full Size model of high powered "45" calibre, contains over 15 moving parts. Loads 8 complete rounds in magazine clip which snaps into hard butt like army "45". Fires 8 bullet-like pellets. Automatic slide action.

LEARN THE WORKING MECHANISM OF A "45"

Comes to you disassembled with all the working parts of a "45". Assembles in a jiffy and full instructions are included plus full supply of pellets and man-size silhouette target. Money back guarantee.

Send \$1.98 plus 25c shipping charge. (For genuine leather hip holster add \$1.50). Send cash, check or money order to:

BARGAIN (GUN) COMPANY, Dept. PS-7, One Park Avenue, New York City

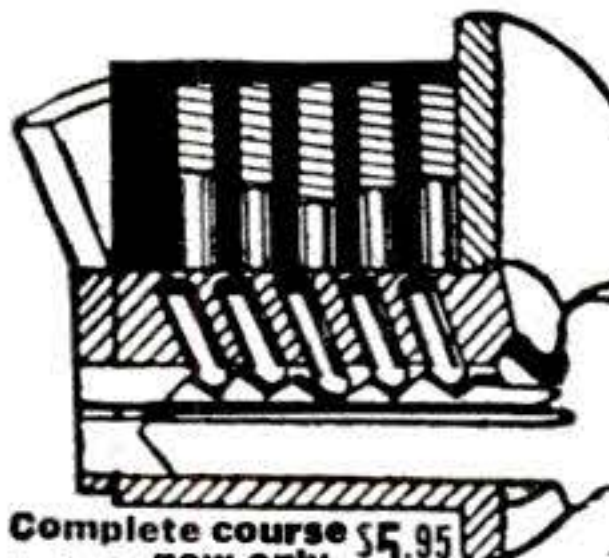

Locksmithing AND KEY MAKING

Now Made Easy! Practical up-to-date course

teaches you how to pick locks, de-code, make master keys, repair, install, service, etc. New self-instruction lessons for every handyman, homeowner, carpenter, mechanic, service station operator, fix-it shop, hardware dealer, gunsmith. 53 easy illustrated lessons. Full price only \$5.95, post-paid; or C.O.D. plus postage. Satisfaction or refund guaranteed.

Complete course \$5.95
... now only \$2.95

Nelson-Hall Co., Dept. GS-1
210 S. Clinton St., Chicago 6, Ill.



\$2.95 OR 2 FOR \$5.00

TESTED AND GUARANTEED

Write for free list on all types of telephones. Shipments F.O.B. Simpson, Pa.

TELEPHONE ENGINEERING CO.
Dept. 7A8 Simpson, Pa.

REAL ESTATE BE A BROKER

PAYS BIG! SEND FOR FREE, BIG, ILLUSTRATED CATALOG NOW! Graduates report making substantial incomes. Start and run your own business quickly. Men, women of all ages, learn easily. Course covers Sales, Property Management, Appraising, Loans, Mortgages, and related subjects. **STUDY AT HOME** or in classrooms in leading cities. Diploma awarded. Write TODAY for free book! No obligation.

Approved for World War II and Korean Veterans
WEAVER SCHOOL OF REAL ESTATE (Est. 1936)
2020S Grand Ave. Kansas City, Mo.



RUPTURED? NEW LASTING RELIEF

ENJOY NEW FREEDOM

of action, peace of mind and comfort at work or play. Proven, patented **MILLER** holds your rupture back Day and Night—will bring you lasting relief! Has helped thousands of others!

For **FREE** facts in plain wrapper—
Send Name and Address to
FRED B. MILLER, DEPT. 3-K
Manufacturer, HAGERSTOWN, MARYLAND

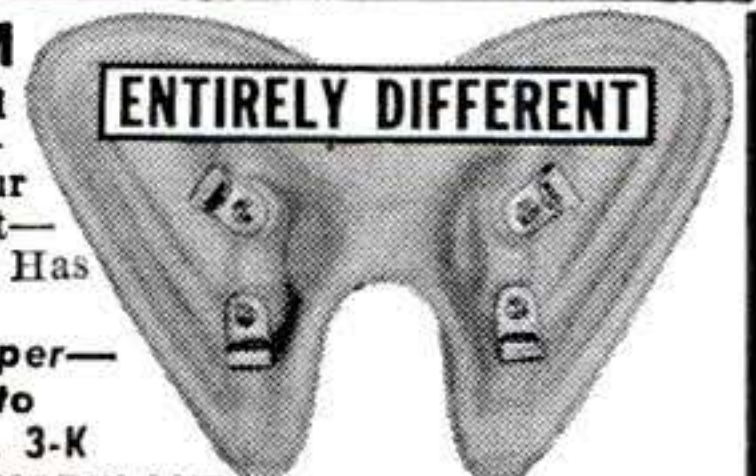

ENTIRELY DIFFERENT

MAGIC MAIL PLAN

that comes with this Little Machine
CAN MAKE YOU \$5.00 AN HOUR

The machine is turning out a job that will bring operator \$2.58, by mail. Material cost, only 11c!



Write today for free facts about the newest and most fascinating of all new home operated businesses. For the first time, a simplified machine brings the fabulous profits of Plastic Sealing and Plastic Laminating within reach of the small operator. Anyone can learn to operate it with a few minutes practice. Then—with our MAGIC MAIL PLAN—can get mail orders pouring in daily with cash in every envelope.

No Canvassing or Selling

Fill orders at home in spare time to start. Then expand to full time business. We even supply circulars to bring back cash and orders. Rush name for all the facts you need to start. A postcard will do. No charge.

WARNER ELECTRIC CO., Dept. L-3-H
1512 Jarvis, Chicago 26, Illinois

Don't Neglect Slipping FALSE TEETH

Do false teeth drop, slip or wobble when you talk, eat, laugh or sneeze? Don't be annoyed and embarrassed by such handicaps. FASTEETH, an alkaline (non-acid) powder to sprinkle on your plates, keeps false teeth more firmly set. Gives confident feeling of security and added comfort. No gummy, gooey, pasty taste or feeling. Get FASTEETH today at drug counters everywhere.

GET INTO ELECTRONICS

V.T.I. training leads to success as technicians, field engineers, specialists in communications, guided missiles, computers, radar, automation. Basic & advanced courses in theory & laboratory. Assoc. degree in 29 mos. B.S. obtainable. ECPD accredited, G.I. approved. Graduates with major companies. Start Sept., Feb. Dorms, campus. H.S. graduate or equivalent. Catalog.

VALPARAISO TECHNICAL INSTITUTE
DEPT. S VALPARAISO, INDIANA

LEARN EARTH MOVING

Big jobs go to men trained for them. Skilled equipment operators are now needed in the giant Federal road-building program. Intensive six and eight-week courses. Actual on-the-machine training. Most modern equipment available: bulldozers, draglines, cranes, shovels, tractors, scrapers, graders, loaders. Write today for details.



ENGINEERING EXTENSION SERVICE
Texas A&M College System
Box 236 FE Dept. PS-1
College Station, Texas

Name.....

Address.....

City.....State.....

\$388³¹

"Brikadier"
Blueprints
\$15.00

B-16

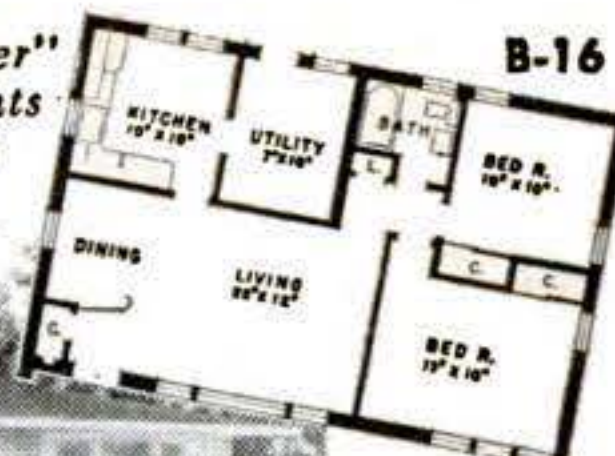

* National average. May vary by locality.

Above low price buys all the Brikrete needed for the exterior walls (8" thick) of the "Brikadier".

Brikrete Manufacturers Have the Price Advantage

- 12" long
- 8" thick
- Range of 14 colors.
- Suited to every type of building.

Drastic economies in production enable the world's most modern and practical masonry to be sold so low, yet return a generous income to the local manufacturer—100% markup on basic costs. Building owners get more usable value per dollar—plant operators profit from constantly expanding sales volume. Brikrete production is a community enterprise—processing local materials for local building activities. Plants operate in franchise-protected territories. Equipment available on 5-year payment plan. Write for Brikrete Book No. 2.



BRIKRETE ASSOCIATES, INC.
422 W. 25th Street, Holland, Mich.

Beat This for a New Job!

- ➡ Pays Up To \$100 a week to start!
- ➡ Business Expenses Paid!
- ➡ Car Furnished or mileage paid!
- ➡ We teach you at home in spare time!
- ➡ You can qualify in 6 weeks!

Automobile Claim Investigators are needed in every State in the Union. Last year alone over 25 million auto accident claims had to be settled. *And the Claim Investigator was the Key Man in every case.* There's such a shortage of trained men in this interesting field that even a beginner, with a little home training, can get good pay. Many start at as much as \$450.00 a month—many with a private office, a private secretary, a car for their personal use *and all business expenses paid!* Or you can establish a Claim Investigating business of your own—in spare time—with your home as headquarters. Claim adjusting is easy to learn, too, with my kind of "Brass Tacks" training. For many years, I was senior adjustor and head of a claim office of a company that insures over 5 million automobiles. I know the business from A to Z and can teach you quickly and thoroughly so you will be able to qualify for a Well-Paid Job in a matter of weeks. And your very first check will usually pay for the entire course! Let me send you full information Free. No salesman will call and you will not be under the slightest obligation in getting the facts. Mail the handy coupon now to me Eric P. McNair, President, Liberty School of Claim Investigating, Libertyville, Ill.



SIMPLY MAIL THE COUPON

ERIC P. McNAIR, President, Dept. 27
Liberty School of Claim Investigating
LIBERTYVILLE, ILLINOIS

Please tell me all about how I can quickly become an Auto Claim Investigator in my own community. It is clearly understood that everything you send me now is free and no salesman will call.

MY NAME.....

ADDRESS.....

CITY.....Zone.....STATE.....

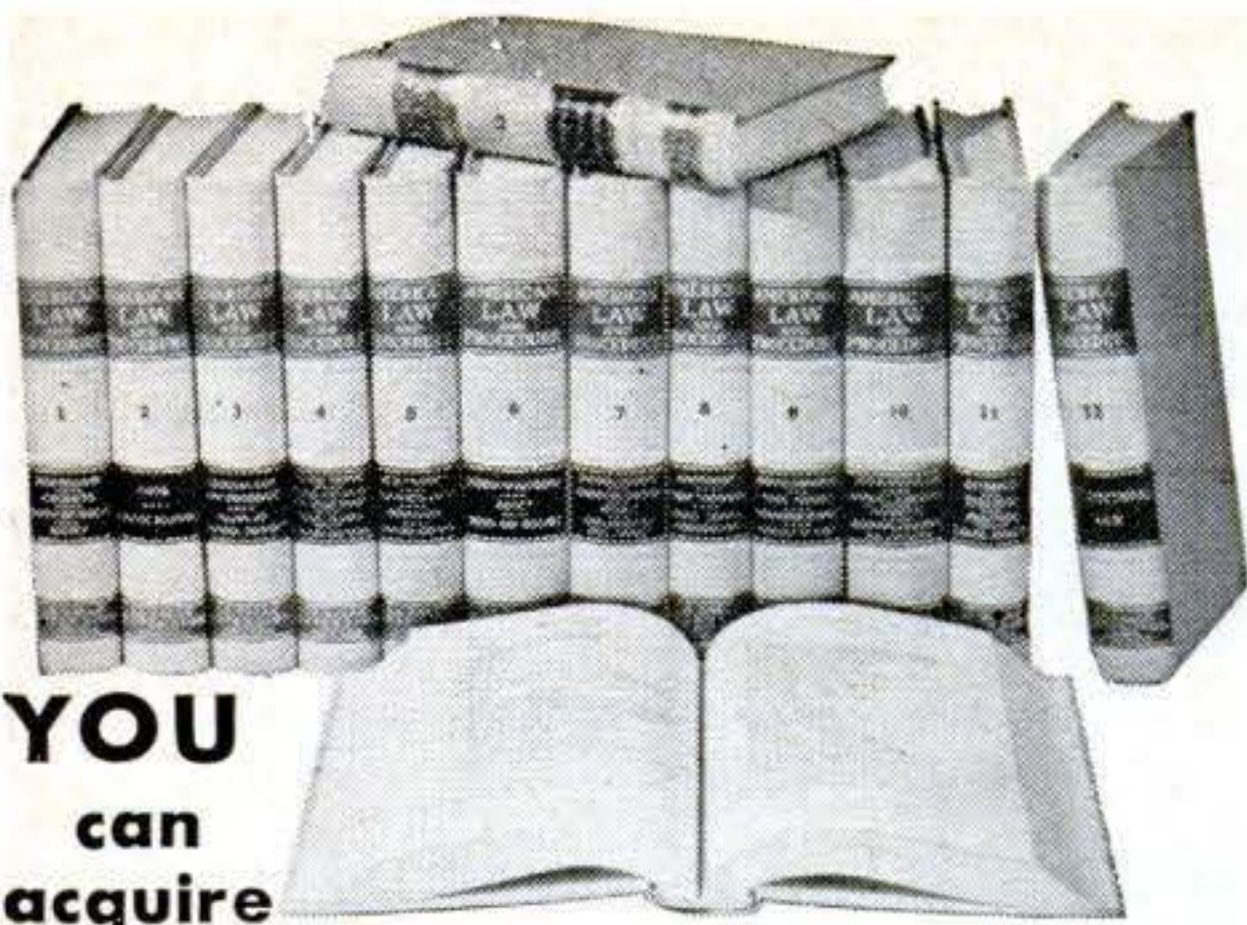

**YOU
can
acquire**

**LAW NIGHTS AT HOME!
LL. B. DEGREE**

LaSalle's famous Law Library—used as reference in many Law libraries and Law offices—has enabled thousands to master Law surprisingly fast, in spare hours at home, for business and professional advancement.

These 14 remarkable volumes, compiled by leading professors and lawyers, cover the whole basic field of Law in condensed, orderly, simplified manner.

You advance rapidly with this great library, plus special lectures furnished. We guide you step-by-step with personalized Problem Method of instruction . . . you learn by doing—handling legal problems—not by memorizing rules.

Send for two FREE booklets, "Law Training for Leadership," and "Evidence," answering questions about Law and its value to you, and telling how LaSalle Law graduates are winning rapid advancement in business and public life. Mail coupon below. No obligation.

LA SALLE EXTENSION UNIVERSITY

A Correspondence Institution

417 S. Dearborn St. Dept. 783L Chicago 5, Ill.

Send me your two FREE booklets described above, without obligation.

Name.....Age.....

Street.....

City, Zone & State.....

**EARN \$100
A WEEK AND UP**

**BE AN AUTO-DIESEL
MECHANIC...EARN
WHILE YOU LEARN**

Many of our graduates earn \$100 a week and up. You learn fast in our school and shops because you learn with tools on real equipment. Experienced instructors explain WHY and show you HOW, then you DO IT YOURSELF. One of the best equipped technical schools in the United States. Thirty-nine years' experience training men. Successful graduates in 48 states and many foreign countries. Approved for veterans. Day and evening classes. Free bulletin—write today.

NASHVILLE AUTO-DIESEL COLLEGE

226 7th Ave. N., Dept. 42 Nashville, Tenn.



**I Made \$14,839
in 1 Year
SERVICING
RADIATORS!**

Are you earning under \$8,000 a year? Many now making \$10,000-\$12,000-\$15,000 a year servicing auto-truck-tractor radiators the Inland way. Easy to learn. Inland, largest radiator equipment mfr. offers complete package—equipment, merchandising, "Pays-for-itself" financing, free training. \$305 down for equipment starts you. Profitable dept. for garage or service station. Write

INLAND MFG. CO., Dept. PS-7 1108 Jackson St., Omaha 2, Nebr.



NEW! IMPORT-Mail Order

PROFITABILITY—START AT HOME

Sell RARE EXOTIC IMPORTS

by MAIL ORDER Exclusively! No experience required, no face to face selling. We want a limited number of ambitious men and women to participate at home in a new, exclusive IMPORT-MAIL ORDER Business proposition. We do all IMPORTING, furnish expensive literature, names, addresses, and fill orders for you. All you do is mail for us and receive money coming direct to your own mail box. Hurry, for Big Profits.

MAIL ORDER DISTRIBUTORS (Import-Franchise Division)



**WANT
MORE
MONEY?**

**GET INTO
PHOTOGRAPHY**

Coast to coast, high-paying jobs in photography are waiting for people with that "know-how" to fill them. You can quickly, easily qualify at home with the world-famous NYI Learn-by-Doing Method. Write today for free catalog. Also resident training in N.Y. 48th Year. Approved for Vets.

NEW YORK INSTITUTE OF PHOTOGRAPHY

Dept. 5 10 West 33 St., New York 1, N. Y.



**Own and
Play the ACCORDION**

for fun...for popularity...for profit!

**SAVE UP TO 50%
on famous
ITALIAN MAKES**

Buy direct at amazing savings from America's biggest importer of fine Italian made accordions. **5 DAY FREE TRIAL!** Easy Terms. Free Lessons—Easy to learn. Personalized selection service. Trade-ins accepted. Write today for big Color Catalog and our low wholesale prices. **FREE!** Accordion Manufacturers & Wholesalers Outlet

**5 DAY
FREE
TRIAL**

2003 West Chicago Avenue - Dept. p-78 - Chicago 22, Illinois

STOP RUPTURE SUFFERING!

WEB GUARANTEES LASTING RELIEF

—OR YOUR MONEY BACK!

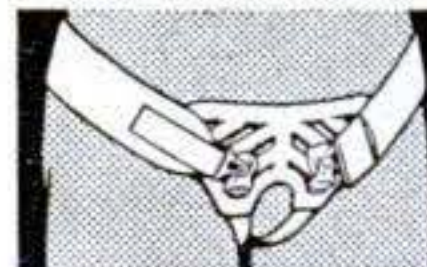

Thousands have overcome disabling ruptures with the natural support of Web's patented design. Satisfaction—or full price refunded. Write for free book!

WEB TRUSS CO., Dept. PS-7, HAGERSTOWN, MD.

**High School Course
at Home Many Finish in 2 Years**

If you did not or cannot finish high school, here is your opportunity. Study in spare time at home. Go as rapidly as your time and abilities permit. Course equivalent to residential school—prepares for college exams. Standard texts supplied. Credit for subjects already completed. Single subjects if desired. Diploma awarded. Be a High School graduate. Start studies now. Free Bulletin. Write today.

AMERICAN SCHOOL, Dept. HB46

Drexel at 58th, Chicago 37, Illinois

Superior's New
Model TD-55

TUBE TESTER

Quickly and Efficiently Tests Radio and TV Tubes Including: Seven Pin Miniatures; Eight Pin Sub-Minars, Octals and Loctals; Nine Pin Novals.

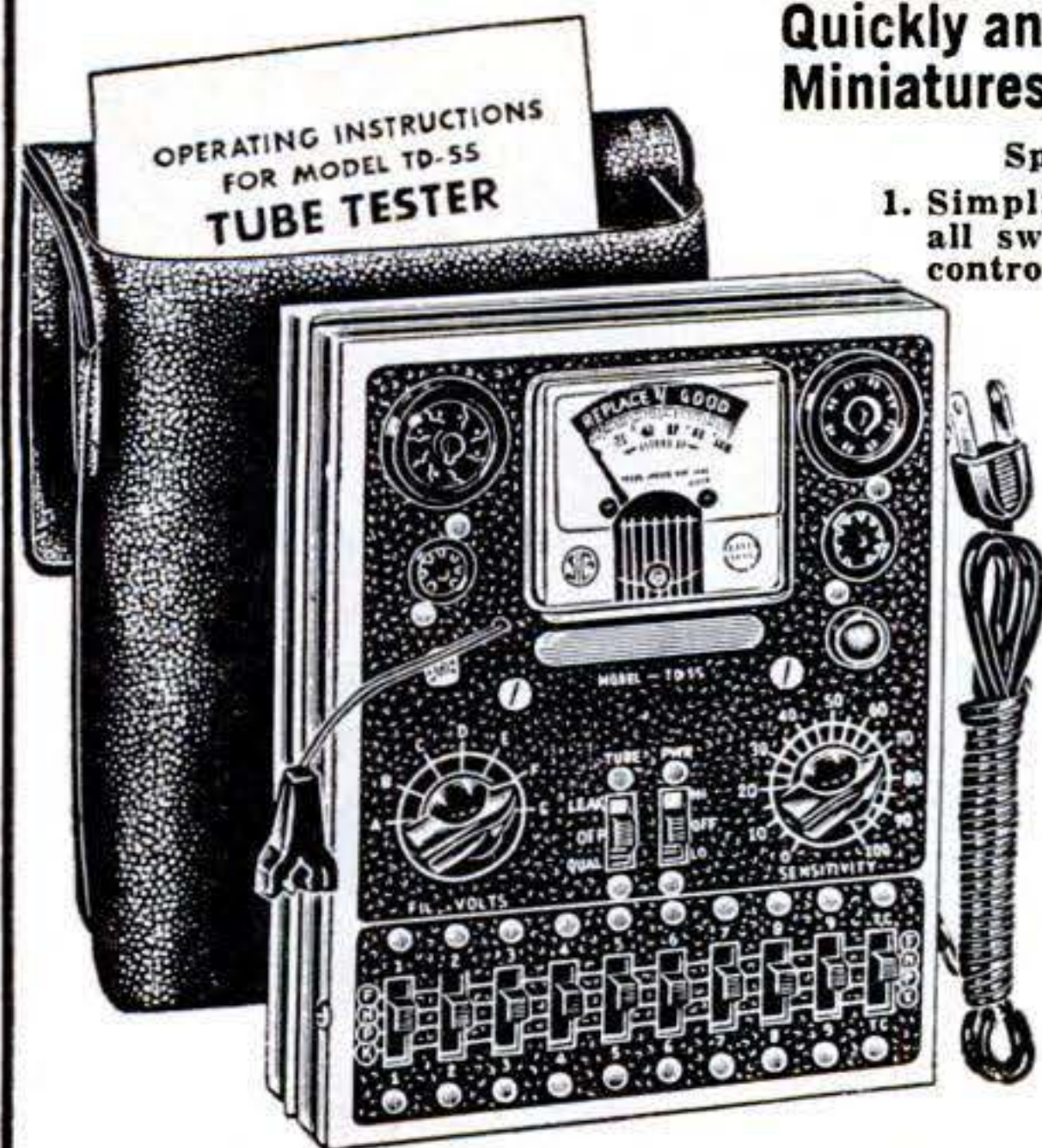

Speedy, yet efficient operation is accomplished by:

1. Simplification of all switching and controls.
2. Elimination of old style sockets used for testing obsolete tubes (26, 27, 57, 59, etc.) and providing sockets and circuits for efficiently testing the new Noval and Sub-Minar types.

You can't insert tube in wrong socket. It is impossible to insert the tube in the wrong socket when using the new Model TD-55. Separate sockets are used, one for each type of tube base. If the tube fits in the socket it can be tested.

"Free-point" element switching system. The Model TD-55 incorporates a newly designed element selector switch system which reduces the possibility of obsolescence to an absolute minimum. Any pin may be used as a filament pin and the voltage applied between that pin and any other pin, or even the "top-cap."

Checks for shorts and leakages between all elements. The Model TD-55 provides a super sensitive method of checking for shorts

and leakages up to 5 Megohms between any and all of the terminals. Continuity between various sections is individually indicated. This is important, especially in the case of an element terminating at more than one pin. In such cases the element or internal connection often completes a circuit.

Elemental switches are numbered in strict accordance with R.M.A. specification.

One of the most important improvements, we believe, is the fact that the 4 position fast-action snap switches are all numbered in exact accordance with the standard R.M.A. numbering system. Thus, if the element terminating in pin No. 7 of a tube is under test, button No. 7 is used for that test.

The Model TD-55 comes complete with operating instructions and charts. Housed in rugged steel cabinet. Use it on the bench—use it for field calls. A streamlined carrying case, included at no extra charge, accommodates the tester and book of instructions.

\$26⁹⁵
NET

**SHIPPED ON APPROVAL
NO MONEY WITH ORDER — NO C.O.D.**

Try it for 10 days before you buy. If completely satisfied then send \$6.95 and pay balance at rate of \$5.00 per month for 4 months—**No Interest or Finance Charges Added.** If not completely satisfied, return to us, no explanation necessary.

MOSS ELECTRONIC DIST. CO., INC.

Dept. D-479, 3489 Tenth Ave., New York 34, N. Y.

Please rush one Model TD-55. If satisfactory I agree to pay \$6.95 within 10 days and balance at rate of \$5 per month. If not satisfactory, I may return for cancellation of account.

Name _____

Address _____

City _____ Zone _____ State _____

All prices net. F.O.B., N.Y.C.

OWN a BUSINESS!

Earn \$8,750.00 your First Year!
Start part time if you wish. We locally train you, furnish everything to clean and mothproof rugs, upholstery on location by world-wide process. Quickly established. No shop needed. Just 2 average jobs a day bring \$8,750 net profit in year. Employ others and multiply profits. You get National Advertising, Parents' Seal, 25 other regular services. Easy terms. Send today for free booklets.
DURACLEAN CO., 8-187 Duraclean Bldg., Deerfield, Ill.

SHORTHAND IN 6 WEEKS

Famous SPEEDWRITING shorthand. 120 words per minute. No symbols; no machines; uses ABC's. Easiest to learn, write and transcribe. Low cost. 350,000 graduates. For business and Civil Service. Typing available. 35th Year. Schools in over 400 cities. Write for FREE booklet to:

Speedwriting
Dept. 2607-8
55 W. 42 St., N.Y. 36, N.Y.

MAKE STRIPES with new PAINT PEN

Straight, curved, single or double
With any color paint, stripe furniture, bikes, autos, model planes, toys, linoleum, wall-board. Clean, crisp decorative lines. Can't clog or smear. Also use with glue, tempera, textile paint or underglaze... on wood, glass plastic, ceramics, metals, fabrics and paper. Ask your dealer or order direct.

DEALERS Master paint striping tool in display carton. Write for discounts.
HOBBY "Professional" results every time. Simple, easy to use. Order now.
MFRS Ask about heavy duty industrial striping tools.

DOUBLE STRIPE MODEL \$3.25
5 COMBINATIONS.

WENDELL MFG. CO.

24234 LINCOLN AVE., Dept. 242
CHICAGO 18, ILLINOIS

Single 1/16" stripe model \$1.25

Other single stripe models \$1.75 EA.
1/64", 1/32", 3/64", 5/64", 3/32" & 1/8"

Complete Kit \$5.00 (all 7 tips)

Extra tips 90c ea.

Extra 1/4" tip..\$1.20

ENGINEERING



Photo of Heald Student in Electrical Laboratory

Enroll Now for New Term

Heald College Ranks **FIRST** West of the Mississippi in "Who's Who in America"

Send for FREE Information Please send by air. Thanks

Heald Engineering College
Est. 1863

Van Ness at Post, Dept. PS 758
San Francisco, California

NAME _____

STREET _____

CITY _____

STATE _____

American Industry Steps Up Its Demand for Trained Engineers. Train Now at Healds

BACHELOR OF SCIENCE DEGREE, 27 MONTHS

Degree Courses:

- Radio-Electronic Eng.
- Electrical Engineering
- Highway Engineering
- Mechanical Engineering
- Structural Engineering
- Civil Engineering
- Architecture

Diploma Courses:

- TELEVISION Color TV
- Radio-Electronic Tech.
- Industrial Electronic Tech.
- Tool & Die Design
- Architectural Drafting
- Mechanical Drafting
- Structural Drafting

Approved for Veterans

INVENTORS

WE recommend that you take the following preliminary steps toward patent protection. Make a disclosure of your invention; sign, date and have your disclosure witnessed by two people who understand your invention; authorize us to conduct a preliminary search among previously granted U. S. patents for similar types of invention. We give you a report on the probable patentability of your invention and our recommendation for further course of action.

Let us send you a copy of our instructive booklet, "Patent Protection for Inventors" and our convenient "Evidence of Invention" disclosure form. No obligation.

VICTOR J.
EVANS & Co. *Merlin M. Evans*
REGISTERED PATENT ATTORNEY
440-H MERLIN BUILDING, WASHINGTON 6, D. C.

SUPPRESSED KNOWLEDGE OF THE AGES

WHAT STRANGE POWERS did the ancients possess? Where was the source of knowledge that made it possible for them to perform miracles? Were these profound secrets burned with ancient libraries, or are they buried beneath crumbling Temple walls? These wise men of the past knew the mysteries of life, and personal power. This wisdom is not lost—it is withheld from the mass. It is offered freely TO YOU if, with an open mind you wish to step out of the rut of monotonous existence and MASTER YOUR LIFE.

THIS FREE BOOK

Man's intolerance has at times swept his achievements from the face of the earth, yet secret brotherhoods have preserved this sacred wisdom of the ages. The Rosicrucians, one of these ancient brotherhoods, INVITE YOU to write and secure a free copy of "The Mastery of Life." It will point out how you may receive age-old truths. You can learn to MAKE YOUR LIFE ANEW—the fulfillment of your ideals awaits you. Address: Scribe X.N.D.

THE ROSICRUCIANS
AMORC

SAN JOSE, CALIFORNIA

The Rosicrucians are NOT a religious organization

INVENTORS

Whether an invention is patentable can be substantially determined by a search of the U. S. Patent records. Without obligation, write for information explaining the steps you should take to secure a patent.

JOHN N. RANDOLPH

Registered Patent Attorney

805-Victor Building

Washington 1, D. C.

INVENTORS

Send for
PATENT INFORMATION
Book and
INVENTOR'S RECORD
without obligation

GUSTAVE MILLER

78-PSWARNER BUILDING
WASHINGTON 4, D.C.

REGISTERED PATENT ATTORNEY

ASSOCIATE EXAMINER

U.S. PAT. OFF. 1922-1929

Patent Attorney & Advisor

U. S. NAVY DEPT. 1930-1947

PATENT LAWYER



INVENTORS

U. S. Patents protect your inventions. Our free book of "Instructions on Patent Procedure for Inventors," also "Certificate of Invention" form sent without obligation.

C. A. SNOW & CO.
REGISTERED PATENT ATTORNEYS
426 SNOW BUILDING WASHINGTON 1, D. C.

INVENTIONS WANTED

If you want to market, or sell, your invention for cash or royalties, Write for our Free Booklet. Send no drawings. We also welcome hearing from firms, or private capital, wishing to review inventions in any field. We will be glad to send notice of our clients' inventions.

GLOBAL MARKETING SERVICE

2420 77th Ave.

Dept. SD

Oakland 5, Calif.

INVENTORS

PROTECT YOUR INVENTION BY A U. S. PATENT. SEND FOR FREE "INVENTION RECORD" FORM AND "PATENT INFORMATION EVERY INVENTOR SHOULD HAVE".

CARL MILLER

REGISTERED PATENT ATTORNEY

WOOLWORTH BLDG., 36th FLOOR, 78C
NEW YORK CITY

FOR A BETTER JOB . . . MORE MONEY . . . LEARN . . .

DRAFTING

AT HOME . . . QUICKLY . . . IN SPARE TIME

● THE GREATEST SUCCESS FORMULA IN THE WORLD!

Drafting is the only profession that can bring you so many benefits in just a few short months. Insure your future against layoffs and uncertainty. There is a severe shortage of skilled draftsmen that cannot be met during your lifetime! 90% of all engineering money is spent for drafting skills. If you are the type of man who enjoys the adventure of being in on the beginning of things, if you want big pay, advancement, recognition, security and a position of leadership, **DRAFTING IS FOR YOU!** Write for the full facts now!

VETERAN APPROVED!



OWN BUSINESS

The C.E.I. course I took while in the service has helped me make \$10,000 a year in my own construction co.

Victor L. Douglas,
Montana

FAST ADVANCEMENT

When I enrolled with C.E.I., I was a laborer in a pottery. I am now project supervisor in a Consulting Engr. firm.

Robert Logan, Penn.

COMPLETE EQUIPMENT FREE OF EXTRA COST!

free
LESSON AND SUCCESS BOOK



MAIL COUPON NOW!

CLEVELAND ENGINEERING INST. DEPT. PS-7H
6300 Euclid Ave. Cleveland 3, Ohio

Mechanical Aeronautical Architectural

MY NAME AGE.....

ADDRESS

CITY STATE.....

No Obligation — No Salesmen

A-1704

CLEVELAND ENGINEERING INSTITUTE



HOME-IMPORT BUSINESS . . .

Men, women. Make big profits buying low cost imports abroad (see examples at left) and selling to friends, stores or by mail order. Famous world trader guides you—shows you how to find thousands of exotic imports for full or spare time business, how to pocket profits in advance on foreign drop shipment plan. Full details FREE! Airmail reaches us overnight. Write Today!

MELLINGER CO., 1717 Westwood
Dept. P247, LOS ANGELES 24, CALIFORNIA

NEW, NATURAL LIGHTWEIGHT DENTAL PLATE



MADE FROM YOUR OLD ONE—New, Professional Method gives you natural-looking, perfect-fitting plastic plate—upper, lower or partial—from your old cracked or loose plate without an impression. CLINICAL method means fast service, huge savings. Try new plate full 30 days at our risk. New plates sent you Air Mail same day.

Now Priced Low As **\$15.95**

SEND NO MONEY—just your name and address for full particulars FREE. No cost. No obligation. Act now.

CLINICAL DENTAL LAB., 335 W. Madison St., Dept. X-1157, Chicago 6, Ill.

EYE GLASSES by MAIL As low as \$1.95

WRITE for FREE CATALOG with 14 LENS SAMPLE CARD

Thousands of Customers Est 1939



QUALITY READING — or BIFOCAL GLASSES for FAR and NEAR Recommended for folks approximately 40 years or older who do not have astigmatism or disease of the eye, and who have difficulty reading or seeing far.

ADVANCE SPECTACLE CO. Inc., Dept. SP-7
537 S. Dearborn St., Chicago 5, Ill.

EARN MORE-LEARN AUTO DIESEL MECHANICS

OR TRAIN WITH OTHER GREER DIPLOMA COURSES

- | | |
|---|--|
| <input type="checkbox"/> AUTO MECHANICS | <input type="checkbox"/> REFRIGERATION |
| <input type="checkbox"/> DIESEL MECHANICS | <input type="checkbox"/> AIR CONDITIONING |
| <input type="checkbox"/> BODY & FENDER REPAIR | <input type="checkbox"/> MACHINIST TRADE |
| <input type="checkbox"/> GAS-ARC WELDING | <input type="checkbox"/> ADVANCED MACHINIST |
| | <input type="checkbox"/> PIANO TUNING & REPAIR |

Skilled men are needed in every part of the country. Earn top pay in established shops or start your own business. Greer's expert instruction and actual shop training teaches you how. You learn by doing—quick, easy courses using the latest tools and equipment. Day, evening and part time instructions available.

Job placement and convenient living accommodations are yours while training. Contact GREER'S FREE JOB PLACEMENT SERVICE when you enroll if you wish part time or full time employment.

ENGINEERING DEGREE COURSES

- | |
|--|
| <input type="checkbox"/> DIESEL AUTOMOTIVE ENGINEERING 27 MOS. |
| <input type="checkbox"/> REFRIGERATION & AIR COND. ENGINEERING 18 MOS. |
| <input type="checkbox"/> WELDING ENGINEERING 18 MOS. |

All Courses Approved Civ. or G.I.

Please rush me free literature on the trade indicated at no obligation.

NAME _____ AGE _____

STREET _____

TOWN _____ ZONE _____ STATE _____

Established 1902

GREER SHOP TRAINING

Box G, 2238 S. Michigan Ave.
Chicago 16, Illinois

AUDELS GUIDES

MATHEMATICS MADE EASY

A COMPLETE HOME STUDY COURSE—Starting with the first principles of arithmetic, advancing step by step through the various stages of mathematics, including the rules and calculations for mechanical and electrical problems. New EASY correct methods. Includes plane and solid geometry, trigonometry, algebra, calculus, etc. Practical tests, reference tables and data. How to use slide rule. 752 Pages. 550 Illustrations. Priced at only \$3.
CIRCLE No. 11 IN COUPON

PRACTICAL ELECTRICITY

A COMPLETE HANDBOOK—Quick, simplified, ready reference. Complete instruction and practical information on the rules and laws of electricity—Maintenance of Machinery—A.C. and D.C. Motors—Armatures—Wiring Diagrams—House Lighting—Power Wiring—Meters—Batteries—Transformers—etc. Simple to understand. 1520 Pages. 2600 Illustrations. Priced at \$5.
CIRCLE No. 4 IN COUPON

REFRIGERATION & AIR CONDITIONING

FOUR BOOKS IN ONE—basic principles, servicing, operation, repair of: 1. Household Refrigeration. 2. Special Refrigeration Units. 3. Commercial & Industrial Refrigeration. 4. Air Conditioning Systems. A GOLD MINE of essential information. Completely up-to-date. 1360 Pages. Fully illustrated and indexed. Priced at only \$6.
CIRCLE No. 14 IN COUPON

AUTO MECHANICS

Big, practical book gives full information with working diagrams. Covers principles, construction, ignition, service and repair of cars, trucks and buses. Diesel Engines, Hydramatic and Fluid Drive fully explained. Priced at only \$6.
1696 Pages
1500 Illus.



CIRCLE No. 1 IN COUPON

7-DAY FREE EXAMINATION

SEND NO MONEY—Pay the postman nothing! We'll send you any of the Audel Guides for FREE examination in your home. If you decide to keep the books you may pay for them under our easy-pay plan of only \$2 a month.

HERE IS ALL YOU DO
IT'S EASY TO ORDER: In the No-Risk Mail Order Coupon below you need only draw a circle around the number of Audel Guides you want. We will send them to you at once. If you are not completely satisfied, return the books to us.

COMPLETE CATALOG SENT FREE!
CHECK BELOW

MAIL THIS COUPON TODAY!

THEO. AUDEL & CO.—Self Improvement Publishers Since 1879
49 W. 23rd Street, New York 10, N.Y.

S7

Please mail me for 7 days' FREE EXAMINATION the books I have circled. I agree to mail \$2 in 7 days on each book or set ordered, and to further mail \$2 a month on each book or set ordered until I have paid the purchase price, plus shipping costs. If I am not completely satisfied with my Audel Guides I may return them.

NAME _____

ADDRESS _____

OCCUPATION _____

EMPLOYED BY _____

1 4 11 14 Check Here for Free Complete Catalog

SAVE SHIPPING COSTS! Check here if you enclose complete payment with order. We pay postage charges. You have some return privilege.

Make \$20 to \$30 a Week EXTRA MONEY!

With the high prices of food, clothing and everything else, just think what you could do with extra money every week! Turn your spare time into CASH—sharpening saws with a Foley Automatic Saw Filer pays from \$3 to \$6 an hour. Start in your basement or garage—no experience necessary. "The first saw I sharpened with my Foley Filer came out 100%"—writes Clarence E. Parsons. No canvassing—"I advertised in our local paper and got in 93 saws"—says M. L. Thompson. With a Foley you can file all hand saws, also band and cross-cut circular saws.

FREE BOOK Shows How To Start

It explains how you can get business from home owners, farmers, carpenters, schools, factories, etc. "I get work from 20 and 30 miles away"—says Charles H. Smith. Free Book, "Money Making Facts," tells how to start. Time Payment Plan. Send coupon today—no salesman will call.

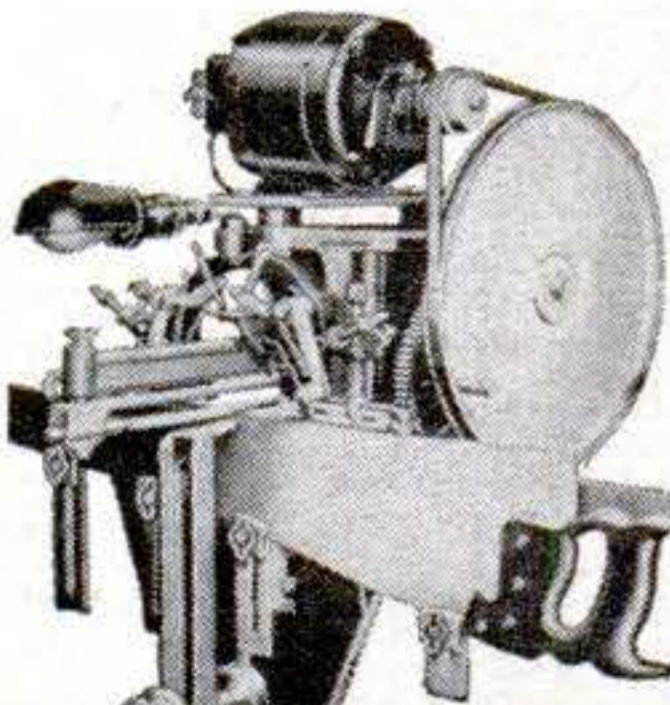

Send Coupon for FREE BOOK

FOLEY MFG. CO.
719-B Foley Bldg., Minneapolis 18, Minnesota
Send FREE BOOK—"Money Making Facts" and Time Payment Plan.

Name _____

Address _____

\$1 BRINGS YOU \$18

Discover Flok-Kraft and Earn \$\$\$\$\$ AT HOME

Earn up to \$15.00 per hour spare time. Amazing new Velvet-fiber spray instantly makes any object (Lamps, Radio & TV Cabinets, Figurines, Signs, Auto dash boards, toys, furniture, draperies—anything) worth expensive \$\$\$\$\$ Prices... like magic, you can spray anything with this beautiful new suede-like finish that feels like rich Velvet.

EARN UP TO \$300.00 PER WEEK SPARE TIME

Imagine, materials cost only 3c per square foot. (Average TV or radio cabinet can be beautifully sprayed with this startling new 3-dimensional Velvet finish in 15 minutes at a cost of only 34c in materials. Your charge for this job is at least \$10.00.)

REPRESENTATIVES IN YOUR AREA URGENTLY NEEDED

Own your own business. Work at home in your spare time. Help fill the huge growing demand for this amazing new beautiful Velvet-fiber finish. Orders come from stores, offices, homes, architects, auto dealers,—everywhere. Possible \$20,000,000.00 worth of jobs to be done. Investigate today—be first in your area!

Actual samples in 16 Radiant Colors, Booklet of 50 Home Business Opportunities and Confidential Details all sent free! Send no money. Write: Coast Industries, Los Angeles 61, Calif., Dept. A-7.

BARBELLS

140-Pound, CHROME DELUXE Barbell-Dumbbell set only \$18.80.

This is our feature set and is the finest ever manufactured.

Training with adjustable weight is the BEST way to keep fit; the ONLY way to develop great strength and a perfect body. As the oldest and best equipped barbell company, BUR gives value and prices no one can equal.

SEND FOR FREE CATALOG.
BUR BARBELL CO.
Lyndhurst 5, New Jersey

100 POUND SET \$11.80

Extra Plates Only 10c Pound

75 POWER TELESCOPE 25X-45X-75X \$3.98

NEW 3 in one telescopes, 3 variable 25X 45X-75X magnification. Brass bound, 25 power for ultra bright images 45 & 75 power for long range. Guaranteed to bring distant stars, moons, objects, sports 75 times closer.

Most powerful scope sold anywhere near this amazing low price. American made, 5 sections. Opens 36", closes 1 ft.; contains 4 ground & polished lenses. Can also be used as powerful compound microscope. Mass production enables us to offer telescope complete at \$3.98 postpaid. Money back guarantee.

CRITERION CO., Dept. PSB 61, 331 Church St., Hartford, Conn.

Find HIDDEN TREASURES

GOLD, SILVER, PRECIOUS METALS with the Famous Model 27 Metal Detector. Lightweight, ultra-sensitive, low cost. None finer. Also GEIGER COUNTERS for uranium and the VIOLITE for tungsten. INFORMATION FREE

THE *Detectron* CORP.
5528 Vineland Ave., No. Hollywood, Calif.

make your own Gems 36.50 FOB

The Gem Maker comes complete with all necessary equipment, including a super-charged diamond blade for sawing, and all the wheels for grinding, shaping and polishing; also complete instructions. The complete equipment as shown, less motor and belt for only \$36.50, f.o.b., Burlington, Wisconsin. Write today for information and literature.

B&I MANUFACTURING CO.
Dept. S, Burlington, Wis.

MEN PAST 40

Troubled With GETTING UP NIGHTS

Pains in Back, Hips, Legs, Tiredness

Then your troubles may be traced to Glandular Dysfunction... a constitutional disease. Neglect of this condition often leads to premature old age and sometimes incurable malignancy.

The Excelsior Medical Clinic has a New Free Book that tells how thousands of men have been successfully treated here at Excelsior Springs for Glandular Dysfunction by NON-SURGICAL Methods. They found soothing relief and a new outlook in the future of life.

This Free Book may prove of utmost importance in your life. Write Today. There is no obligation.

Excelsior Medical Clinic Dept. 6219, Excelsior Spgs., Mo.

MAKE MORE MONEY

these two **FREE** books will tell you how
SEND COUPON TODAY



SAVE! WATER SKI KIT

ONLY \$15.95 MONEY BACK GUARANTEE
IT'S EASY TO ASSEMBLE

AND FINISH YOUR OWN TOP QUALITY LAMINATED ASH SKIIS

Kit includes 7"x72"x9/16" Skiis, tip precurved and rounded, runners, adjustable bindings with rust-proof fittings, and complete instructions. **FREE:** Book on Water Skiing. These Skiis are strong, durable, impact resistant; smooth and responsive at all speeds. They meet the demands of the expert, yet the beginner finds them easy to handle.

SKI KIT—\$15.95. Or completely finished as in illustration \$22.95
SLALOM KIT—\$12.50. Completely finished \$17.95
75 ft. **POLYETHYLENE SKI ROPE.** "It floats" \$4.95



Send Check or M. O. direct to:
WATER SKIIS, N. A. E., Inc.,
4106 BEECLIFF DRIVE
COLUMBIA, S. C.

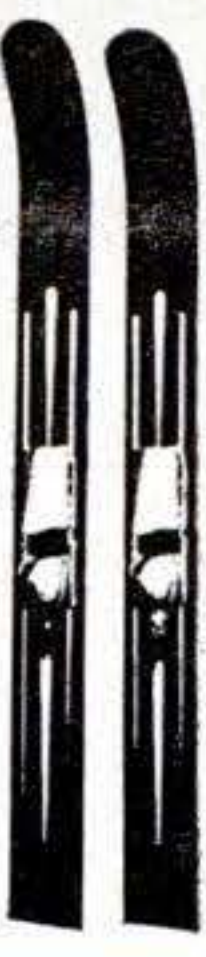

Secrets of VENTRILOQUISM Now Revealed!



Easy to learn in 60 to 90 days with our Home Study Course. **RESULTS GUARANTEED.** Make Money! Be Popular! Have Fun! Big Opportunity! Radio, Television, Stage Appearances! For Free Information regarding price and terms, WRITE. You must state your age. Dummy Catalog 25c.
MAHER HOME COURSE OF VENTRILOQUISM
Box 36, Studio PS-7; Kensington Station
Detroit 24, Michigan



... Swiss or American

Unique Sweazey System starts you making repairs right away. Develops your skill step-by-step. Teaches modern methods . . . professional short cuts. Learn by personal attendance or spare time home study. Free Sample Lesson. No obligation. Write today!

CHICAGO SCHOOL OF WATCHMAKING
2330 Milwaukee, Dept. 478, Chicago 47, Ill.

Would You Like to Make \$1,000 A MONTH?



That's what Stanley Hyman made selling the amazing new Presto Fire Extinguisher! Many others "cleaning up"—so can you! Amazing tiny new extinguisher ends fires fast as 2 seconds. **Guaranteed for 20 years!** Sells for only \$4.95. Write for Free sales kit.



Merlite Industries, Inc., Presto Div.,
114 E. 32nd St., Dept. P-16L, New York 16, N. Y.

CABINET MAKING



LOW COST HOME TRAINING COURSE FOR BEGINNERS & ADVANCED CRAFTSMEN
Make money. Learn skills and secrets of fine woodworking and tool use. Professionally prepared shop method training tells and shows how. Covers everything. Easy to master.

Write for Free Booklet
INTERSTATE TRAINING SERVICE
DEPT. F-2, PORTLAND 13, OREGON

TELEPHONES

and ALL SUPPLIES
Room to room, house to garage, private telephone service.

HANDSET CRADLE TELEPHONES (2) Complete outfit with 100' wire, battery, staples, diagram CD-2 \$17.25

WORM HARVESTER—Dan Mac Magneto — gathers fish-worms by electricity. Complete with instructions. \$6.50
FREE Illustrated booklet

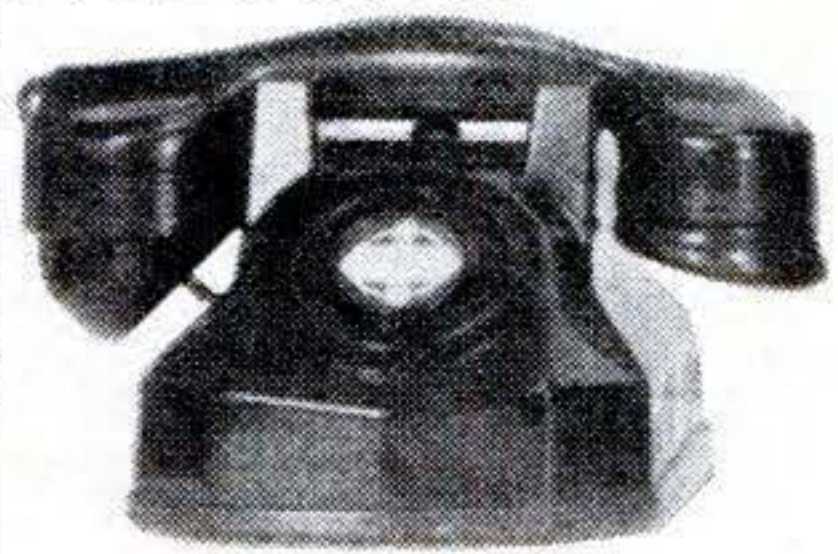

TELEPHONE REPAIR & SUPPLY CO. Dept. AA-208
1760 Lunt Ave., Chicago 26, Ill.

TELEVISION ELECTRONICS & RADIO

19 KITS OF EQUIPMENT, YOURS TO KEEP

NATIONAL SCHOOLS of Los Angeles, a leader since 1905, brings its famous training shop methods right into your home, in your spare time — gives you everything you need to make more money in a top-pay job. Course covers all phases of the industry including Color TV, Automation, AM-FM Radio, Hi-Fidelity, F.C.C. License. Many of our students open up their own TV-Radio repair shops. Easy to understand lessons, diagrams, manuals. Friendly personal guidance. Free graduate employment service. Low Tuition; earn as you learn.



AUTO MECHANICS & DIESEL

You are needed in auto garages, airplane factories, farm shops, experimental and government labs, wherever cars, engines, and trucks are repaired and serviced. National Schools Shop Method Training prepares you, in your own home, in your spare time for these fascinating opportunities. You get everything you need, including lessons, diagrams, manuals, consultation privileges, graduate employment service. Low tuition; pay as you learn.



YOU GET AND KEEP ALL THIS EQUIPMENT



Complete set of professional tools and tool box.



"Motor Analyzing Set" plus case and instructions.

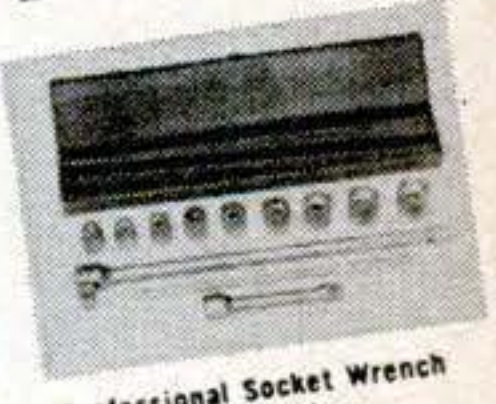

Professional Socket Wrench Set for all Engines.



NATIONAL SCHOOLS
Los Angeles 37, California

RESIDENT TRAINING ALSO AVAILABLE AT LOS ANGELES IN THESE 2 GREAT COURSES
If you wish to take your training in our famous Resident School Shops and Labs at Los Angeles, write for special Resident School folder



NATIONAL SCHOOLS
TECHNICAL TRADE TRAINING SINCE 1905
LOS ANGELES 37, CALIFORNIA

SEND COUPON TODAY!

NATIONAL SCHOOLS, DEPT. C-78
4000 S. Figueroa St., Los Angeles 37, Calif.

Please rush **FREE** Book and Sample Lesson checked below. No obligation, no salesman will call.

- "My Future in TV-Radio-Electronics"
- "My Future in Auto-Mechanics and Diesel"

Name _____ Age _____

Address _____

City _____ Zone _____ State _____

Check here if interested ONLY in Resident Training at Los Angeles.

No salesman will call!

PREPARE FOR BETTER JOB, BIGGER PAY IN SPARE TIME AT HOME

Today, choose the job you want—and prepare for it in time you might otherwise waste. Or if you are already in the work you like best, start training now for quicker promotion and increased pay. During the past 61 years AMERICAN SCHOOL has helped ambitious people to reach higher goals. Check subject that interests you and mail coupon for full information.

AMERICAN SCHOOL, Dept. GB46, Drexel at 58th, Chicago 37, Ill.

Without obligation, please send FREE and postpaid, full particulars about the subject checked below.

- | | | |
|--|---|---|
| <input type="checkbox"/> Accounting | <input type="checkbox"/> Contracting | <input type="checkbox"/> Mechanical Engineering |
| <input type="checkbox"/> Apprenticeship Courses | <input type="checkbox"/> Diesel Technician | <input type="checkbox"/> Mechanical Technology |
| <input type="checkbox"/> Architecture & Building | <input type="checkbox"/> Drafting—Building Trades | <input type="checkbox"/> Metalworking Courses |
| <input type="checkbox"/> Automotive Technician | <input type="checkbox"/> Drafting—Machine Trades | <input type="checkbox"/> Plumbing—Practical |
| <input type="checkbox"/> Better Foremanship | <input type="checkbox"/> Electrical Engineering | <input type="checkbox"/> Private Secretary |
| <input type="checkbox"/> Blueprint Reading | <input type="checkbox"/> Electricity—Practical | <input type="checkbox"/> Retail Merchandising |
| <input type="checkbox"/> Bookkeeping | <input type="checkbox"/> Electronics—Industrial | <input type="checkbox"/> Salesmanship—Outside |
| <input type="checkbox"/> Business Management | <input type="checkbox"/> HIGH SCHOOL COURSES | <input type="checkbox"/> Sheet Metal Work |
| <input type="checkbox"/> Civil Engineering | <input type="checkbox"/> Machinists | <input type="checkbox"/> Tool Making |

NAME..... OCCUPATION.....
HOME ADDRESS..... AGE.....
CITY..... STATE.....
Accredited Member NATIONAL HOME STUDY COUNCIL

MAIL COUPON NOW 

New Table Top Invention Puts You In... PROFITABLE RUBBER STAMP BUSINESS

Home Operators now make \$9.40 AN HOUR in business once monopolized by a few big companies

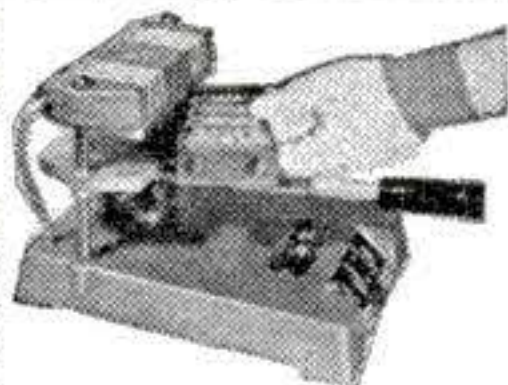

Special rubber stamps bring high prices—cost only pennies to make on new, low-cost table top machine. Take 27 cents worth of material, make perfect stamps, the kind businesses and offices now buy by the dozen at \$1.80 each. Make up to \$9.40 an hour. Start in spare time in your own home. Run machine on kitchen table using ordinary electrical outlet. Make any kind of stamp. We'll send you free information without obligation about this established, highly profitable business, now open to individuals for the first time. For free information send name today on a post card to Rubber Stamp Div., 1512 Jarvis Ave., Dept. R-3-H, Chicago 26, Ill.

AMAZING MUSIC DISCOVERY

PLAY ANY INSTRUMENT

—even if you don't know a single note now!



Now it's EASY to learn ANY INSTRUMENT—even if you don't know a single note now. No boring exercises. You play delightful pieces RIGHT AWAY—from very first lesson! Properly—by note. Simple as A-B-C. You make amazing progress—at home, in spare time, without teacher, same way TV Star Lawrence Welk did! FREE BOOK shows how easy it is to learn music this modern way. Write for it. No obligation; no salesman will call upon you. U.S. School of Music, Studio 157, Port Washington, N. Y. (60th successful year.)



GENUINE 360 POWER 3" REFLECTING TELESCOPE



COMPLETE WITH
50X, 120X, 150X, 360X
magnifications, 4X finder scope,
folding tripod, plus "Handbook
of Heavens" & Magic Star Finder

Only
\$26⁹⁵

Never before a precision reflecting telescope sold with all these features, for anywhere near this low price. Professional observations guaranteed with this powerful astronomical telescope. Equipped with special WIDE-ANGLE lens for observing satellites, stars, nebulae, comets, Saturn's rings, Jupiter, Mars, Moon's detail, other celestial phenomena with observatory clearness, amazing closeups guaranteed on all objects. Will "split" close double stars. Acclaimed by experts. Optically & scientifically correct, for serious astronomical work. Comes completely assembled ready to use. Eyepieces give full range of powers, 50X, 120X, 150X, 360X. 3 inch f12.5 mirror aluminized & overcoated, guaranteed to resolve to Dawes limit. Special ventilated aluminum mirror housing for use in all climates. 3 foot hardwood folding tripod. Equatorial, altazimuth mount compensates for earth's rotation & permits automatic tracking of astronomical objects. Takes long range photographs with ordinary box camera. 36" Bakelite phenolic tube. 4X finder scope sights targets fast. Completely portable; scope instantly removable from tripod for easy storage & carrying to remote areas. Also included with this amazing precision instrument, 270 page book "Handbook of the Heavens", Magic Star Finder. Satisfaction completely guaranteed or money refunded. Sent complete, nothing else to buy at the amazing low price of only \$26.95. Send cash, check, or money order. Shipped by express F.O.B. Shipping weight 10 lbs. Dept. DPS6. OPTIK INSTRUMENTS CO., 509 Fifth Ave., NY 17, N.Y.

HYDRAULIC JACK REPAIRS

Earn While You Learn at Home



Millions of jacks in gas & auto-service stations, truckers, body-shops, riggers, factories farms need servicing. We show you HOW—easy step by step directions—what tools to use. EARN UP TO \$5 an hour, in spare time, in your own basement or garage. Start your own business NOW. Write for folder No. PS-7 & free bonus offer.

Institute of Hydraulic Jack Repair

P.O. Box 50, Bloomfield, N. J.

STUDY TO BE A DOCTOR of Psychology or Metaphysics

Obtain a Ps.D., Ms.D., or Ph.D. Be a Teacher, Lecturer or Accredited Practitioner. Teach others how to achieve Health, Happiness and Contentment. Chartered by State. Correspondence courses only. Write for FREE book telling how.

THE NEOTARIAN FELLOWSHIP

Desk 5, Pickwick Building

Kansas City 6, Missouri

LEARN WHILE YOU SLEEP!



100 page fact-filled illustrated instruction book tells all. How to do it... what it costs... results obtained... plus hundreds of time-saving hints. Price \$2.00. Satisfaction guaranteed. Sleep-Learning Research Ass'n. Box 24-G, Olympia, Washington.

When Writing to Advertisers Please Mention Popular Science

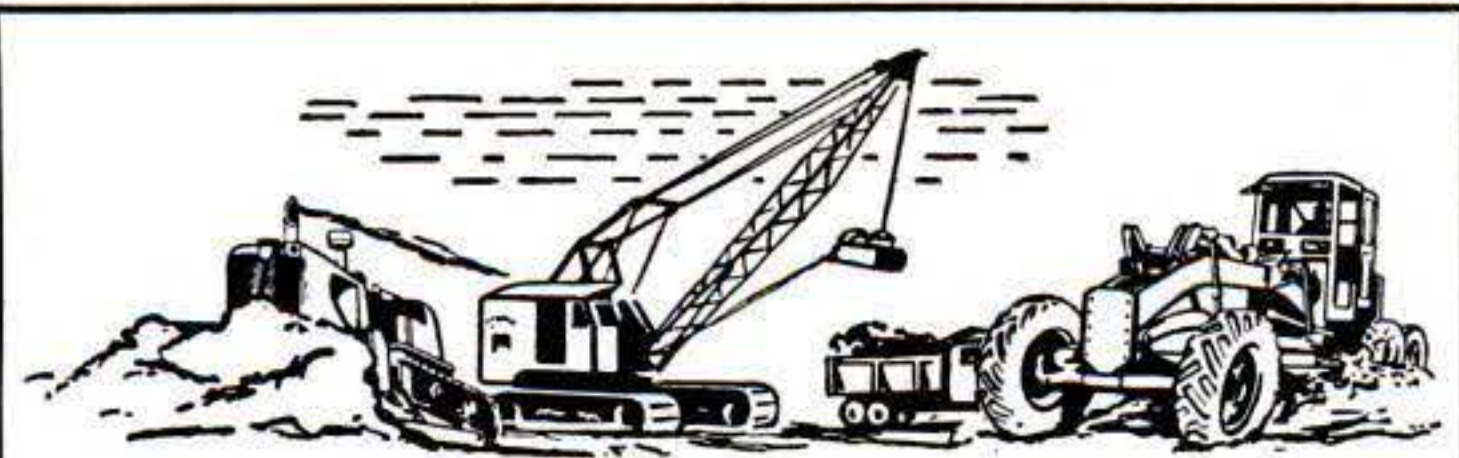

PLATE AUTO CHROME

MAKE MONEY - SAVE MONEY - PLATE ANY OBJECT IN HOME, SHOP OR GARAGE



NOW with our NEW PORTABLE SELF-POWERED ELECTROCHEMICAL Outfit. You can easily do your own plating. Not a paint. But a hard durable metal plate, equal to commercial plating. Get your own plating kit with instructions on plating metal and non-metal objects as Tools, Auto Parts, Silverware, Jewelry, Baby Shoes and 1001 other articles with Chrome, Nickel, Copper, Gold, etc. SEND NO MONEY. Everything sent C.O.D. for the low price of ONLY \$5.95 or send \$5.95 now and receive it postpaid. Money back in 7 days if not satisfied. M.Z. SALES CO., Dept. H-20, 113 West 42nd St., New York 36, N.Y.



HIGH WAGES!

Make big pay in the construction industry as an operator of Bulldozers, Draglines, Shovels, Back Hoes, Scrapers and Motor Graders. Learn these skills NOW! Machines of major manufacturers are used in our training program. Contractors need operators of earthmoving machines and pay high wages to our graduates. Don't be satisfied with just a job . . . learn a career!

VETERANS: Ask about G.I. Benefits

Write TODAY for FREE School Catalog, no obligation, to either address

**National School
of Heavy Equipment
Operation**

P.O. Box 8243, Dept. A-11
Charlotte, N. C.

**Western National School
of Heavy Equipment
Operation**

P.O. Box 527, Dept. A-11
Weiser, Idaho

SALE 16 X 50

REGULARLY \$69.50
SAVE \$44.51

High powered, whisper-weight (27 oz.!) Color corrected, Achromatic binoculars. 7" high! EZ to hold, EZ to focus. Instant finger-tip adjustment. Made in Japan. Hard Coated thru-out!
USE 30 DAYS. If not satisfied return for refund. Add \$1 postage, handling.

SALE PRICE ONLY
Including case and straps!
\$24.99

Add 10% Tax
UNITED BINOCULAR CO., 9043 S. Western, CRF-5016, Chicago 20. DEALERS WANTED



c.o.d.'s require \$2 deposit.

TAFT CRUISER KITS

DEPT. PS-758

FREE 40 pg. Color CATALOG
18 ft. Sedan Cruiser \$490.00 frt. inc.

All models 18 ft. cruisers... Big complete line of runabouts, fishing boats. NO WONDER WE'VE SOLD SO MANY!

TAFT MARINE WOODCRAFT
636 - 39th Ave. N.E., Minneapolis, Minn.

FIX OUTBOARD MOTORS POWERMOWERS, AND ALL SMALL 2 & 4-CYCLE GASOLINE ENGINES

MAKE EXTRA MONEY — or, repair your own equipment and SAVE! Fully illustrated, easy-to-understand, Home Study Course. Write today for FREE information.

LINCOLN TECHNICAL INSTITUTE
SUITE 7-G 472 MARKET STREET, NEWARK 5, N. J.

You can start a \$40⁰⁰ a Day Business



**In Your Spare Time!
Make Big Cash Profits
In Your Own Home...
Sharpening Household,
Garden and Shop Tools**

Turn spare time into Big Cash Profits with new Belsaw Sharp-All. No experience needed to sharpen knives, scissors, shears, ice skates, mower blades, hedge trimmers, axes, chisels and circular saws . . . Learn how easily you can start your own spare time business. Amazing low cost easy-payment plan. Send Postcard for **FREE BOOK.**
BELSAW SHARP-ALL CO 709 Field Bldg., Kansas City 11, Mo.

Now... 1/2 price!

METAL POCKET **ADDING MACHINE** IT ADDS, SUBTRACTS AND CALCULATES TO **ONE BILLION!**

1,000 TIMES HIGHER THAN OTHER MACHINES!

NOT \$3.95

SAVE 50%!

1.98

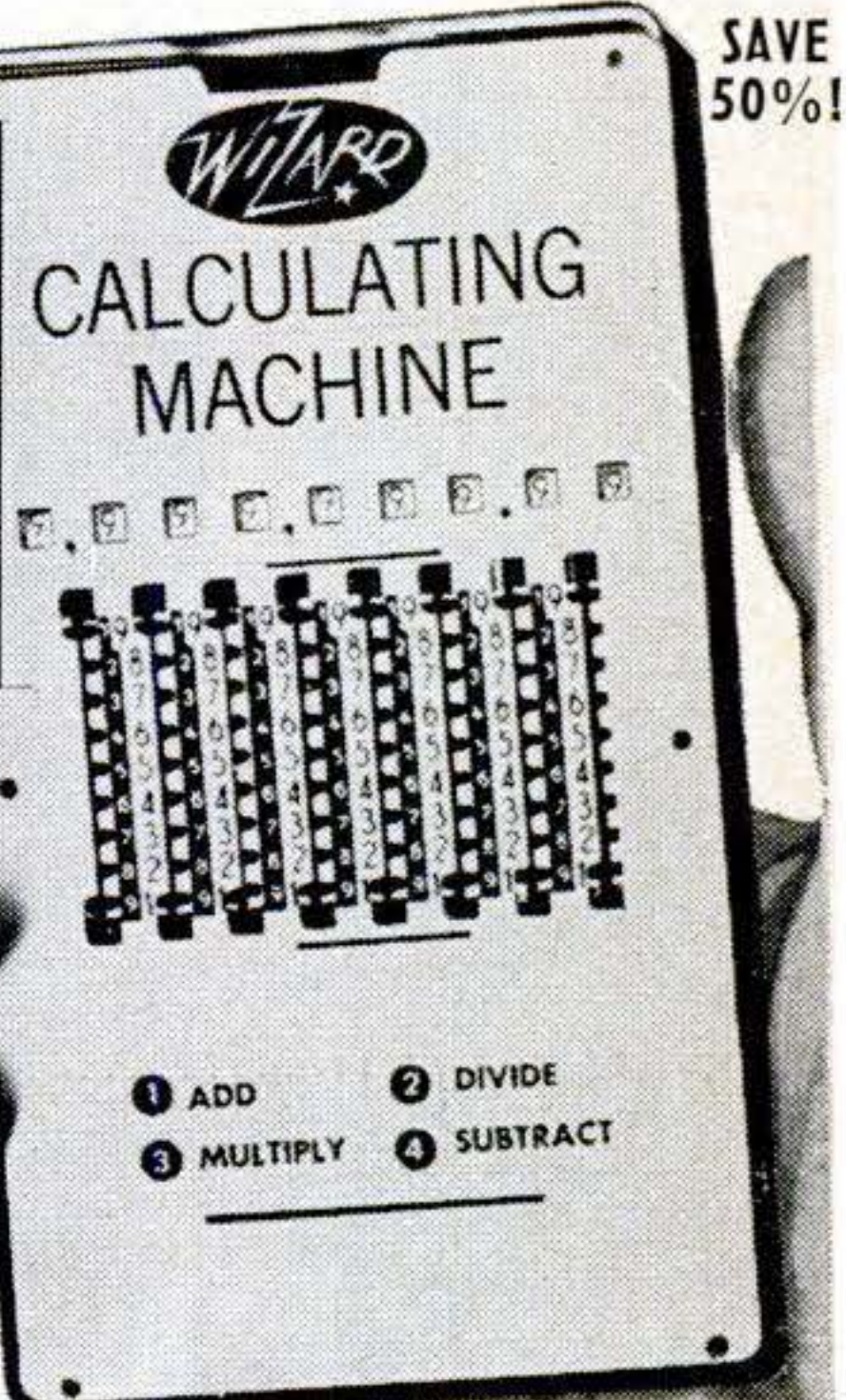

FREE HOME TRIAL!

- ★ Imported from West Germany
- ★ It Never Makes Mistake!
- ★ 10-YEAR REPLACEMENT GUARANTEE!

Just imported from West Germany—the finest superspeed AUTOMATIC Pocket Adding Machine in the world! New, metal Wizard Calculator—the only pocket machine that adds & subtracts, not only to one million but to ONE BILLION! Imagine—while others pay \$4.98 & \$3.98 for machines that add to 999,999, your Wizard Calculator adds to 999,999,999—almost ONE THOUSAND TIMES HIGHER! Yet you pay only HALF PRICE—just \$1.98 complete.

HOW IS THIS VALUE POSSIBLE? We are the world's biggest importers of binoculars, telescopes, etc. from W. Germany. We've given plants & factories abroad millions of dollars of business. No other mail order import house has contacts like us or buys like us. We import by BOATLOADS! (We ordered 200,000 adding machines for 1958 alone!). That's why only Thoresen can bring you this miracle half-price bargain!

Use machine to check bills, purchases; for income tax returns. Keep score of card games, golf, etc. Check children's homework in a flash! Just press numbers and see running total pop into view like cash register! Add mountains of figures with lightning speed! No guessing, no double-checking, no messy erasures, no starting all over, no costly human mistakes that may mean MONEY OUT OF YOUR POCKET! Use to multiply, divide, for decimal fractions, even dollars & cents! This machine is as accurate as \$150.00 office machine. It never makes a mistake! Unbreakable in normal use. Never needs repairs, adjustment or lubrication. No loose parts to fall out. Fits pocket or purse. Slim, sleek design. Other machines made of heavy cardboard, cheap plastic or flimsy tin. Wizard Calculator mechanism constructed of sturdy Korium STEEL! 10-year replacement guarantee! Geared for heavy-duty use. Clearing lever clears machine to zero in flash! Works smoothly and silently. Comes with stylus—READY TO USE!

TRY before you BUY! Enjoy 10-day home use FREE. Your money refunded if you don't agree this is the biggest value of its kind. Rush HALF-PRICE, FREE-TRIAL Coupon DIRECT to famous importer for prompt delivery anywhere in USA or Canada. THORESEN, Inc., Dept. 7-G-118, 585 Water Street, New York 2, N. Y.

MAIL 1/2 PRICE FREE-TRIAL COUPON NOW!

THORESEN, Inc., Dept. 7-G-118
585 Water Street, New York 2, N. Y.

RUSH amazing new Wizard Calculator on 10-day home trial. My money back if I'm not 100% satisfied.

- Reg. Model, \$1.98
- DeLuxe Executive Model in Genuine Vinyl Case of handsome MOROCCO-GRAIN, with built-in Memo Pad, ONLY \$2.98.
- Check, cash or money order enclosed. Send postage-paid.
- Send COD plus COD fee and postage

PRINT NAME _____
ADDRESS _____



SAVE DOLLARS at market. Keep running total of purchases. Machine helps you stop "impulse" buying of items you may not need. Keep within budget. Check-out counters are crowded. Mistakes may be made. Now you KNOW what your bill should be — BEFORE clerk punches single figure on cash register!

Train for Big Pay The ALLIED Way

Study AT HOME in Spare Time
or at Allied Institute, Chicago 5, Ill.

More Jobs than Graduates

Soon after starting many ALLIED students begin to make good extra money in their spare time. Students planning a career in engineering can begin their training in short courses at Home or at Allied Institute, and continue progressively toward an engineering degree in 31 months. ALLIED is approved by Industry, National Home Study Council, Dept. of Education, Office of Public Instruction, State of Illinois.

Mechanical Drafting
Structural Drafting
Aeronautical Drafting
Industrial Engineering
Tool & Die Designing
Auto Mechanics
Air Conditioning
Refrigeration
Tool & Die Making

SEND FOR
FREE
BOOKS

ALLIED INSTITUTE OF TECHNOLOGY,
1338-42 South Michigan Ave., Dept. PS-78, Chicago 5, Ill.

Send me without obligation information on your courses:

- | | |
|---|--|
| <input type="checkbox"/> MECHANICAL DRAFTING | <input type="checkbox"/> AUTO MECHANICS |
| <input type="checkbox"/> STRUCTURAL DRAFTING | <input type="checkbox"/> AIR CONDITIONING |
| <input type="checkbox"/> AERONAUTICAL DRAFTING | <input type="checkbox"/> REFRIGERATION |
| <input type="checkbox"/> INDUSTRIAL ENGINEERING | <input type="checkbox"/> TOOL & DIE MAKING |
| <input type="checkbox"/> TOOL & DIE DESIGNING | |
| <input type="checkbox"/> HOME STUDY | <input type="checkbox"/> RESIDENT |
| <input type="checkbox"/> VETERAN | <input type="checkbox"/> NON-VETERAN |

NAME.....AGE.....

ADDRESS.....

CITY.....COUNTY.....STATE.....

HOW TO GROW

ORCHIDS

AT HOME

"Most enjoyable hobby I know. People drove 100 miles to see this plant ... 10 flowers 8 1/2 inches across."
THOS. HURST, Utah

Learn Special Conditions of Light, Temperature & Humidity Needed!

WORLD'S MOST THRILLING HOBBY - PROFITABLE HOME BUSINESS. SUCCESSFUL HOME GROWER offers COMPLETE illustrated instructions. Tells HOW TO START. Explains everything you need to know about growing Cattleyas, Cymbidiums, Odontoglossums and others. Many Orchids GROW WITHOUT SOIL, get food from the air. Instructions include real BLOOMING-SIZE ORCHID PLANT. FREE - full details and 3-months Subscription to the "Orchidian," the "show-how" publication for home Orchid growers. WRITE TODAY! Airmail reaches us overnight.

TROPICAL FLOWERLAND, Dept. 27-A, 100 S. Vermont, Los Angeles 4, Cal.

FREE!
3-months
Subscription
to The
"Orchidian"



BE A CONSTRUCTION EQUIPMENT MECHANIC



Greer trains you to earn top pay. Complete Mechanics Course covering Diesel engine transmissions; torque converters; fuel injection systems; track assemblies; final drive assemblies; steering systems; idlers; rollers; power transfer systems; cable control systems; hydraulic control cylinders & welding pertaining to heavy equipment such as bulldozers, scrapers, loaders, off-highway trucks, etc. Course time—540 hours—10 weeks. Convenient payment plan. Write for details.

Please send FREE information

Name.....Age.....

Address.....Phone.....

City.....State.....



Greer TECHNICAL INSTITUTE
ATT. P. G. HUTCH, BOX 278, BRAIDWOOD, ILL.

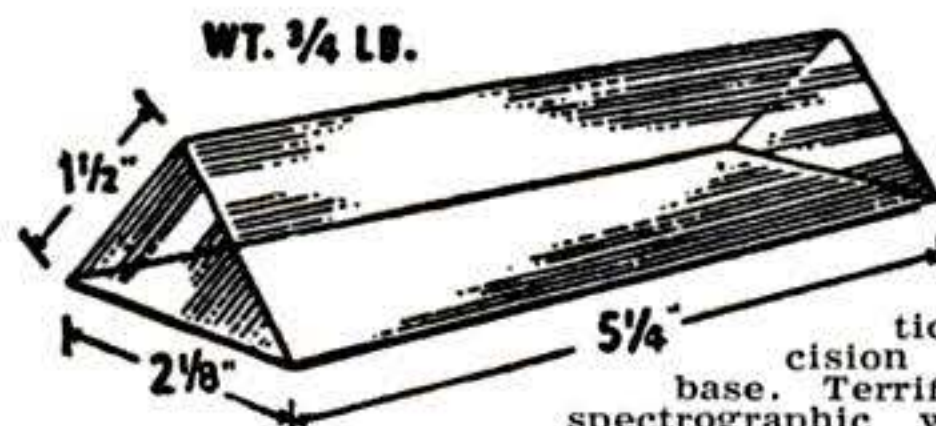

PRISMS
\$1.50

Made for U.S. govt. for tank periscopes. Fine optically ground, big precision prisms with silvered base. Terrific for all types of spectrographic work, in homemade telescopes & other optical systems for bending rays. Makes unusual paper weight (paint your name on it) or conversation piece for mantel. You'll find many other uses. NEW. PERFECT! Cost U. S. govt. \$25 ea. Now \$1.50 ea. or 4 for \$5.00. Same as above—1" long (no silver backing) \$1 ea. 5 for \$4. Postage paid on prepaid orders. Calif. res. add sales tax.

VOLUME SALES CO. 3930 Sunset Blvd., Dept. PS-758
War Assets Div., Los Angeles 29, Calif.

LAW FREE BOOK

THE LAW
TRAINED
MAN

Write today for a FREE copy of illustrated law book, "THE LAW-TRAINED MAN," which shows how to earn the professional Bachelor of Laws (LL.B.) degree through home study of the famous Blackstone Law Course. All necessary books and lessons provided. Moderate cost; convenient monthly terms. Write for FREE law training book today.

Blackstone School of Law, 307 N. Michigan Ave.
Founded 1890 Dept. 120-B, Chicago 1, Illinois

LEARN UPHOLSTERY

EARN MORE MONEY YOU'RE IN BUSINESS RIGHT OFF—Practical course, complete upholsterer's tools, materials, frames, all you need to earn while you learn AT HOME. N. Y. State-approved training in upholstery, slip covers, etc. Big Opportunity Field in good times and bad. FREE Illust. Catalog, FREE Sample Lesson. Write Today. Approved for Vets.

Upholstery Trades School, Dept. GL-1612, 721 Broadway, New York 3, N. Y.

RECESSIONS? LAYOFFS? not for LOCKSMITHS

LOCKSMITHING is not affected by recessions, layoffs or strikes. Get into this well paying, uncrowded field now. Learn from experts in spare time. Make money while learning. All special tools, equipment supplied. Low rates. Illustrated, easy lessons.

LOCKSMITHING INSTITUTE PS-103
150 Park Ave. East Rutherford, N. J.

SEND FOR
FREE
BOOKLET

SIGN PAINTING

Home-Study Course—Only \$5.95 Teaches you commercial sign painting and sign building as it is being done TODAY in leading shops all over the country. Complete practical course for self-instruction. Shows latest methods of truck lettering, office doors, wood letters, reflecting signs, plastics, sprayed signs, gold leaf, silk screen process, up-to-date alphabets, money-making business information, etc. **SATISFACTION GUARANTEED OR REFUND!** Contains all the instruction of a high-priced correspondence course. Full price, only \$5.95. postpaid. Or C.O.D. plus postage. No risk—order today. Satisfaction or money back! Order "Sign Painting Course."

NELSON-HALL CO., 210 S. Clinton St., Dept. 265-1, Chicago 6, Ill.

FREE A New Watch Crystal And 1 Year Guarantee with every Watch Repaired

Send That Broken Watch In Now for Expert Repair
Your watch cleaned, oiled. All for \$4.99
adj. All necessary parts replaced.
Self winding watches included. Prompt Service Guaranteed

Timers and Stop watches Extra, prices upon request. We reserve the right to return watches beyond repair.

Save COD charges. Send check or money order with watch to:
SIERRA WATCH REPAIRS 75 NE 195 St. North Miami, Fla.

TV DAN, THE
MUSCLE MAN



Send for
FREE
Catalog

GUARANTEES TO BUILD YOUR MUSCLES FAST!

IN 6 WEEKS OR MONEY BACK
You can have tremendous power, look bigger, have more confidence this tested way. Revolutionary new "Body Mold" courses builds your body in a way no other method can match. Get course FREE with order. Lowest factory price.
DAN LURIE BARBELLS
50 lb. set \$ 8.98 e 100 lb. set \$14.98
150 lb. set \$21.98 e 200 lb. set \$27.98
Extra wts - 14c per lb. 50% cash.
Balance C.O.D. FOB Plant
DAN LURIE BARBELL CO.
52 S-7 Bristol St., Dept. 870-G Bklyn 12, N. Y.

FREE! SEND FOR NEW SPORTS & HEALTH CATALOG

LEARN MEAT CUTTING

AT NATIONAL
Pay After Graduation



The steady dependable trade of Meat Cutting taught easily in 8 short weeks. YOU LEARN BY DOING under actual meat market conditions in big modern school at Toledo.

For beginners or men with experience. Get a profitable store of your own. Remember, PEOPLE MUST EAT! Big pay jobs. Free employment help. Thousands of successful graduates.

Buying, cutting, percentage, pricing, advertising, selling, etc. A complete retail meat education. National School established 35 years. Get National training NOW. Pay your tuition in easy weekly payments

after you graduate. Send coupon for FREE 52 page school catalog—TODAY. G.I. approved.

National School of Meat Cutting, Inc.
Dept. 51-F, Toledo 4, Ohio

Send me your FREE school catalog on National Training at Toledo in Meat Cutting, Meat Merchandising and Self Service Meats. No obligation. No salesman will call.

Name.....Age.....

Address.....

City.....State.....

Approved for training Korean Veterans

"YOU ARE UNDER ARREST!"

Help Bring Crooks to Justice Through Scientific
CRIME DETECTION!



We have taught thousands this exciting, profitable, pleasant profession. Let us teach you in your own home. Learn Finger Printing, Firearms Identification, Police Photography, Secret Service Methods thoroughly, quickly, at small cost. Over 800 of all American Bureaus of Identification employ I.A.S. students or graduates. Write for FREE "Blue Book of Crime."
(A Correspondence School Since 1916)

INSTITUTE OF APPLIED SCIENCE, 1920 Sunnyside Ave., Dept. 136B, Chicago 30, Ill.

EXCLUSIVE DOUBLE-BEARING HEAVY DUTY PUMPS



IRRIGATE • DRAIN • CIRCULATE • SPRAY
Use 1/4 HP motor or larger . . . 1 HP for up to 7,500 GPH;
1,000 GPH 60' high; or 3,000 GPH from 25' well. 1 1/4" inlet;
1" outlet. Stainless shaft. TYPE X—2 oil-less \$10.95
bronze bearings. Won't rust \$12.95
TYPE XB—Ball bearing model.
Best for belt drives.

Postpaid if cash with order.
Don't delay—send for yours today!
MONEY BACK GUARANTEE

Centrifugal and Gear Pumps in All Sizes
LABAWCO PUMPS, Belle Mead 4, N. J.

ENGINEERING

DEGREE IN
27 MONTHS

B.S. DEGREE IN

AERONAUTICAL, CHEMICAL, CIVIL, ELECTRICAL, MECHANICAL and ELECTRONIC ENGINEERING (Inc. Radio and TV)

Also B.S. DEGREE in 36 mo. in Mathematics, Chemistry, Physics (including Nuclear Physics). Engineering Science preparatory courses. Thorough, practical program. Individualized instruction emphasized. Government approved for G. I.'s

Keeping pace with progress in science and engineering

Spacious campus. 20 buildings; dormitories, gymnasium. Playing field. Modern, well-equipped laboratories including new physics lab and wind tunnel. Low tuition. New terms start quarterly. Enter September, December, March, June. Big demand for graduates. Students from 48 states and 40 foreign countries. Many earn a major part of their college expenses in this large industrial center. Send coupon for free catalog and full information. Enroll now!

INDIANA TECHNICAL COLLEGE

678 E. Washington Boulevard, Fort Wayne 2, Indiana

Please send me free information on 27 Mo. B.S. DEGREES in:
Aeronautical Chemical Civil Electrical
Mechanical Electronics

on 36 MONTH B.S. DEGREES in:
Mathematics Chemistry Physics

Name.....

Address.....

ELECTRONICS • RADIO-TV • COMPUTERS



At this pioneer school of technology, you can earn an A.A.S. degree (2 yrs) or a B.S. degree (4 yrs) in preparation for a successful career as an engineering technician or engineer. Scholarships, part-time work, job placement help available. Write for FREE career booklet. Give age and course preference.

MILWAUKEE SCHOOL OF ENGINEERING
PS 758, 1025 N. Milwaukee Street, Milwaukee, Wisconsin

free

**ALLIED'S Big Value
ELECTRONIC SUPPLY
BARGAIN SUPPLEMENT**
send for it!



BIGGEST VALUES EVER:
Biggest savings ever!
Send for your FREE copy today.

SAVE MOST ON HI-FI, KITS,
EVERYTHING IN ELECTRONICS

Send for our latest Supplement packed with bargains and new products! Top buys in famous KNIGHT-KITS, new Hi-Fi systems and components, stereo, recorders, amateur gear, P.A. systems, test equipment, TV accessories, electronic parts, tubes and tools. Save as never before!

ALLIED RADIO

ALLIED RADIO CORP., Dept. 7-G8
100 N. Western Ave., Chicago 80, Ill.

FREE

Send FREE ALLIED Supplement No. 175

Name.....

Address.....

City.....Zone.....State.....

WORLD'S GREATEST

CLASSIFIED

OPPORTUNITIES

Here are hundreds of opportunities offered especially to the readers of Popular Science Monthly. Read them. Answer them! You can make and save money.



POPULAR SCIENCE MONTHLY — 353 FOURTH AVE. — NEW YORK CITY 10

Classified Ads only \$1.10 per word insertion, payable in advance. Minimum ad 10 words. To be included in September issue, copy should be in our office by July 24. No cancellations accepted after July 15. Address orders to O. K. Kelly, Classified Adv. Mgr.

1 AUTOMOBILES & MIDGET CARS

CROSLY And Foreign Car Owners Catalogues Available Parts Discount. Box 7, Elmont, New York.

BOYS power driven auto. Build your own. Plans. Parts List, 35 cents. Sypher Co., Station F, Toledo, Ohio.

NON-profit organization offers automobile literature—old, modern and foreign; dealer books, service manuals, glossy photographs, free motor magazines. Write to get on free mailing list. Auto Maniacs, Inc., Stockbridge, Mich.

OLD copies of Popular Science wanted—any issue from period 1890 to 1915. Condition not too important provided books are complete with no pages removed. Write to Box No. 308, Tuckahoe, New York.

2 AUTO SUPPLIES & EQUIPMENT

SAVE money on Jeep and army truck parts. Large inventory. Catalogs for Jeep and G.M.C owners. American Auto Parts Co., 1830-PS Locust, Kansas City, Missouri.

FREE! 1953 Automotive Catalog. 260 pages—75,000 items. Parts of every description for stock cars, hot rods, custom cars, trucks, and station wagons. Save up to 50%. Same day service. Quality guaranteed or money back. Send 25c (refundable, first order). J. C. Whitney, 1919 PS-7, Archer, Chicago 16, Ill.

FREE Giant Auto Parts Catalog. Thousands Scarce Accessories Stores Don't Have. Gadgets, Custom Equipment. Send 25c Postage (Refundable). Newhouse Automotive Industries, 5805-PS-7 Beverly, Los Angeles 22, Calif

FREE polishing mitten, impregnated activated cleaner combined waterproof paste wax. Double surface, no rubbing. Send 25c (refundable first order) with accessory catalog. Auto, 156F West 86 Street, NYC.

TRAFFIC signal finder magnetic mounting \$1.25 each. \$2.00 per pair. N.W.S., P. O. Box 954, Sandusky, Ohio.

RING-Valve Job while driving, \$6.00. Literature. Motaloy, Grantham 27, Pa.

JEEP Owners—V-8 power read Jeep owners ad. Page 201.

GEN-Exc. Keeps voltage regulators working. Scientific Electric Co., Box 12, Wickliffe, Ohio.

ENGINES, Chevrolet, Ford, Oldsmobile, Etc. 1955, 1958 near new. Reasonably priced. Suitable Marine Conversion. Ledbetter Enterprises, 1015 West 17th, Texarkana 8, Texas.

POWERSCAN—Power rear view mirror, eliminates blind spot. Free circulars. Gim Industries, Dept. P, 707 Whittier Street, Cincinnati 29, Ohio.

CHARGE automobile batteries using parts from average home workshop. Instructions \$1.00. Charger, Box 743, Harrisburg, Pennsylvania.

DUAL Auxiliary Accelerator Left Foot Gas Pedal. \$6.95. Lehner Company, Ness City, Kansas.

AUTO-Bed Conversion Kits with complete instructions. Works on all two and four door sedans, club coupes, station wagons and convertibles. Reclines back of front seat, making a complete bed in your car when needed. Only \$19.95. Send cash, check or money order, along with make and model of car. Auto-Bed Company, Reidsville, Georgia.

USE THIS HANDY INDEX TO FIND WHAT YOU WANT

Advertising, Agencies for Advertisers . . .	53
Agents Wanted	43
Air Conditioning	7A
Antique, Relics & Indian Goods	29
Artists Supplies	76
Astronautics	5A
Authors Service	52
Auto Supplies & Equipment	2
Auto Trailers	3
Automobiles & Midget Cars	1
Aviation	5
Batteries, Generators, Etc.	6
Boats, Outboard Motors	11
Body-Building Courses, Jiu Jitsu, Etc.	12
Books & Magazines	23
Business Opportunities	37
Business Service, Information, Name Lists	50
Buy It Wholesale	38A
Cameras, Photo Supplies	34
Camping Equipment & Tents	16
Cartooning, Sign Painting, Chalk Talks	54
Chemistry & Physics	41
Coins & Currency	26
Color Photo Finishing	32A
Contests	46
Detectives	47
Do-It-Yourself	66
Dogs, Birds, Hamsters & Pets	17
Educational & Instruction	45
Electrical Supplies & Equipment	7
Enamels, Paints & Varnishes	64A
Engines, Motors, Etc.	10
Farm Machinery	10A
Farms, Other Real Estate	19
Field Glasses, Telescopes	14
For Inventors	60
For Sale Miscellaneous	71
For the Home	69
Formulas, Plans, Etc.	39
Frog Raising	18A
Games & Toys	24A
Geiger Counters, Treasure Finders	77
Help Wanted	42
High-grade Salesmen	44
Hobbies, Collections	31
Home Craftsman	65
Hypnotism	24
Inventions Wanted	61
Language Outfits	48
Live Bait	18
Machinery, Tool Supplies, Etc.	9
Mag'c Tricks, Puzzles, Etc.	25
Manufacturing	63
Minerals & Precious Stones	30
Miniatures	31A
Miscellaneous	79
Models, Model Supplies	64
Moneymaking Opportunities	38
Motion Pictures, Slides, Sound Equip.	33
Motorcycles, Bicycles & Supplies	4
Music, Song Writers & Records	35
Of Interest To Women	70
Old Gold, Jewelry, Watches	67
Old Stamps Wanted	27
Patent Attorneys	59
Patents For Sale	62
Personal	80
Photo Finishing, Photocopies, Etc.	32
Plastics	40
Plays, Stories, Etc.	49
Poultry & Supplies	21
Printing, Multigraphing, Etc.	57
Printing Outfits, Supplies	58
Profitable Occupations	22
Radio, TV, Supplies & Equipment	36
Razor Blades, Shavers	74
Rubber Stamps & Office Supplies	56
Special Services	51
Sporting Goods, Guns, Fishing Tackle, Etc.	15
Stamp Collecting	28
Tattooing Supplies	75
Tobacco & Pipes	68
Trees, Shrubs, Roots & Herbs	20
Trigonometers	9A
Typewriters & Office Machines	55
Wanted to Buy	72
Watch Repairing	78
Wearing Apparel	73
Welding, Soldering	8
Western Merchandise	79A
Wheels, Axles, Hand Trucks	10B

3 AUTO TRAILERS

TRAILER axles with Truck wheels; Electric brakes; Springs \$100.00. Tandem \$200.00. Broadway Trailers, No. Branch, New Jersey.

BUILD Utility Trailer from old auto front end—steel or wood frame. No welding. Profits, Photos, Both Plans \$1.00. Uniform Trailer Service, Box 620, Ithaca, N. Y.

BUILD Expanding eight foot trailer. Accommodates five. Literature 10c. Framar Company, Wilmington, Massachusetts.

PICKUP coaches. Trailer blueprints. Literature 10c. Comstock Trailers, Parsons, Kansas.

4 MOTORCYCLES, BICYCLES AND SUPPLIES

RECONDITIONED Motorcycles and motors, Chromium accessories. Complete stock Indian parts. Expert rebuilding. Fast service. Indian Motorcycle Sales, Kansas City 27, Missouri.

DOODLEBUG motorscooter \$10, Indian \$17, Fiberglass Sport Car \$75, less engines. Whizzer engine \$3, Harley \$10. Crosley Pickup \$60. (mailorder only). Send 25c (35c for first class mailing) for Directory-Catalogue Number 84, listing these and Hundreds of other bargains in midget cars, motorscooters, homebuilders parts, plans, etc. Midget Motors Directory, Athens, Ohio.

MOTORSCOOTER \$6.00; Indian Motorcycle \$30.00; Whizzer \$7.50; Briggs (Kick Starter) \$12.75. Send 25c (35c first class mail) for catalog #32 jammed with sensational bargains in motors, motorscooters, midget cars, motorbikes, construction plans. Gall, 1313 Jefferson, Toledo, Ohio.

5 AVIATION

BOOKS, aviation. Free catalog. Aero Publishers, 2162-PS7 Sunset, Los Angeles 26, California.

HELICOPTER Mechanics Urgently needed. Train at home. Write—Southern Cross Helicopter Institute, 378A Baldwin, Jersey City 6, N.J.

HOMEBUILT Helicopter Handbook \$1.00. Homebuilt Helicopter Directory \$1.00. Urshan, Box 4332 N.P. Station, San Diego 4, California.

BUILD flying platform. Components description, Three scale drawings; \$2.00. Shelby Industries, Box 573C, Bellflower, California.

PROPELLERS, plans, supplies for airboats and snowplows. Latest designs, prompt delivery. Catalog 25c. Banks-Maxwell, Box 3301G, Ft. Worth 5, Texas.

TAIL rotor kits. Blades for homebuilders. Pictures, Specs., Prices, 50c. Adams, Box 6042-D, Lakewood, California.

5A ASTRONAUTICS

ROCKETS—Complete plans, 1 & 2 stage, 3/4" to 3 1/2" diameter. See ad page 47.

6 BATTERIES, GENERATORS, ETC.

EDISON Nickel Storage Batteries. Any voltage, any amperage. Unconditionally guaranteed. Power Plants, Generators, Motors, Literature. Hawley Smith Co., Croton Falls 2, New York.

7 ELECTRICAL SUPPLIES & EQUIPMENT

BOOK 200 electric stunts \$1.00. Cuttingson, 26278 Arastradero, Los Altos, California.

CHECK Volts? Combination Voltage Tester/Automatic Pencil Checks 80-550 V AC/DC. Pocket-size. Many uses. \$1.00 postpaid. Empire Elec. Industries Corp., Box 11, Bethpage, New York.

CIRCUIT breakers—many uses for this device. 5 for \$1.00. Box 332, Salem, Mass.

ELECTRICIANS! Bend conduit easily, correctly. New "Simplified System" \$3.00, literature free. Wm. Goforth, Box 455A, Clarksville, Tennessee.

8 WELDING, SOLDERING

NEW All-in-one oxyacetylene outfit welds sheet, plate; cuts heavy steel; heats; brazes. Uses interchangeable tips. Portable, easy to operate. Complete with instructions, \$84.50. Gas Cylinders on special moneysaving plan. Write for free information: Dept. S, Linde Company, 30 East 42nd Street, New York 17, New York

WELDERS, 110/220. Welds 1/2". \$39.50. Morris, 1070 Inner Drive, Schenectady, New York.

ACETYLENE Welding Outfits new \$54.50; Arcwelders \$56.50; Eagle Welding, Dept. 42, 5085 Broadway, Chicago 40, Ill.

FREE factory catalog. Welder kits, supplies. Build 350 Ampere Welder From Aircraft Generator. Plan 10c. LeJay Manufacturing, Minneapolis, Minnesota.

9 MACHINERY, TOOL SUPPLIES, ETC.

OIL Drum Cement Mixer Assembly Kit. Circular. Nu-Way-Do Co., Newaygo, Michigan.

PREGROUND tool bits, other tools. Free List. Tool-Craft Co., C1, Coudersport, Pa.

9A TRIGONOMETERS

ENGINEERS. Draftsmen, Students: Triangulator Makes Trigonometry Easy. \$1.25. No C.O.D. Trical, Box 67, Buffalo 15, New York.

10 ENGINES, MOTORS, ETC.

DIESEL Injector Parts Wanted GM51-71-110. Mayer, 7120 Carnegie, Cleveland 3, Ohio.

REWIND Motors yourself. Complete instructions \$1.00. Lewis Mfg., Howell 11, Michigan.

GAS engines: Briggs Stratton: 2-2 1/4 H.P.: Brand new: Recoil: Horizontal or Verticle shaft: Were priced \$64.80: Our special price \$39.95—Freight paid: Money back guarantee. (Details Free). Northern, 172-S Merrimac Street, Boston 14, Mass.

10A FARM MACHINERY

SENSATIONAL Garden Tractor. Hoes between plants and rows, including strawberries. Eliminates hand hoeing. Nothing else like this. Patent 2742840. Also tills. Fantastic offer to first few inquiries. Auto Hoe. DePere 69, Wisconsin.

11 BOATS, OUTBOARD MOTORS

NEW, used, rebuilt marine motors. Marine conversions, fittings. Free Catalog. Stokes Marine Supply, Dept. 23, Coldwater, Mich.

FREE big catalog; Boat Kits save 1/2 to 2/3 "factory built" prices. 8' through 13' outboards designed for amateur assembly. Trailers, Fiberglass, Hardware, Accessories. Luger, Dept. K-7, 9200 Access Rd., Minneapolis 20, Minnesota.

FULL size, cut-to-shape boat patterns, blueprints, 7 1/2-38 feet. Big new 88 pg. illustrated "Build a Boat" Catalog of Naval architect-designed Cruisers, Runabouts, Skiffs, Outboard Boats, Sailing, Racing, Houseboats, 50c. "How to Build a Boat" Booklet, \$2.50. Hardware & Equipment Catalog, \$2.00. Cleveland Boat Blueprint Co., Dept. A-77, Box 1651, Cleveland, Ohio.

BOAT Plans—Full Size Patterns—Frame Kits. Modern Inboards and Outboards for amateur builders. Complete New Catalog 50c or specify requirements. New Speedboat Inboard Hardware Catalog 25c. Glen Marine, 9152 Rosecrans, Bellflower, Calif.

MARINE conversions. Ford, Chevrolet V8, Jeep engines. Catalog 25c. Lehman Manufacturing Co., 972A Broad St., Newark 2, N.J.

FIVE horsepower Clinton outboards, 1958 models, cruise tank, reverse, \$99.95. Bobs Motor Service, Blissfield, Michigan.

FIBERGLAS boat covering. Free literature and samples. Wholesale prices. Seifert's, Box 31X, DePere, Wis.

WATER ski kit. Terrific savings. Top quality ash. See our ad page 33.

FIBERGLASS Top Marine Grade. By Yard or kit. Ontario Fiberglass Co., Box B, East Rochester, New York.

FIBERGLAS repair kits, for permanent patching on boats, cars, furniture, etc. Kits at \$4.98, \$2.00, sample kit \$1.00—Sent postpaid, no C.O.D. Royal Fiberglass, 19711 St. Marys, Detroit 35, Mich.

12 BODY-BUILDING COURSES, JIU JITSU & ATHLETIC EQUIPMENT

BUILD powerful arms, chest, shoulders! 22 exercises, \$1. Fonsad, Box 601-C, 1100 Market, Wilmington 99, Delaware.

FREE muscle building information. Bodytone, Box .38A, North Miami, Florida.

GAIN solid bodyweight this summer! Sound dietetic program works wonders on problem thin men. Guaranteed. Send \$1.00 to W. Snyder, 6904 Henley St., Phila. 19, Pa.

DANCE illustrated instruction book mailed in plain wrapping. Calco, Box 267, Station "F", Milwaukee 9, Wisconsin. \$2.98.

NEW body—health—strength—muscles—gain—reduce. Any age. Easy! Amazing guaranteed discovery uses only a rope! Free details. Roperise, 4834 Art, Studio 2-A, San Diego 15, Calif.

DEADLY oriental fighting art, power that splits planks, masonry barehanded. Profusely illustrated training manual \$3.98. J. Yim Lee, 584 Valle Vista Ave., Oakland 10, Calif.

BARBELLS, Dumbbells, Exercise equipment Courses. Free booklet. Good Barbell Co., Siloam Springs, Ark

PUSHED around? Don't take nonsense from bullies. Surprise them. Easy when you know Police Jiu Jitsu. Complete fully illustrated course in one volume as taught police and armed forces. Send \$1 now. Satisfaction guaranteed. Books Publishing Co., Amityville 39, New York.

BARBELLS, Exercise Equipment, Courses Booklet, Souvenir Photos 25c. Reading Barbell Co., Reading, Pennsylvania.

14 FIELD GLASSES, TELESCOPES

BUILD your own Reflector Telescopes. Complete kit; Mirrors, Eyepieces, Tripods, all other accessories. Request free illustrated literature. Criterion Manufacturing, Dept. KP-45, Hartford, Connecticut.

FREE Catalogue! Thousands war surplus optical bargains. Lenses, Prisms, Telescopes, Binoculars, etc. Send \$1.00 for 10 Lens Hobbyist Set and Project booklet. G. Jaegers, 691 West Merrick Road, Lynbrook, New York.

WAR Surplus bargains! Millions of lenses, instruments, telescopes, binoculars, components and complete line of astronomical telescope items. World's greatest optical market place! Send only \$1.00 for beginner's 10-lens kit and big instruction booklet Stock 2-CN. Write for catalog-CN Free. Edmund Scientific Co., Barrington, New Jersey.

AMAZING prices, precision binoculars, Folder "Binocular Selecting," catalog free. Dealers also write. Prentiss Importers, Mercury Bldg., West Los Angeles 25, Calif.

BINOCULARS, telescopes, microscopes. Terrific values \$3.98 up. Request free money-saving catalog. Criterion, Dept. S-68, Hartford, Connecticut.

REFLECTOR Telescope Kits \$7.25 (3") to \$175.00 (12"). Mirrors, cells, Focusing Mounts, Tripods, Eye Systems. Anything, everything in telescopes. Optics—Also Binoculars, Microscopes, Optical Gadgets. Free Catalog. Also Ready to use telescopes from \$25.00. Esco Products, Oakridge, N.J.

REFLECTING Telescope completely assembled. 60X. \$29.75. Guaranteed Observatory clearness. Free information. The Skyscope Co., P. O. Box 55, Brooklyn 28, New York.

ASTRONOMICAL Books, Star-Atlases, free list. Herbert Luft, 69-11 229th Street, Bayside 64, New York.

DYNASCOPE—Sensational New Reflector Telescope. Send for details. Criterion Company, Dept. DS-51, Hartford, Connecticut.

REFRACTOR and reflector telescopes. Also telescope kits and supplies. Free illustrated catalog. Suffolk Science, Mattituck, N. Y.

15 SPORTING GOODS, GUNS, FISHING TACKLE, ARCHERY TRAPPING

BEAD-Lure Casting Spoon. Catches pike, bass. 90c. 2—\$1.50. Tibbetts Baits, 502—18th Ave., Menomonie, Wisconsin.

OLD Colts. Many others, New stocks Popular Antique Revolvers. Win. Rifles Frontier Colt Parts Long List 25c. Laredo Gun Shop, 3110 San Bernardo, Laredo, Texas.

10,000 GUN bargains!!! Kentuckies—Colts—Lugers—Mausers—Hunting guns!!! Armour—Swords—Catalog 50c. Agramonte's, Yonkers 2-A, New York.

5,000 BARGAINS, firearms, binoculars, war relics, catalog 50c. Smith Museum, Runnemed, N. J

FISHERMAN! buy a rap-a-rod and rap it yourself, \$6.50 plus postage. B-C Company, 9045 16th S.W., Seattle, Washington.

154 PAGE catalog—a real "Dream Book" for fishermen! It's free! Netcraft Company, Dept. A7, Toledo 13, Ohio

JAP rifles altering American shells \$6.00. Jap shells \$3.95, catalog 5c. TP Shop, West Branch 10, Michigan.

MOLDS for Fisherman's Sinkers. Jigs, Squids, Casting and Spinning Lures. Free Catalogue. Sweet's Molds, Tonawanda 3, New York.

100,000 PRODUCTS Wholesale—Free catalog! Send postcard: Econ-O-Mart, Whippany 16, New Jersey.

16 CAMPING EQUIPMENT & TENTS

TENTS, direct from manufacturer; world's largest selection. Low prices. Send 25c (print name-address) for 160 page complete catalogue of Tents, Camping Equipment, National Camp Sites guide & Camping handbook. Morsan, 10-15G 50th Avenue, Long Island City 1, New York.

DON'T buy anything until you've seen the "New Look" in camping. New camp trailer, a new cartop camper, new camp kitchen. Free illustrated brochure. Write: Hellite Trailers, Inc., Dept. P.S., Lodi, California.

17 DOGS, BIRDS, HAMSTERS, RABBITS & PETS

HAMSTERS—Golden; Young, \$3.00 pair, breeders, \$4.00 pair. New mutation, \$5.00 pair. Adirondack Hamstery, Prospect 23-U, New York.

RAISE rabbits on \$500 month plan. Plenty markets. Free details. White's Rabbitry, Delaware, Ohio.

MAKE Big Money Raising Nutria, Chinchillas, Cavies, Mink, Rabbits, or Pigeons for us. Free information. Keeney Brothers, New Freedom, Pennsylvania.

WE Pay \$3.50 lb. dried. Grow Mushrooms. Cellar, shed and outdoors. Spare, full time, year round. We have 25,000 customers. Free Book. Washington Mushroom Ind., Dept. 177, 2954 Admiral Way, Seattle, Wash

EARN \$10,000 Yearly Raising Angora Rabbit Wool for Us. Information 25c Coin. American Angora Company, Malta 1, Montana.

18 LIVE BAIT

\$10,000 YEAR possible, earthworms. 32 Page booklet tells how 40c. Missouri Earthworm Research, Box C-6851, Kansas City, Missouri.

NEW Soilless Method—Raising Night-crawlers, Red Worms. Three Oaks Ranch, Dresden, Tenn

AFRICAN Giant Redworms, 100—\$2.00 (Dealers quoted). Ozark Worm Farm-V. Willow Springs, Missouri.

19 FARMS, OTHER REAL ESTATE

FLORIDA—Nice homesites, \$345 at \$10 monthly. Folder Free. Winfree Vernor, DeLand, Florida.

STROUT Catalog—Free! 3,186 Bargains, 34 States, Coast-to-Coast. Farms, Homes, Businesses. World's Largest! 58 Years Service. Strout Realty, 251-ZB 4th Ave., New York 10, N. Y.

CANADIAN Lands: \$10 month buys 20 acres. Cottage sites, hunting, fishing camps. Free information. Land Sales Corporation, 130 Shaftesbury, Downsview, Ontario, Canada.

20 TREES, SHRUBS ROOTS, HERBS

RAISE live ming trees! Revolutionary method! No special tools. \$2.00. Details free. Crockford, 2479 N.W. 97 Street, Miami 47, Florida.

22 PROFITABLE OCCUPATIONS

\$5000 FROM Half Acre growing Ginseng, crop bought. Particulars 10c. Associated Growers, Sperling, Manitoba.

SAVE Money! Buy Wholesale! Free Catalog General Merchandise. Norris, 487-H Broadway, New York.

FREE Picture Folder, "How to Make \$3,000.00 Yearly Sparetime, Backyard, Raising Earthworms!" Oakhaven-7, Cedar Hill, Texas.

MAKE Money Selling Recipes and Household Hints by Mail. Information Free. Barrett, Dept. CA-28, 7464 No. Clark, Chicago 26.

TREE-mushroom pioneers! Spawn, Instructions, \$1.00. Ohga, PS117, Sigakenkusatu, Japan.

BUY Wholesale! 25,000 Nationally Advertised Products. Get Amazing Dealer Catalogs. Complete Details Free. American Wholesalers, 1841-F Levee, Dallas 7, Texas.

INVESTIGATE Accidents—Earn \$125 week to start. Claim Investigators are urgently needed to investigate more than 490,000 accidents daily. Work full time for insurance company, railroad, steamship line, or government office. Or step into your own profitable spare time business. No experience needed. Free book—Now! Universal Schools, B-7, Box 8202, Dallas 5, Texas.

BECOME independent with your own franchise business. Thousands earning handsome incomes. Request interesting facts today. National Franchise Reports, PS-528, 333 North Michigan, Chicago 1.

FREE Literature—Make Big Money Raising Fishworms and Crickets. Carter Farm-10, Plains, Ga.

WHOLESALE! Nationally advertised merchandise. Fabulous profits, savings. Write: Wholesale Buyers, 111 Meramec, St. Louis 5-SA, Mo.

FREE Book "990 Successful, Little-Known Businesses." Work home. Plymouth, 1610A 43rd Street, Brooklyn 4, New York.

WE Pay \$3.50 lb. dried. Grow Mushrooms. Cellar, shed and outdoors. Spare, full time, year round. We have 25,000 customers. Free Book. Washington Mushroom Ind., Dept. 101, 2954 Admiral Way, Seattle, Wash.

MUSHROOMS Quicker, Easier, Cheaper. Newest Facts Free. Spawn \$1.00. Luxorco, 641 South 19th, Newark 3, N. J.

EARN big profits! Import without capital! United Wholesalers, 1265-KK Broadway, New York 1, N. Y.

\$6,000 FOR Mister, Mrs.: \$3,500! Free "Secret Journal" Plan. Magical! Work home! Publico-N44, Oceanside, Calif.

FREE Book "505 Odd, Successful Businesses." Work home! Pacific-37C, Oceanside, Calif.

VENDING Machines—No Selling. Operate A Route of Coin Machines And Earn Amazing Profits. 32-Page Catalog Free. Parkway Machine Corporation, Dept. 17, 715 Ensor Street, Baltimore 2, Maryland.

23 BOOKS & MAGAZINES

BRITISH Book Bargains. Any subject. Catalog free. Transbooks, Box 1-PTE, Wantagh, New York.

GOOD Used Books, 50c-\$1. Free Lists. Editions, Dept. PS, Hempstead, New York.

ATHEIST Books. Catalogue free. Truth Seeker Co., 38 Park Row, New York 8.

BOOKHUNTERS: All Subjects. Send Wants! Jaher Book Service, 183 Hazelwood Drive, Westbury, New York.

NATIONAL Geographic Magazines 1888-1952. Any issue. Periodical Service, Box 465-PS, Wilmington, Delaware.

BOOKS, Free General Catalog, 100 pages. Text, vocational, educational, instructional subjects. Millions of volumes, new and used. Bargain prices. Books bought. Est. 1902. Long's College Book Co., Dept. PS, Columbus 1, Ohio.

JOHN Friend, Bookfinder, can get the books you want. Free Search Service. Box 2570PS, Long Beach 1, California.

EDUCATIONAL, Business Opportunity, Personal Improvement Books. Rainone Publisher, Middle Village 79, New York.

FREE Book Catalog—Many Interesting Subjects. Books Publishing Company, Amityville 39, New York.

READERS Digest 12 issues \$2. List free. Pearson's, 11129 Avenue N, Chicago.

ILLUSTRATED party fun booklets, 84 card tricks—25 lessons in hypnotism—60 easy magic tricks. Only 50c each. Illustrated catalog 10c. Aladdin Book Co., 210-PS 5th Ave., New York City.

WE want to buy old copies of Popular Science—any issue from period 1890 to 1915. Condition not too important provided books are complete with no pages removed. Write to Box No. 308, Tuckahoe, New York.

24 HYPNOTISM

FREE Catalog! Hypnotism, Autohypnosis! Books, Tapes, Records! Drawer PS697, Ruidoso, New Mexico.

FREE Illustrated Hypnotism. Selfhypnosis Catalogue. Write: Hypnotist, 8721 Sunset, Hollywood 46P, California.

HYPNOTIZE Successfully! Learn Easy, Fast, Modern Methods. Complete, Illustrated Course, including self-hypnosis and "Secret Nerve Pressure Technique" (Guaranteed Harmless)—\$1.00. H. Fowler, 850 Draper Ave., Schenectady 6, New York.

"HYPNOTIZE . . . One word . . . One fingersnap," on stage. Satisfaction—or refund. \$2. Hypnomaster, 846-S6 Sunnyside, Chicago 40.

"HYPNODISK" 50c. "25 Lessons Hypnotism" Book 50c. Box 1352-H, Philadelphia 5.

XRAY Mind! Hypnotize, one glance. Guaranteed \$3.00. Wamsteker, Box 10. Ottery, Cape, South Africa.

DIPLOMA, Degree correspondence courses, Hypnotherapy, Psychology, Science. Aured, Central Valley, New York.

25 MAGIC TRICKS, PUZZLES, ETC.

WORLD'S finest professional magic. Joker novelties. Giant illustrated catalog 10c. Top Hat, Evanston 13, Illinois.

3100 NOVELTIES, Jokes, Tricks, Gadgets. Funmakers, Hobbies. Big catalog 10c. Johnson-Smith, D-423, Detroit 7.

GAMBLERS winning, cheating, exposed. Book \$1.00. Catalog 10c. Book, Box 671, St. Louis 1, Missouri.

FASTEST Service to magicians for over 30 years. Send 10c for Douglas famous Catalog, 500 Tricks, containing magic for pocket, parlor, stage, with balls, coins, cards, cigarettes, ropes, silks, apparatus. Douglas Magicland, Dept. 20, Dallas, Texas.

FREE catalogue! Popular jokes, magic, novelties. Carling's, 758-D, Howard City, Michigan.

FREE! Illustrated magic catalog! Entertain great opportunities. Write today! Heaney, Famous Magician, Oshkosh, Wisc.

BE a magician! Large professional catalog of latest tricks, 35c. Ireland, F-109 North Dearborn, Chicago 2, Illinois.

TEN amazing novelties \$1.00. Catalog free. P. Lawson, Box 2072, Goodrich Sta., Akron 11, Ohio.

WHOLESALE! Thirty 10c Trick Novelties \$1.00! (Profits!) 1746-SW Market, Philadelphia 3.

ITCHING Powder, Trick Matches, Cigarette Loaders, 13 packages \$1.00. Arlaneco, Philadelphia 44.

"VENTRILLO" Voice Thrower 25c. Ventriloquist's Puppet 75c. Box 971-PS, Philadelphia 5.

26 COINS & CURRENCY

COINS from Formosa, Vatican, etc., plus foreign banknote, 10c with coin approvals. Littleton Coin Company, Littleton S2, New Hampshire.

GET Profit And Pleasure in collecting old coins. Send 10c for 56-page illustrated coin catalog. You'll be delighted with it. Send for it now. B. Max Mehl, Box 750-C, Costa Mesa, Calif. Largest rare coin establishment in U.S. Established 58 years.

32 PAGE Informative U.S. Illustrated coin list 10c. Stoney, 192-S Washington, Boston 8, Mass.

WANTED! Coins! Highest paid! Confidential catalog, \$1. Huber's National Building, Minneapolis, Minn.

WE buy Canadian coins. 20 page premium buying guide showing prices . . . 25c. Marles, Numismatist, Box 833, Calgary, Canada.

COIN Magazine, 160 pages. Sample 35c. Numismatic, 7320 Milwaukee, Chicago 31.

SELLOUT values! U.S. coins. Long list only 10c. Hugh's, 522-K Second Avenue N.W., Hickory, N. C.

INDIAN Cent plus Bargain Lists 10c. Hutchinson's, Box 4747, Philadelphia 34, Penna.

RARE 1880 to 1885 CC Mint Dollars \$2.50 ea. Roll of Ea. \$250.00 Uncirculated. Shultz, Salt Lake City 10, Utah.

LINCOLN cents: 1931-D- 1931- 1932-D- 1932-1933-D- 1933- 1934-D- 1939-D 1909-VDB- Condition fine only \$4.00. Berry, Box 306, Westminster, Calif.

SAN Francisco Mint Closed! Made only cents and dimes in 1955. In short supply and great demand. One each, brilliant uncirculated for 25c. Free coin lists with order. Bryson Coin Company, 612 White, Toledo 5, Ohio.

60 ASSORTED coins, \$1.00. 60 Assorted bills, \$1.00. Oddehon, Box 482, St. Louis, Mo.

SEVEN Brilliant Uncirculated Coins. Last two years complete mintage San Francisco with Price Lists \$3.00. Two sets—\$5.00. Louis Bell, Box 1575, Decatur, Alabama.

TWENTY Different Indian Cents \$2.50; Ten Different \$1.00; Three Different Flying Eagles \$5.75; List. Collector's Bargains, New Hope, Pennsylvania.

\$5. GOLD \$11.95. 1958 proof set \$2.50. 50 mixed Indian cents \$4.95. Whitman albums, any 5 \$1.75; 1959 retail guidebook \$1.75; premium handbook \$1.00. World's greatest bargain catalogue \$1.00 (Deductible on first \$10.00 order). Bebee's, 4514 North 30th, Omaha 11, Nebraska.

HALF dime 75c. 3c piece 50c. Price list 10c. R&M Coin Co., Box 5, Delanco, N.J.

COMPLETE United States coin bargain lists. Indianhead cent, 10c. Economy Sales, 156-B Dean, Mansfield, Massachusetts.

PROOF-Sets of Coins. 1958 set only \$2.65. 1957—\$3.00, 1956—\$4.00, 1955—\$6.00, 1954—\$7.00, 1953—\$12.00, 1952—\$18.00, 1951—\$29.00, 1950—\$47.00. Complete set 1950-1958 inclusive—\$120.00. Postpaid. Prompt shipment. Money-Back Guarantee. Free Price List. Dan's—Dan Morafka, A.N.A., 432-S 23rd Ave., San Francisco 21, California.

WOW! Silver Dollar. Brilliant. Uncirculated. 1884-O only \$1.50! Postpaid. And you get our new price list with it free! Free also, with your order a brilliant, uncirculated, Mexican coin! Thousands of coins in stock. Proof sets. Gold, silver dollars, cents, etc. We also buy coins. What do you have? And please name your price. Postal Products Company. Fast Mail Order. Joe Gordon, A.N.A., 5614-SC California Street, San Francisco 21, California.

28 STAMP COLLECTING

TWO \$5.00 United States stamps plus 20 different, 10c, with US approvals. Irwin Stamp Co., Box 1109, Brooklyn 30, New York.

AMAZING Offer! 200 U.S. stamps—including commemoratives, airmails, high denominations to \$1.00—only 10c to Approval Applicants!! Illustrated Bargain Lists free. Mystic Stamp Co., Dept. 55, Camden, New York.

ICELAND 10 different beautiful stamps for only 10 cents to applicants for our good old fashioned approvals. Old Colony Stamp Co., Dept. B, Milford, Conn.

UNITED States commemorative collection containing 33 different—10c. Approvals. White, 516-W Avenue L, Brooklyn 30, New York.

WEIRD Diamond Shape Coffee Stamps. Lovely Flower Triangle! First American big commemorative. Greenland Idol Dancer, etc. Free with approvals. Capital Stamp Co., Ferrysburg 10, Michigan.

225 STAMPS For only 10c! This mammoth value includes Airmails, Pictorials; stamps from strange countries cataloguing up to 25c each! Also Approvals, Mystic Stamp Company, Camden 55, N. Y.

WOW! 110 All Different Germany 10c Zeppelins, Semi-Postals, Airmails, High values, etc. Giant Catalog, bargain lists included with beautiful approvals. Jamestown Stamp, Dept. A78PS, Jamestown, N. Y.

FREE U.S. Stamps, 1943 Flag, Commemoratives Included in Collection of 25 Different, Plus Valuable \$5.00 Stamp. All for 10c Mailing Charge. Approvals. Willett Co., Box 338-T, Yorktown Heights, N. Y.

FREE—103 British Colony Stamps. Approvals. Enclose 10c for handling. Niagara Stamp, St. Catharines 672, Ontario.

100 DIFFERENT Stamps, 10c with approvals. Smith, 508U Brooks, College Station, Texas.

WORLDWIDE, 50 all different, absolutely free, just to introduce our incomparable approvals. Kent Stamp Company, GPO Box 87, Brooklyn, N. Y.

COLLECTORS wholesale mixture \$1.00. Jean Husak, 342 Liberty, Syracuse 4, New York.

64 PAGE U.S. Catalog Free. Stone, 192 Washington, Boston 8, Mass.

RED Cross Triangle, Christmas stamp, 25 others different, 3c. Approvals. Foth, Box 93, Passaic, New Jersey.

FREE gift set with approvals. Send 3c for postage. Crosby, 126 Cameron Ave., Colonial Hts., Virginia.

EXCEPTIONAL, 125 different, cataloging \$3.00, includes triangles, commemoratives, 10c, approvals. Reeves, Box 37597P, Miami 37, Florida.

FIRST U.N. Set. Among World's Prettiest, Only 10c. Approvals. Welles, Box 1246-V, NYC 8.

U.S. Stamps. Giant Bargain Catalog—10c. Raymax, 35-VX Maiden Lane, NYC 38.

FREE!! Flag Set plus Flowers Triangle. Approvals. Beaman, Dayton, Tennessee.

FREE—Mint British Colonies from North Borneo, Caymans, Seychelles, Dominica, Papua, New Guinea, Sarawak, Brunei. Free with approvals. Viking, Great Neck 5, New York.

DIAMOND Roosevelt, Pope Triangle, Greenland, Angola, 51 others 5c. Approvals. Longhorn, Box 3068P, Lubbock, Tex.

STAMP Finder, World Map and Encyclopedia of stamp issuing countries only 5c. Approvals. Goliath Company, Bethlehem K2, New Hampshire.

GIGANTIC Collection Free—Includes Triangles—Early United States—Animals—Commemoratives—British Colonies—High Value Pictorials, etc. Complete Collection plus Big Illustrated Magazine all free. Send 5c for postage. Gray Stamp Company, Dept. PR, Toronto, Canada.

COLOSSAL bargain over 100 different stamps including birds, flowers, sports, triangles. Everything 10c with approvals. Guy Paquet, Box 189A, Quebec 8, Canada.

ECONOMICAL 1/2-3c Approvals. 33,000 varieties. Dresel, Box 128-T, West Englewood, New Jersey.

90,000 STAMPS sale grabbag 30c. Big lot \$1. Extra special \$2. Giant assortment \$5. Persil, 436 N.Y. Ave., Brooklyn 25, N.Y.

500 FINE mixed U.S. 15¢. Wright, 201-P Mealey, Hagerstown, Maryland.

FREE United States Illustrated Catalog. H-S, 45 Bromfield, Boston 8, Massachusetts.

ALBUM only 10¢! Hundreds of spaces! Stampmart Company, Hartford 1, Connecticut.

100 OLD U.S. Stamps between 1861 and 1935 \$1.00. Rousch Stamps, 51 Chestnut, Mansfield, Ohio.

QUEEN Elizabeth Mint Sets! Barbados, Virgins, Gold Coast, Gibraltar, Dominica, Malta. 21 Bicolors—25¢! Beautiful Approvals. Gannon Stamps, Box 931, Canton 1, Ohio.

FREE—102 Worldwide Stamp Assortment. Approvals. Send dime for handling. Linstamp, St. Catharines 619, Ontario.

FREE mint set! Approvals enclosed. Mintco, 5151 Princeton, Memphis 17, Tennessee.

FREE! 15 Mint French Colonies; Interesting Approvals Accompany, Tropicana, Box 624-S, Oakland Park, Fla.

FREE U.S. list for advanced collectors. National, Box 60, Boston 1, Massachusetts.

ROCKET Mail Demand Free Details. Casa Filatelica Antillana, Ciudad Trujillo, Dominican Republic.

OLD scarce U.S. seconds on approval. Slightly defective, bargain prices. Hearnfeld, Clintonhill Station, Newark 8, N. J.

FREE! 25 Different Pictorials. Approvals. Marford, Box 48, Queens Village 29, New York.

100 DIFFERENT Austria 10c. Approvals. Irving Aronson, Box F, Newton Centre 59, Massachusetts.

14,000 DIFFERENT! Amazing new plan builds your collection systematically, country by country. Only 50¢ weekly. Free details. L. G. Ware, Stepney 70, Conn.

1000 DIFFERENT Worldwide Stamps \$1.00. Valued over \$20.00. Universal, Box 6, Kenosha 6, Wisconsin.

FREE Sample! Illustrated, informative, interesting. National Stamp News, Anderson, South Carolina.

CHINA, 25 different unused, 3c. Approvals. Gerstle, 1131 North Brand, Glendale 2, Calif.

FREE! 50 Different Portuguese; Colorful, Inexpensive Approvals. Elkhart, Box 33, Elkhart, Indiana.

RED Russia—28 all different unused, high catalog, 5c. Approvals. Hamilton, 1415 East San Antonio, El Paso, Texas.

U.S. Mint Flag Set, \$1.00. Free Price List. Brooks, 2323P Avenue X, Brooklyn 35, N. Y.

800 MIXED U.S. big variety 25c. Monjar, Fairmount, Cincinnati 14, Ohio.

FREE U.S. commemorative list. James Sales Co., 8230 Pulaski Highway, Baltimore 6, Maryland.

ONE Pound General Foreign Stamp \$2.50. Veteran Frank Stroskey, 223 Market Street, Perth Amboy, New Jersey.

300 DIFFERENT Given Free with Approvals. Particulars. Windsor Stamps, 8834 Cornell Ave., Chicago 17.

60 DIFFERENT U. S., including 30 Commemoratives 25c. No approvals. Seidenberg, Appleton, Wisconsin.

25 DIFFERENT Commemoratives 1893 up 10c. U.S. Approvals. K & B, Box 70, Brooklyn 23, New York.

SELECT U.S. on approval. Mint, used. Kingsbury Stamps, Fairfax, Vermont.

U.S. Commemorative First Day Cover Free With Approvals. Arrow Stamps, Box 4905, Oklahoma City 9, Oklahoma.

PENNY Approvals jammed with Bargains. For better values, try Putnam Stamp Company, Mahopac, New York.

U.S. approvals. Low prices. Eagle Stamps, Romine Ave., Pittsburgh 26, Penna.

NOW try us. Just look at our U.S. & Foreign approvals. Sure to please. Laclede Stamps, 4973A Columbia Ave., St. Louis 9, Mo.

1000 DIFFERENT worldwide with approvals only. A. Jacobsen, Crompond, N.Y.

ADVENTURE — Fun — Profit — with our approvals from the farthest corners of the world. Send dime for strange samples. Cosmo Stamp, Box 158, Forest Hills 75, New York.

"MONACO Nudes" complete 25c. Approvals. Royal Stamp Company, Tamaqua

29 ANTIQUES, RELICS & INDIAN GOODS

SELLING 100,000 ancient Arrowheads, Spearheads, Tomahawks, etc. List free. Lear's, Glenwood, Arkansas.

SCALPING Knife. 3 War Arrowheads \$2.00. Catalog Free. Arrowhead, Glenwood, Arkansas.

30 MINERALS & PRECIOUS STONES

ROCKHOUNDS: Visit the collectors paradise. Circular Free. — Rockhound, Wenona, Illinois.

LARGEST gem and mineral magazine tells how to have profitable fun with rocks, gems, jewelry. Monthly. \$3.00 year. Sample 25c. Gems & Minerals, Dept. S-7, Mentone, California.

GEMCUTTING — Silvercraft magazine. Learn to cut gems, make jewelry. Ads give sources equipment, gems for cutters, collectors. Free literature. Sample copy 25c. Lapidary Journal, Del Mar 3, California.

EARTH Science — Rockhounds National Magazine. Subscription \$2.00. Sample 35c. Box 1357-PS, Chicago (90), Ill.

SAPPHIRE, Topaz, tourmaline, garnet, peridot. Five uncut gems, \$1.00. Bargain list. Gems, jewelry mountings, 25c. Gem cutting equipment, 25c. O'Brien's, 1116N Wilcox, Hollywood 38, Calif.

31 HOBBIES, COLLECTIONS

INVENTING can be an interesting and profitable hobby. Write for complete particulars. Institute of American Inventors, Dept. 30-E, 635-F St., N.W., Washington 4, D. C.

COLLECT old handcuffs, prisoners' shackles. Unusual, exciting hobby. 25¢ brings list illustrated article. Patterson Smith, 269-A Shepard Avenue, E. Orange, N.J.

FREE purple heart when ordering 40 new U.S. Military shoulder patches, ribbons. Postpaid \$1.00. N. Kimmel, 10436 Cheviot Dr., Los Angeles 64, California.

32 PHOTO FINISHING, PHOTOCOPIES, ETC.

PARTICULAR? 8 Jumbos 40c; 12—50c. Special; 35mm, 36 exposures \$1.25 Intro. Offer. Flash Foto, Box 36H, Brooklyn 4, N. Y.

KODACOLOR Film Processed, 90c. Prints, 32c each. 25% discount with this advertisement. Mayfair Photos, Box 617-S, Toledo 1, Ohio.

TWELVE Exposure rolls 39c. Wallets 20 for \$1.00. Lincoln Studios, Dept. L, Box 13, Lincoln, Nebr.

40c FILM Developed 8-12 Jumbos or 2 prints each exposure and roll your size film \$1.00. Mellers. BIG PIC, Jefferson City, Missouri.

FILM service specialists for 37 years. 8-exposure film developed and 8 jumbo prints, 35c; 12-exposure, 55c; additional jumbo prints, 5c each. Dated in packets. Kodachrome processing, 69c; prints 25c. 35mm Kodachrome, Ektachrome, Ansochrome 20 exposures mounted, \$1.35. Save 25% on all sizes, types fresh Kodak film movie or still. Globe Photo, Box 3508-A, St. Paul, Minnesota.

FAST Film Service: Black and White: Eight Exposure 40c. 12 Exposure 60c. 20 Exposure \$1.00. Reprints 5c. Kodachrome. Process 90c. Prints 32c each. Ansochrome, Ektachrome \$1.40. Kodachrome \$1.50 Mounted. Finest quality over 40 years. Mailers. Mail Order Photo Service, Box 297, Watertown, Wisconsin.

8-HOUR service on deluxe jumbo prints. 8-Exposure roll developed and 8 jumbo prints 40c. 12 exposure 55c, 16 exposure 70c; 35 mm. 20 exposure 75c, 36 exposure \$1.25. Jumbo Deckledge Reprints 4c each. Contact prints made if specified. Bay Photo Service, P. O. Box 210, Oakland, California.

KODACHROME processing 20 exposure, 8mm. Roll movie \$1.00. Ansochrome, ektachrome \$1.00. Free mailers. Nu-color Laboratories, Box 191, Hartford 1, Connecticut.

KODACOLOR July special 8 exposure roll \$2.75. 12—\$3.75. Black and white 8 exposure roll 35c, 12—50c. Western Photo, PS78, Box 298, San Francisco 1.

PROFESSIONAL portraits from your negatives. Three 5 x 7's attractively mounted. \$1.00. Imperial Photo, 827 Wakeforest, Mt. View, Calif.

33 MOTION PICTURES, SLIDES SOUND EQUIPMENT

MOVIE Camera Film 8 mm roll \$1.50. 16mm 100' \$3.00. Free processing. Better Films, 742 New Lots, Brooklyn, N. Y.

SAVE 50%! Guaranteed-fresh color, b&w movie film! 8mm, 16mm. Free catalog! Eso-H, 47th Holly, Kansas City 12, Mo.

FREE catalog. Save \$\$\$ Fresh 8mm, 16mm B&W and color film. Home processing equipment. Superior Bulk Film

TAPE recorders, hi-fi components, tapes. Unusual values. Free Catalog. Dressner, 69-02 174 Street, Flushing 65, New York.

RECORDERS, Hi-Fi. Free Wholesale Catalogue. Carston, 215-PS East 88, New York City 28.

FREE Catalogues. 5,000 8-16MM Films. International Films, Greenvale, New York.

8MM-16MM Movies, 50 ft. 79c—Special introductory offer. Comedies, cartoons, travel, animals. Send 79c now. Free catalogue with order. Movieland Films, Inc., Box 10S, Van Nuys, Calif.

16MM Sound Films. Sold, Exchanged. Duquette, 97-P Snow, Fitchburg, Mass.

34 CAMERAS, PHOTO SUPPLIES

PHOTOGRAPHY For Pleasure or profit. Learn at home. Practical basic training. Long established school. Free booklet. American School of Photography, 835 Diversey Parkway, Dept. 172B, Chicago 14.

FREE! Free! 72 page photographic catalog. Write to "Photographic Headquarters Since 1899." Dept. 437, Central Camera Company, 230 S. Wabash Avenue, Chicago 4, Illinois.

RETIRE! Use car battery, camera for electrolytic etching nameplates, signs. Acme, Box 9647, Northside Station, Jackson, Mississippi.

35 MUSICAL INSTRUMENTS, SONG WRITERS & RECORDS

WANTED! Poems for musical settings. Write Songwriters' Service, Clifton, N. J.

SONGPOEMS and lyrics wanted. Mail to: TinPan Alley, Inc., 1650 Broadway, New York 19, N. Y.

SONG poems wanted. Free examination. Send Poems. McNeil, Master of Music, 1112-PS Wilshire, Santa Monica, California.

ACCORDIONS Wholesale—10 day trial. Free Catalog. American Accordion Center, 5329-PS-7 Belmont, Chicago.

POEMS Wanted for New Songs and Recording. Immediate Consideration. Send Poems. Songcrafters, Box 6145, Acklen Station, Nashville, Tenn.

SONGWRITERS: Recording Company Wants new songs. Royalty basis. National sales, promotion if selected. No charge for melodies. Send material. Music Makers, Dept. G-37, Box 2507, Hollywood, California.

SONGS Into \$\$\$\$\$\$—Share \$33 million dollars yearly for New Songwriters, Song-poets. Any subject, songs composed, published, promoted by largest firm. Information, appraisal Free. Send Nordyke Music Publishers, 6000 Sunset, Hollywood 28PS, California.

POEMS wanted for new songs. Send poems. Free examination. Crown Music Company, 49-P West 32 Street, New York City 1.

ACCORDIONS! Lowest Wholesale Prices Guaranteed. Save up to 75%. Free Home Trial. Trades Accepted. Free Color Catalog. Accordion Manufacturers, Dept. 78-P, 2003 W. Chicago, Chicago 22.

POEMS Wanted for musical setting and recording. Five Star Music Masters, 646 Beacon Building, Boston.

POEMS—Songs needed by recording artist. Zeal, P. O. Box 152-S, Jackson Heights 72, New York.

COMPLETE Music Service For Song Writers. Jerry Colonna, Box 888P, Burbank, Calif.

PHONOGRAPH Records cheap, postpaid. Catalogue. Paramount, Box 242-S, Williamsport, Penna.

ELECTRIC Guitars, amplifiers, wholesale. Free catalog. Carvin, PSM, Covina, California.

SONGWRITERS! Protect your ideas! Hold all poems, songs! Write for safe, correct procedure! Song Service, Dept. PS, 333 W. 56th, New York 19.

36 RADIO, TELEVISION SUPPLIES & EQUIPMENT

FREE! Giant Bargain Catalog. Transistor, "Sun" Radios, Kits, Portables, Audio, Electronics, Photographic, Optics, Tools, Household. Write Lektron, 131S Everett Ave., Chelsea, Massachusetts.

ENJOY TV in your pocket. Ekeradio, 650 North Fair Oaks, Pasadena, California.

RADIO Course only \$22.95. Includes all tubes, parts, tools, instructions. Write for full information. Progressive "Edu-Kits" Inc., Dept. 556A, 1186 Broadway, Hewlett, N.Y.

TRANSISTOR radio complete kit \$7.95. Walter, 3969 E. 29, Cleveland 5, Ohio.

TV picture tubes, brand new. Wholesale prices. Bulletin free. Imperial, Dept. P, 2324 N. 3rd, Milwaukee 12, Wisc.

GOVERNMENT Surplus—Radios, Mine-Detectors, Radar, Snooperscopes, Parabolic Reflectors. Amazing Picture Catalog

KITS: shortwave radio \$3.50; crystal radio 75c. Alliance, 2059 60th, Brooklyn 4, N. Y.

ELECTRIC Guitars, amplifiers, wholesale. Free catalog. Carvin, PSR, Covina, California.

37 BUSINESS OPPORTUNITIES

OPERATE profitable mail order business. Write Walter Service, 4159-B East 112th, Cleveland 5, Ohio.

FIX Typewriters. Inexpensive home course teaches Factory Secrets. Free Booklet. Write, Typewriter, Tarentum 2, Pennsylvania.

WHOLESALE—Get the big merchandise—furniture appliances, TV's, clothing, tools, auto accessories—most anything. Save half. Literature Free. Associated Wholesalers Service, 1016-C Starr, Burlington, Iowa.

\$70 WEEKLY—Home, spare time. Simplified mail bookkeeping. Immediate income—easy! Auditax, 34757D, Los Angeles 34.

11,000 NEW Prospects Daily. Baby record books, shoes, albums. Sell mailorder. Use our literature. Write: No-Co-Ro, Capitola, California.

YOUR envelopes addressed accurately, reasonably. Fast service. We have capable addressers in your city. Glenway System, Box 6568, Cleveland 1, Ohio.

BRUSH Plating Outfits for plating articles in the home and shop. No tanks necessary. Silvering Mirrors spare or full time. Free particulars. Gunmetal Co., Ave. E, Decatur, Illinois.

BE appointed state notary public now. Write—Stationers, Boerne, Texas.

HOME-Import Mail Order Business—Import profitable items below wholesale. Experience and product investment unnecessary. Full spare time. Famous world trader guides you. Free list "157 imports," details. Mellinger, P-697, Los Angeles 24.

"50 NEW Home-Business Ideas" Booklet, sample Free. Spray exotic Velvet-Suede on anything. Flockcraft JY, Los Angeles 61.

GROW Orchids at home. Profitable, fascinating. Successful home grower explains special light, temperature and humidity conditions orchids need. Free—Full details. Orchids, 100 S. Vermont, Los Angeles 4.

WANTED—Limited number intelligent Men and Women to work at home on exclusive Mail Order Business proposition. No selling—we furnish everything including literature, names, addresses, stock and ship items for you. Free Details. Mail Order Distributors, JY (Franchise Division), Los Angeles 61.

PLASTERCRAFT molds, liquid rubber, plasters, flocks, candle supplies. Catalog and manual free. Jayhawk Plasters, Blue Rapids, Kansas.

LEARN Mailorder Selling. Pays Big! Free Colliers' Reprint! Elliott, 216-B W. Jackson, Chicago 6.

MAKE Money Writing Short Paragraphs. Information Free. Barrett, Dept. CX-28, 7464 N. Clark, Chicago 26.

IMPORT Mail Order Business. New Directory lists over 400 manufacturers, exporters of the world. Complete import procedures, international drop ship methods. Capital unnecessary. Free details. Associated, Box 52-P8, Burlington, Iowa.

FREE picture folder, "How to Make \$3,000 Yearly Sparetime. Backyard, Raising Earthworms!" Oakhaven-42, Cedar Hill, Texas.

GROW a living Miniature Forest or orchard (only inches high), that bears tasty fruit at home. Learn amazing Dwarfing secrets! Fascinating hobby. Profitable Home-Business Opportunity. Free Seeds and Plan. (State your age). Miniature Nurseries, Dept. JY, Gardena, California.

INVISIBLE Reweaving: \$5 in one hour possible reweaving burns, tears, moth-holes. Spare-Full time. Free Details. Skill-Weave, Dept. C-137, 335 W. Madison, Chicago 6.

GROW Expensive herbs for us! Big profits home-business of your own. Year around profitability! We supply everything necessary! Send for free rare seeds and revealing plan. (State your age.) National Herb Exchange, Dept. JY, Gardena, California.

CAMERA owners! Earn \$50 weekends! Instructions \$1.00. Information free! Kline, 935-PS North Austin, Chicago 51, Illinois.

MAKE Extra money. Cash commissions. Everybody buys easy-to-sell Advertising Book Matches. Union label. Big variety—Glamour Girls, Scenics, Hillbillies. Powerhouse selling kit Free. Steady repeat business. No experience necessary. Superior Match Company, Dept. PX-758, 7528 S. Greenwood, Chicago 19.

QUICK profits, with no capital! Take orders for magazines your neighbors like, want. Make cash on the spot! We show how with Free kit. Get yours now. Write McGregor Magazine Agency, Dept. 340, Mount Morris, Ill.

\$100.00 WEEKLY spare room. Raise red-worms soilless way. Odorless, Charlie Morgan, Box 116C, Bushnell, Florida.

MINK Raising information free. Complete. Lake Superior Mink Farm, Superior E E5, Wisconsin.

YOUR Own High Profit Business. Sell Name Brands, full or part time. No inventory—no investment. More than 2000 Name Brand items; lowest wholesale prices. Watches, jewelry, cameras, hi-fi radio-phonos, appliances, housewares, hardware, power tools, luggage, musical instruments, garden equipment, sporting goods, toys, many others. 8 Floors of Name Brands. Million dollar inventory. Send for Free beautifully illustrated catalog Now! Separate dealer price list. H. B. Davis Corp., Dept. 14, 145 West 15 St., New York 11, N.Y.

MAKE \$3 to \$5 hour sharpening saws, lawnmowers sparetime at home. Free book. Charles B. Foley Co., Columbia Heights, Minnesota.

\$250.00 WEEK profit possible. Earn at home spare time with fascinating Printing method. \$5 starts you—send no money now. Free Confidential Facts and Valuable Samples. Screen-Print JY, Los Angeles 61.

NEW Importers Guide Ready to Operate Mail Order Drop Shipments Worlds Wide \$2.00. Lindsay May Co., Box 381, Delhi, Calif.

FREE "Franchise Profit Letter" describes nationwide opportunities. Exclusive distributorships, dealerships, agency operations. Write today. National Franchise Reports, 333 North Michigan, Chicago 1.

"MAILORDER Laws and Regulations" and "Mailorder Rules for Beginners." Learn about necessary licenses, different taxes, legal requirements, etc. Both books, \$2.00. Tasker, Box 3131, Alexandria, Va.

MAIL Order! Succeed with your own proven mail order business. No inventory. We dropship and show you how easy big profits can be made. Write Gifttime, 919 Walnut, Dept. 105, Philadelphia 7, Pennsylvania.

YOUR own sound, exclusive mail order business engineered by dean of creative specialists. The proved, tested way to success. Moderate capital. Free program, opportunity bulletin, evidence. Errol Slater, 305 West Eighth, Los Angeles 14, California.

NATURAL Molding Rubber; Extra Thick. Free Sample. W. Wooley, 1016-B Donald, Peoria, Illinois.

FREE Literature—Make Big Money Raising Fishworms and Crickets. Carter Farm, Plains, Ga.

OPPORTUNITY to earn \$15,000-\$30,000 annually. Franchise protected. Granted on \$12,500 basis. Live at home. No merchandise to buy. Selfemployed. One of most exclusive and noncompetitive Businesses in United States and Canada. Send for free explanatory booklet. Harrell and Company, Box 8-D, Louisville, Illinois.

\$34.70 TWO Hours. Manufacturing. No Selling. Carlayn Castings, 1803 Fremont, Rapid City, So. Dakota.

BUY Direct From Factories—Appliances, Cameras, Watches! Free details! Cam Company, 6810PS-20th Ave., Brooklyn 4, New York.

INCOME from local information. No Selling. Write Neherco, LaVerne, Calif.

CASH from Sawdust, Tin-cans, Newspapers. Over 200 methods. Instructions \$1.00. Charles Company, 12-XBK, Norwood, Ohio.

MARKETS Everywhere. Make Artistic concrete birdbaths, pottery. Chemical coloring. Home workshop. Hundred varieties. Hollywood Cementcraft, 8527-F Wonderland, Hollywood 46, California.

MAKE New Greaseless Doughnuts In Kitchen. Sell stores. Free recipes. S. Ray, 3605 South 15th, Minneapolis 7, Minnesota.

INTERNATIONAL home mailorder business! Experience unnecessary. Earnings unlimited. Write: Foreign Traders, Mera-mec Bldg., St. Louis 5-SA, Mo.

MAIL Order—advertising agency executive reveals sensational no-risk advertising and merchandise methods. Start in office or home—minimum capital—positive profits. Free details; Impact! 3407 Prospect Ave., Dept. 2-7, Cleveland 15, Ohio.

MAKE extra money in spare time. Age or education unimportant. No selling, no investment, respectable. I made \$10,000 so can you. Free details, William Trippet, Box 4032-S, Pasadena, Calif.

FREE sharpening plan. Earn money. Precision sharpening cutters, saws, scissors. Treyco Products, N. Tonawanda 1, N. Y.

METALIZE Baby Shoes; Repair Dolls; Rebuild Batteries; Catalogue "75 ideas" Free. Universal, Box 1076-B, Peoria, Illinois.

TREMENDOUS possibilities in mail order. I retired after five years. Write N. Cole, 217 West 49th, Bradenton, Florida.

CANDIED Popcorn and Potato Chip Equipment. Eakins, Box 933-B8, Springfield, Ohio.

MUSHROOMS Quicker, Easier, Cheaper. Newest Facts Free. Spawn \$1.00. Luxorco, 641 South 19th, Newark 3, N.J.

MAKE flexible molds. Cast plaques, figurines. Free sample. Tooker, 1045-A Fairview, Hamilton, Ohio.

OPERATE mailorder business selling schools instructional materials. Practical Aids, Estacada, Oregon.

WE Pay \$3.50 lb. dried. Grow Mushroom. Cellar, shed and outdoors. Spare, full time, year round. We have 25,000 customers. Free Book. Washington Mushroom Ind., Dept. 178, 2954 Admiral Way, Seattle, Wash.

LIQUID Rubber. Make flexible molds. Free Sample. Chaney, 1907-C East Rd., Jacksonville 11, Fla.

PIANO Tuning learned quickly at home. Tremendous field! Musical knowledge unnecessary. Information free. Empire School of Piano Tuning, Champaign, Illinois. (Founded 1935.)

MAKE \$200.00 Monthly Spare Time with Jigsaw. Free Details. Elkman, 346 N. Summit, Sioux Falls, S. Dak.

WANT money? Here is a simple but lucrative homework proposition. Send \$2.00 for fascinating Mail-Order Plan anyone can operate. Leroy Parker, P.O. Box 8425, Jacksonville 11, Florida.

INTERNATIONAL Mailorder Business. Complete setup—not just instructions. Hermes, 152-R West 42, New York City 36.

\$250 WEEK reported! Free book "505 Odd, Successful Businesses." Work home! Expect something Odd! Pacific-36C, Oceanside, California.

FREE Folio "\$5,000-\$45,000; Unlimited Vacations." No merchandise. Unknown! Work home! Haylings—S-16, Carlsbad, Calif.

\$6,000 FOR Mister, Mrs.: \$3,500! Free "Secret Journal" Plan. Magical! Work home! Publico-N33, Oceanside, Calif.

MAKE Big Profits clipping newspaper items for publishers. Instructions explain how. Particulars free. National, 81-N, Knickerbocker Station, New York.

BEAUTIFUL mutation mink—one male, two females with pens. \$110.00. Guaranteed. Month's feed free!! Blue Sky Mink Ranch, Henry, Ill.

UNBELIEVABLE profits making concrete drain tile. Details Free! Ceeten Products, Cornelia, Ga.

\$7500. YEARLY; invest only 20 hours weekly. Respectable, permanent. Not selling. Instructions \$1.00; details 3c. Young, 1320 Lynnwood, Johnson City, Tenn.

COLORGLAZED Concrete pottery made without molds. Patented method. Cemetery products, novelties, tiles. Basement leak-sealing. Money-making projects. Booklet, details free. Men only. National Potteries, Grand Rapids, "Minnesota."

OUR Postman last year left \$4,852 monthly average in our postbox. Complete mail order method showing how we did it and how you may do it, too. \$5. Operate anywhere. Research, 1848 Stewart, Springfield 7, Missouri.

VENDING Machines—No Selling. Operate A Route of Coin Machines And Earn Amazing Profits. 32-Page Catalog Free. Parkway Machine Corporation, Dept. 18, 715 Ensor Street, Baltimore 2, Maryland.

LADIES nylons \$4.95 dozen. Allsheer Mills, 21831 Cloverlawn, Oak Park 37, Michigan.

UNLIMITED: \$20,000 - \$40,000 — Retire home. Free "Profit Letter". Capt. Wm. Lewis, Tampa 9, Florida.

MAKE \$46 From Square Foot Plywood; Jigsaw necessary. Free Details. Woodarts, Bridgewater, Mass.

QUICK-brick. Home improvement bonanza. Speedy production, our methods. High profits. Work from Home. Free book. Art-Stone, Box 856-C, St. Louis, Mo.

38 MONEYMAKING OPPORTUNITIES

HOTTEST Mail Order Plan Ever! Sell photos, films, art novelties. Huge proven profits! Free Details! Profits Unlimited. Dept. 2K, 15015 Ventura Blvd., Sherman Oaks, Calif.

SELL Titania Gems: far more brilliant than diamonds. Catalog 10c. Diamonite, 2420-S 77th, Oakland 5, California.

SPARETIME Repeat Profits Taking Magazine Subscriptions, Special Offers. Cassell Agency, Boynton Beach 7, Florida.

DETECTIVES—Work home—Travel. Experience unnecessary. Detective Particulars free. Write Wagoner, P-125 West 86th, New York 24.

SELL Yourself, Sell Neighbors Aluminum Awnings Wholesale. Save 50%. Groff Awnings, Fairland, Indiana.

BIG Money Raising Giant Tropical Worms. Spare room, basement, garage. Amazing odorless, soilless method. Charlie Morgan, 116B, Bushnell, Florida.

HUGE Profits! Opportunity manufacturing concrete utility item. Send \$2.00 for plans, instructions. Cretepost, Box 38, Windsor, New York.

MAKE Big Profits in your spare time selling nation's hottest "Do-it-yourself" item. Our new, inexpensive Underground Lawn Sprinkler kit makes every homeowner a potential customer! Send \$1.00 for full particulars, illustrated brochure, price information, operation data. Everything to set you up in business! Proven money maker. Exclusive franchises. Empire Co., 53 Spencer, Scarsdale, New York.

EASY to start rubber stamp business at home in spare time. Make up to \$9.80 an hour without experience. Facts free. Write to Roberts, 1512 Jarvis, Room CR-3-H, Chicago 26.

AMAZING successes through franchises! Become exclusive franchise holder your territory. Information rushed. National Franchise Reports, 333 North Michigan, Chicago 1.

DOLLARS Every Day! Amazing Magic Mailorder Plan. Setup Free. Miller, Box 588-A, Oshkosh, Wisconsin.

MEN — Women! Start Money-Making Plastic Laminating Business at home in spare time. Material that costs 11c brings back \$2.58. No canvassing or selling but mail orders bring in \$20 a day. Write for full particulars Free. Rush name on postcard to Warner, Room CL-3-H, 1512 Jarvis, Chicago 26, Ill.

FREE Literature—Make Big Money Raising Fishworms and Crickets. Carter Farm-11, Plains, Ga.

DRAW pictures on typewriter, profit, fun. Free sample pictures, literature. Typeart, Box 257, Mountain Grove, Missouri.

TYPEWRITER; camera-owners. Earn handsome profits. Harwood, 533 South Presa, San Antonio 3, Texas.

\$35.00 WEEKLY addressing envelopes. Instructions \$1.00 Refundable. Adservice, Spring Valley, New York.

MAKE Money, operating Mail Order Business card brokerage. Vosacek Printing, 4444PS Ute, San Diego 17, Calif.

WE Pay \$3.50 lb. dried. Grow Mushrooms. Cellar, shed and outdoors. Spare, full time, year round. We have 25,000 customers. Free Book. Washington Mushroom Ind., Dept. 179, 2954 Admiral Way, Seattle, Wash.

MANY earn \$50.00-\$100.00 weekly spare-time. Guaranteed instructions \$1. (Refundable). Modern, Box 206, Sarasota, Florida.

DOES your motor pump oil? New discovery. Bulletin free. Big profits. Imperial, Dept. M, 2324 N. 3rd St., Milwaukee 12, Wisc.

MUSHROOMS Quicker, Easier, Cheaper. Newest Facts Free. Spawn \$1.00. Luxorco, 641 South 19th, Newark 3, N.J.

FREE folio "Money without working." Investico, 328-T Eleventh, West Bend, Wisconsin.

MAKE Money Clipping Newspaper Articles For Publishers! Detailed plan. News-craft, PS-983-E Main, Columbus 5, Ohio.

\$30-\$60 WEEKLY addressing envelopes for advertisers. Instructions \$1. Refundable. Reiss, 210 Fifth Ave., Suite 1102-S, New York 10.

MAILORDER business, professional, pandemic, profitable. Dynamic, Box 295-S, Rutherford, New Jersey.

READY made circulars with products. Write. Schultheis, Box 449, Irwin, Penna.

MAKE Big Profits clipping newspaper items for publishers. Instructions explain how. Particulars free. National, 81-N, Knickerbocker Station, New York.

FREE Folio. "\$5,000-\$45,000; Unlimited Vacations." No merchandise. Unknown! Work home! Haylings—S16, Carlsbad, Calif.

GET \$25 orders in your mail keep every cent. Write for full free details. Gray Co., Box 948-P, Vallejo, Calif.

START Big-Pay business at home in spare time. No experience needed to operate little table-top machine for bronzing baby shoes. Make \$5.46 profit on every pair. Full particulars free. Send postcard to Mason, 1512 Jarvis, Room CM-3-H, Chicago 26, Illinois.

VENDING Machines—No Selling. Operate A Route of Coin Machines And Earn Amazing Profits. 32-Page Catalog Free. Parkway Machine Corporation, Dept. 19, 715 Ensor Street, Baltimore 2, Maryland.

MONEY-making opportunities unlimited! Earn good money selling fabulous money-making toys collector's items, gifts, jewelry, household items, gift wraps, and greeting cards. Reasonably priced. All sell on sight. No big investment. No experience needed. Big illustrated catalog contains over 700 money-makers. Write for free catalog. Samples on approval. North Star, 8-578 Finch Bldg., St. Paul 1, Minnesota.

PROFITABLE books, plans.—Details 25c (Refundable). Chapman, 33 Elizabeth, Hammond, Indiana.

\$15,000. PROFIT in one year possible, investing \$5.00 weekly. Respectable field. Method of purchase guarantees 15% profit. No advertising, inventory, selling or experience necessary. Complete detailed Plan, only \$1.00—Satisfaction Guaranteed. Columbia Enterprises, 8203-PS, Grubb Road, Silver Spring, Maryland.

MAIL newspaper clippings daily for cash. Ketchum's Advertising, 1058-B, Springfield, Illinois.

MAKE Money Writing Short Paragraphs! No tedious study. I tell you what to write, where and how to sell; and supply list of editors buying from beginners. Many small checks add up quickly. Write to sell right away. Send for free facts. Benson Barrett, Dept. C86-U, 7464 Clark, Chicago 26.

38A BUY IT WHOLESALE

LARGEST Wholesale Supply Source in U.S. Get 23 free catalogs. Furniture, clothing, appliances, autos and accessories, farm equipment, tools, housewares, hobby supplies. Free details. Associated Wholesalers, Box 52-C, Burlington, Iowa.

BUY Wholesale! 25,000 Nationally Advertised Products. Get Amazing Dealer Catalogs. Complete Details Free. American Wholesalers, 1841-G Levee, Dallas 7, Texas.

BUY Vitamins Wholesale! Free Catalog! Vita-Best, 487-SV-Broadway, New York.

BUY wholesale! Tremendous discounts! Write United Wholesalers, 1265-P Broadway, New York 1, N. Y.

ELECTRIC Guitars, amplifiers, wholesale. Free catalog. Carvin, PSW, Covina, California

WHOLESALE automobile catalog—discounts to 25% or savings to \$1200.00 or more. Also big multicolor wholesale catalog—housewares, appliances, binoculars, luggage, radios, phonographs, recorders, projectors, typewriters, sewing machines, furniture, watches, jewelry. Name brands. Huge discounts. Postcard: Selbyco, Decatur 170, Ill.

39 FORMULAS, PLANS, ETC.

FORMULAS—All kinds. Latest products. Literature free. Kemico, Park Ridge 15, Ill.

MODERN Specialty Formulas. Profit engineered products. Free literature. Alpha-Midwest, LaPorte, Indiana.

LATE Modern Manufacturing Formulas List Free. Chemical Service, Martville, New York.

SPECIAL Formulas for latest money-making discoveries. New! Good! Profitable! Valuable Literature Free! Miller, Chemist, 1517-N, Tampa, Florida.

40 PLASTICS

NEW Liquid Casting Plastic, clear, colors. Embed real flowers, coins, photos. New Manual shows fine things you can make at home and sell at big profit. Send 25c. Castolite, Dept. H-102, Woodstock, Illinois.

LAMINATING Supplies. Price List Free. Solomson, 46 Cornhill, Boston 8, Mass.

LEARN Plastics Fabrication For spare time income. Low cost home training now available. Write for free booklet. Interstate Training Service, Dept. D-2, Portland 13, Oregon.

PLEXIGLAS — Any thickness — Clear — Colors — Cut to size — Clear Rods — Tubing. McClarin Plastics, P.O. Box 168B, Hanover, Pennsylvania.

PLASTICS! Casting, molding, modeling and accessories. Illustrated catalog 25c. Castacraft Corp., Dept. C-62, P. O. Box 555, Palo Alto, California.

PLASTIC laminating, cards, plaques, etc. Laminating machines. Burr, 330 East Center St., Kalamazoo, Mich.

PLEXIGLAS. Square foot cost, 1/16"—\$1.20; 1/8"—\$1.52; 3/16"—\$1.86; 1/4"—\$2.21; 3/8"—\$3.23; 1/2"—\$4.36. Colors add 10%. Send 15% for postage. Aristocrat Plastics, 23 Sussex Avenue, Newark, N. J.

SELF-sealing laminating transparent plastic, 12 sheets 3"x4" \$1.00. Williams, 187 1/2 Merrimon, Asheville, N. C.

41 CHEMISTRY AND PHYSICS

FREE Scholarship, Major Course in Chemistry! Diploma. Also, valuable chemical library and chemicals. Catalog free. National School of Chemistry, Redwood City, Calif.

CATALOG with 3000 illustrations of laboratory and physics apparatus sent for \$2.00 Postpaid. Laboratory Materials Company, 1328 E. Hyde Park Blvd., Chicago 15, Ill.

ILLUSTRATED Catalog; Chemistry, mineralogy, biology 25c. Tracey Laboratories, Evanston, Illinois.

SCIENCE for Americans — Amateur science club. Chemical-equipment list; experiments; literature; awards. \$2.00 year dues, 25c list. 2525 Honolulu, Montrose, Calif.

CHEMICALS and apparatus for industrial, analytical and private laboratories. Catalog 25c. Dept. M-26, Biological Supply Co., 1176 Mt. Hope Ave., Rochester 20, N.Y.

EXPERIMENTERS:—"Bargains Galore Catalog."—25c (Refundable). Hagenow Laboratories, Manitowoc, Wisconsin.

CHEMISTRY set: chemicals, experiments, 50c. Kits, 1452 Drake, San Pablo, California.

AMAZING new book of science experiments, formulas, and catalogue of laboratory supplies. Only 25c. National Scientific Co., Dept. PS-7, 500 West Road, Lombard, Illinois.

CHEMISTRY, Physics, self-education books. Information free. Franks, 3121 Racine, Chicago 8.

CHEMICALS, glassware catalog, 25c. Laboratory Sales, Box 161-B, Brighton, Mass.

42 HELP WANTED REPORTS

AMERICAN Overseas Jobs. High Pay, Men, Women. Transportation Paid. Free Information. Transworld, Dept. 4C, 200 West 34th St., New York 1.

FOREIGN Jobs—Latin America, Alaska, Canada, up to \$1500 monthly. Up-to-date 1958 Foreign Service Directory gives complete information; hot list of firms hiring for Military and Civilian Construction, Aircraft, Oil, Exporters-Importers, Mining. How-When-Where to apply. 11th Successful year. \$1.00. Global Reports, Box 8873-P, Los Angeles 8, California.

HIGH Paying Jobs, Opportunities, foreign, USA. All trades. Companies pay fare. For information write Dept. 57L, National Employment Information, 1020 Broad, Newark, New Jersey.

COPYRIGHTED Reports. Best paying jobs with travel, adventure, promotions. Construction, aviation, shipping, oil fields, laborers, clerical, trades, supervisory, factory, unusual opportunities. Skilled—unskilled. Foreign—stateside. Men—Women. Only \$2.00 (\$2.25 Airmail). (C.O.D.'s Accepted), including registration-advisory service. Satisfaction guaranteed. Included free: Special reports on Alaska-Venezuela-South American opportunities—Husband & wife foreign jobs. Research Services, Suite 514-PS, Meramec Building, St. Louis 5, Missouri.

FREE Information—USA Overseas Jobs. High Pay, Transportation—Futures Unlimited, Dept. P, 215 West 34th Street, New York City 1.

JAPAN. Many hi-paying jobs available. Full, Complete details \$1.00. Walts, Box 903, C.P.O., Tokyo, Japan.

HOMEWORKERS! Average \$1.00 hourly producing for us. Numisales, 328-S 11th, West Bend, Wis.

FORMOSA jobs. Big pay, travel, house. Hundreds needed. Applications \$2. P. O. Box 270, Taipei, Formosa.

JOBS on Merchant ships. Big pay. Box 8391, Jacksonville, Fla.

JOBS galore in fabulous Florida! Men, women; skilled and unskilled. Contacts, \$2.00. Leroy Parker, P.O. Box 8425, Jacksonville 11, Florida.

JOBS Overseas! Janecek Development Co., 109 Hub Station, New York 55, New York.

YOUR own business—Suits \$1.50; Overcoats 65c; Mackinaws 35c; Shoes 12½c; Ladies' Coats 30c; Dresses 15c; Enormous profits. Catalog Free. Nathan Portnoy Associates, 2109-J Roosevelt Road, Chicago 8.

AGENTS—300% profit selling genuine gold window letters; stores and offices. Free samples. Metallic Sign Letter Co., 1217-E West Newport, Chicago.

FREE Sample! Beautiful Feather Pictures. Sylvial, Apartado 9036, Mexico 1, D. F.

GOLD or Silver letters, numbers. Windows, Doors, Trucks 1" to 6". 500% Profits—Free Samples. Atlas-U, 544 West 79th, Chicago 20.

IF you're interested in making money in selling, see the hundreds of exceptional opportunities in Salesmen's Opportunity Magazine. Send name for your copy, absolutely free. Tell us what you're selling now. Opportunity, 848 N. Dearborn, Dept. 18, Chicago 10, Illinois.

EVERY man a prospect. Request free sales kit showing line of belt buckles, individualized with customer's name and emblems also cap badges for trucking, bus, taxi, police, firemen. Choice 3000 emblems. Hook-Fast, Box 1425PS, Providence, Rhode Island.

TAKE over your area as a Service Distributor keeping retail stores supplied. Our nationally advertised 27-year-old line gives you 66⅓% mark-up. Tremendously successful moneymaking plan. Write K. O. Harris, c/o Novo, 1166 Milwaukee, Chicago 22, Illinois.

MEN & Women. 122% Profit selling Nationally Advertised famous Turtle Wax-Plastone Products for car and home. Finest quality made. Unconditionally Guaranteed. Super fast and easy to use. Amazing 30-second demonstrations. Products now sold in over 100,000 stores around the world. Choice restricted territories open. Large, continuous all-year earnings. Unlimited sales field. This is the first sales opportunity in 10 years with our company. Act Now! Send Today for Free details. Plastone, Dept. 02-7, Chicago 51, Illinois.

AMAZINGLY Easy Profits from exciting new Christmas Cards. 21-Card Assortment pays 75c per box—\$75.00 on hundred. Gift Bonuses besides. Outstanding selection Cards, Novelties, Free Imprint Album. Samples on approval. \$1.25 Gift Offer. Creative, 4401 Cermak, Dept. 511-J, Chicago 23.

ANYONE Can Sell famous Hoover Uniforms for beauty shops, waitresses, nurses, doctors, others. All popular miracle fabrics—nylon, dacron. Exclusive styles, top quality. Big cash income now, real future. Equipment free. Hoover, Dept. H-101, New York 11, N. Y.

NEW Bathroom Deodorizer. Hangs on wall. Banishes odors bathroom, kitchen. Lightning seller. Samples sent on trial. Kristee 50, Akron, Ohio.

SHOW Thrilling \$1 Values in newest Christmas Card Assortments, Stationery, Gifts. Keep up to 50c of every dollar. Big line; complete price range. No experience needed. Get Assortments on approval; Personal Portfolios Free; \$1 Gift Offer. Cardinal, 1400 State, Dept. 80-P, Cincinnati 14.

MAKE Money! Take big profit orders, famous Fruit Trees . . . including sensational discovery—Starkrimson Delicious Apple! Also Dwarfs, Shrubs, Roses, Vines. Sales outfit Free. Stark Bro's, Desk 30179, Louisiana, Missouri.

SIMPLE demonstration of our new invention amazes business and professional men. Write Frank Brown, Jr., Dept. PS-7, Box 97, Milan, Missouri.

\$500.00 EXTRA In Spare Time! . . . Plus chance to win Bermuda Cruise. Show friends Sunshine's outstanding nationally advertised Christmas cards. Box of 25 conventional size cards sells for only \$1.00 . . . \$1.25 for Slim Cards—worth much more—cannot be purchased in stores. Luxurious cards sell on sight. Sunshine offers other outstanding card values. Special fund raising plan for churches, clubs, etc. Write for details and samples on approval! Sunshine Art Studios, Inc., 59 Warwick, Springfield 1, Mass. (West of Rockies, write Pasadena 1, Calif.).

INCREASE income! Show friends wonderful box assortments of Christmas and all occasion greeting cards. Tremendous values. Low prices. Profits to 100% plus bonus. No experience necessary. Write for feature assortments on approval. Free Sample Album of Personal Christmas cards and stationery. New England Art Publishers, North Abington M-77, Mass.

RUN a spare-time greeting card and gift shop at home. Show friends samples of our new 1958 Christmas and all occasion greeting cards and gifts. Take their orders and earn to 100% profit. No experience necessary. Costs nothing to try. Write today for samples on approval. Regal Greetings, Dept. 86, Ferndale, Michigan.

WILL you wear new suits and topcoats without one penny cost and agree to show them to friends? You can make up to \$30.00 in a day even in spare time, without canvassing. J. C. Field & Son, Inc., Dept. B-1826, Harrison & Throop Sts., Chicago 7, Illinois.

NEW Invention patented low cost consumer product no competition million dollar potential. Write Austin Inc., 3440 Main, Hartford, Conn.

I'LL send you free stocking sample newest advancement in hosiery since discovery of nylon. Full-length; stays up without supporters; amazingly comfortable. Patented. Make money fast introducing to friends at 70c a pair less than Nationally Advertised price. American Mills, Dept. 653, Indianapolis, Ind.

BUSINESS of your own. Earning potential as high as \$40,000 annually. Issued on \$12,500 base. No merchandise to buy. Send for free explanatory booklet. Harrell & Company, Box 8-DD, Louisville, Ill.

EARN \$12,000 Yearly—only two sales daily. World's Best Seller. The Holy Bible. (Illustrated) Protestant or Catholic. Margareta's, P.O. Box 92, Hazleton 6, Pa.

EXCLUSIVE Line of Personal Initialed buckles, belts, cap badges, 3000 emblems. Hook-Fast, Dept. PS, Roanoke, Va.

EASY handwork makes fast-selling articles. Sample free. Sunmade Company, Brockton 64, Massachusetts.

BIG Profits—Stamp Social Security Plates Key Protectors. Sample—50c. Catalog Free. General Products, 188-PS State, Albany 10, N.Y.

\$1.00 PROFIT selling \$2.95 photo enlargement offer. Allen Studio, Reigler Bldg., Little Rock, Arkansas.

44 HIGH-GRADE SALESMEN

MAKE Extra Money. Cash commissions. Everybody buys easy-to-sell Advertising Book Matches. Union Label. Big variety—Glamour Girls, Scenics, Hillbillies. Powderhouse selling kit Free. Steady repeat business. No experience necessary. Superior Match Company, Dept. P-758, 7528 S. Greenwood, Chicago 19.

AD Matches! Sell amazing designs—10, 20, 30, 40, and 240-light book matches. Bigger spot cash commissions; every business a prospect. Low prices for high quality. Repeats. Start without experience; men, women; full, part-time. Buy nothing. Sales kit furnished. Match Corp., Dept. PS-97, Chicago 32, Illinois.

45 EDUCATIONAL & INSTRUCTION

COMPLETE Your High School at home in spare time with 61-year-old school. Texts furnished. No classes. Diploma. Information booklet free. American School, Dept. XB46, Drexel at 58th, Chicago 37, Illinois.

USED Correspondence Courses and Books sold and rented. Money back guarantee. Catalog free. (Courses Bought.) Lee Mountain, Pisgah, Alabama.

STUDY For Doctor's Degree of Psychology, Metaphysics and Divinity. Correspondence courses only. College of Divine Metaphysics, Dept. P-S, 2811 North Illinois, Indianapolis 8, Ind.

BE a Real Estate Broker. Study at Home. Write for Free book today. GI approved. Weaver School of Real Estate, 2018R Grand, Kansas City, Mo.

EARN While You Learn Auto and Diesel Mechanics. Master this top paying trade. Many graduates earn \$100 a week and up. Approved for Korean veterans. For free information write Dept. No. 262, Nashville Auto-Diesel College, Nashville 3, Tenn.

HIGH School diploma at home. Licensed teachers. Approved materials. Southern States Academy, Box 5344-PX, Station E, Atlanta, Georgia.

WANT a Diesel Job? New Opportunities to increase income. Higher Pay, More Money. We can help you Qualify. Tools Shop method home training. Write today! Diesel, Tractor, Heavy Equipment Division. Interstate Training Service, Dept. B-2, Portland 13, Oregon.

BOOKKEEPERS! Increase your earnings! Operate your own simplified "Dollar-A-Week" Bookkeeping and Tax Service. Full or spare time. Details Free. No obligation. Ellis, Box 203, Cedar Grove, North Carolina.

MASTER Watchmaking at home. Free sample lesson. Chicago School, 2328-WG Milwaukee, Chicago 47.

LEARN Another language at home, easily, quickly, naturally with Linguaphone, the World's Standard Conversational Method. You learn to speak French, Spanish, German, Russian, Modern Greek—any of 34 modern languages available on life-like conversational recordings. It's like living in another country. Complete language course available on free trial. Send for free book and details of free trial. No obligation. Linguaphone Institute, 1000 E. 11th St., Lincoln, Nebraska.

ENGINEERING Degrees earned through Home Study. Electronics, Electrical, Mechanical, Civil, Physics. When writing, specify course desired. Residence classes also available. Pacific International University (operating as a College of Engineering only at present), 5719-A Santa Monica Boulevard, Hollywood 38, California.

USED correspondence courses bought and sold. Catalogue free. C. B. Dudley, Broad Street, Athens, Georgia.

MATHEMATICS. Home Study Courses. UCSM, P. O. Box 5225, Philadelphia 26, Pennsylvania.

LEARN By Ear with Dormiphone. While you slumber, the amazing new scientific invention works for you. Revolutionary Dormiphonic tools give you a shortcut to learning languages, correct speech; memorizing facts, figures; relaxation, habit training. Saves your time, effort. So simple to use, children benefit. Used by educators, psychologists. Write today for fascinating free book. No obligation. Modernophone, Inc., 321-078 Radio City, New York 20.

HOW to cut hair at home. Photos, Instructions. Write L. Carter, 8450 E. Los Tunis Dr., San Gabriel, California.

WHY die—to go to heaven? You can have heaven here. My literature suggests how. David Ornsteen, Du Quoin, Ill.

WANTED more new writers of short stories, mysteries, articles. Learn at home for career or extra part-time income. Earn while learning. H. F. Wenderoth sold first story for \$240. Professional writers show you how. Send today for free lesson and book. Palmer Institute of Authorship, Desk UM-88, 1680 N. Sycamore, Hollywood 28, Calif.

EARN Degree. Free bulletin. Homestudy only. Midwestern Bible School, 1060 Broadripple, Indianapolis.

TEN months superior geographical course; valuable stamps weekly \$19.95. Surehelp, Box 345, Roanoke, Virginia.

LEARN Piano Tuning Easily At Home. Our Graduates lead field. Our 60th year. Free Booklet. Niles Bryant School, Dept. S. 3711 Stockton Blvd., Sacramento 20, California.

WE Pay \$3.50 lb. dried. Grow Mushroom. Cellar, shed and outdoors. Spare, full time, year round. We have 25,000 customers. Free Book. Washington Mushroom Ind., Dept. 180, 2954 Admiral Way, Seattle, Wash.

MATHEMATICAL Calculations made easy with Abacus. \$2.00 Postpaid with Instruction Book. Abacus Company, Box 2097, Torrance, California.

EARN College Degrees. Correspondence. Metropolitan University, Box 86, Glendale, California.

WELDERS earn big money. Easy to learn Arc—Gas—Automatic Welding. New equipment, low cost training in non-profit school. GI Approved. Free Booklet. Hobart Welding School, Box P-781, Troy, Ohio.

TRAIN as railroad station agent at home in spare time. Equipment furnished easy terms. Approved school. Guaranteed placement. Write Box 100, Marshalltown, Iowa.

PHYSICAL Therapy and Massage. Home Training. Practice privately or work with doctors and hospitals. Free Catalogue. National Institute, Box 4, 159 E. Ontario, Chicago, Illinois.

BECOME tax consultant, licensed home training. Union Institute, Hoboken 1L, N. J.

DEGREES, Diplomas, Certificates, through extension on any subject. Personal consultation and specific interest list, \$1.00. Box 296, Jacksonville, Illinois.

LEARN Real Estate—Study at home. Send for free catalogue. Midwest School of Real Estate, 68 North Chicago Street, Joliet, Illinois.

USED Correspondence Courses, Educational Books. Money-back Guarantee. Catalog 10c. (Courses Bought. Willard Bayles, 78 Courtright, Wilkes-Barre, Pa.

WAKE up your mind! Be what you desire! Smash worries, fears, indecisions, inferiority. Life-changing facts free. Write Box 1924-X, Louisville 1, Kentucky.

46 CONTESTS

WIN contest money. General Contest Bulletin gives hundreds of tips. Lists current contests, rules. Sample magazine 25c. General Contests, 1609-A East 5th, Duluth, Minnesota.

PRIZE Contests! Fabulous Home Income Opportunity! How and Where to Win Your Share! Latest Contest Books! Send Stamp! National Contest Bulletin, Box 2685-PS, Miami 16, Florida.

47 DETECTIVES

LEARN Civil and criminal investigation at home. Earn steady good pay. Institute Applied Science, 1920 Sunnyside, Dept. 00D, 101-1000 (3) Ill.

DETECTIVES—Work home—Travel. Experience unnecessary. Detective Particulars free. Write Wagoner, P-125 West 86th, New York 24.

DETECTIVE Training. Phillips Secret Service System, 1917-C North Kenneth, Chicago 39, Ill.

INVESTIGATORS wanted men, women join our association and represent us in your district. Write Box 434, St. John, N.B., Canada.

BE A Detective. Write for free details. State Age. National Detective Academy, Dept. A, P. O. Box 1082, Scottsdale, Arizona.

PROFESSIONAL Investigators Home Study. Badge, diploma, future. Box 41197, Los Angeles 41, California.

51 SPECIAL SERVICES

RESEARCH information services, write today, Harold Deck, 1610 Foxworthy, San Jose 24, California.

52 AUTHORS SERVICE

WANT Your Book Published? Learn how we publish, advertise, promote, distribute. Many successes. Free booklet PS. Vantage, 120 West 31, New York.

WRITERS: Book Manuscripts invited for publication on our cooperative plan. Greenwich Book Publishers, (Attn. Mr. Ibsen), 489 Fifth Avenue, New York 17, New York.

LOVE or action story plot outlines with surprise endings. Three for \$1.00. Elvet Bloomfield, 1821 Clay St., St. Joseph, Mo.

AUTHORS—Free Brochure tells how your book can be published, nationally advertised, promoted. Write today! Bardley Hall Press, Dept. PS, 363 Lexington Ave., New York City 17.

54 CARTOONING, SIGN PAINTING, CHALK TALKS

CARTOON Your way to success! Internationally known instructor, Raye Burns, will personally teach you to create original, salable cartoons at home. Cost of Course is very low. Write for free details. Raye Burns School, Box 3583-S, Cleveland 18, Ohio.

CARTOONISTS' Magazine. Lessons. Markets. Free Sample. Cartoonists, 2776 California Court, Lincoln 10, Nebraska.

YOU can Entertain with Chalk Talks. Catalog 10c. Cartoonist Balda, Oshkosh, Wisconsin.

56 RUBBER STAMPS & OFFICE SUPPLIES

3 LINES with pad 95c; Signature \$3.00. Economy, Box 829, Milwaukee 1, Wisconsin.

UP To 4 Lines \$1.00 with pad, including package plain name cards free. Printex, 120 Noble Ave., Roanoke 12, Va.

NUMBERING machines, stock rubber stamps, and staplers wholesale only. John Roby Co., 9045 16th S.W., Seattle, Washington.

GUARANTEED quality rubber stamps. Three lines \$1.00. Davies, P.O. Box 173, Clayton 5, Mo.

ATTRACTIVE. 3/4"x2 1/2" Three line pocket stamp 85c. Satisfaction guaranteed! Hildreth, 1047 Inner, Schenectady 3, New York.

THREE Line Metal or Plastic Pocket Case. \$1.00. Hand Stamps To 3" x 5". Mated Mailers, P.O. Box 494-2, Buffalo 5, N.Y.

INDEXED Cushioned 3 Lines \$1.00, 4 Or 5 Lines \$1.50. (Script, Print or Old English) Free Stock Stamp Circular. 1 Day Service. Youngers Stamp Shop, Princeton, Iowa.

THREE Line Office Type or Pocket Stamp \$1.00. W. S. Atherton, Box 61, Randolph, Massachusetts.

57 PRINTING, MULTIGRAPHING, ETC.

1,000 BUSINESS Cards. "Raised Letters" \$3.50. Samples. Pioneer, Island Park PS-7, New York.

100-6 3/4 ENVELOPES 100-5 1/2 x 8 1/2 Letterheads \$2.00. Al Hunt & his Printing Devils, McAlester, Oklahoma.

MIMEOGRAPHING, printing. Reasonable prices. Frajimidot, New Lebanon Center, N. Y.

100 6 3/4 ENVELOPES, 100 5 1/2 x 8 1/2 letterheads, printed any color, \$2.00. M. Fortney, R3, Dillsburg, Pa.

FREE Catalog. Postpaid Printing. D M Press, Sebastopol, California.

BUSINESS printing. Letterpress. Offset. Forms. Salesbooks. Mandelstam, 1128 Hyde Park, Chicago 15.

NAME, address on 100 envelopes \$1.00. Womble's, Siler City, N. C.

BUSINESS, Personal Printing—Labels, Rubber Stamps, Accessories. Illustrated Catalog, Free! Brose, 196-B, Clerk, Jersey

OFFSET Printing—24 hour service—\$6.75 1000. 8 1/2 x 11. National Letters, 251 West 42 St., New York 36, New York.

AMERICA'S finest quality printing, unbeatable prices. Catalog free, Steinbergen, 1274C Stebbins, NYC 59.

SMART effective printing. Moderately priced. Free literature. Holmes, 35 Bowdoin, No. Quincy 71, Mass.

500 3/4 x 2 1/4 FOUR line gummed stickers 50c. Red Border \$1.00. Moritz Printer, Saginaw, Michigan.

100 EACH 8 1/2 x 11 letterheads, 6 3/4 envelopes carefully printed. \$2.00 Postpaid. Race Printing, Hudson, New York.

58 PRINTING OUTFITS, SUPPLIES

DO your own printing. Save money. Simple rules. We supply everything. Print for others; good profit. Raised printing like engraving too. Have home shop. Details free. Kelsey Presses, V-8, Meriden, Conn.

PRINTING Presses, Type Supplies. Lists 3c. Turnbaugh Service, Mechanicsburg, Pa.

RUBBER Stamp making presses, hydraulic operated, electrically heated. Sizes 5"x8", 8"x12", 10"x15" starting outfits. All kinds supplies. Custom Manufacturing, 507 N. Jefferson, Springfield 2, Missouri.

MAKE Your Own self-molding rubber stamps and printing cuts. Plexirubber, Argyle 2, Wisconsin.

59 PATENT ATTORNEYS

C. A. Snow & Co.—S-427, Snow Building, Washington 1, D. C. Registered Patent Attorneys. Write for information.

INVENTORS: Without obligation, write for information explaining the steps you should take to secure a Patent. John Randolph, Registered Patent Attorney, 807 Victor Bldg., Washington 1, D. C.

INVENTION Record form free and "Patent Information Every Inventor Should Have." Carl Miller, Registered Patent Attorney, Woolworth Building, New York.

INVENTORS—Take these preliminary steps toward patent protection. Sketch and describe your invention. Sign, date and have this disclosure witnessed by two people who understand your invention. Have us make a preliminary search among U.S. patents already granted for similar types of invention. We report on the probable patentability of your invention and recommend your further course of action. Write for our instructive booklet, "Patent Protection for Inventors" and convenient "Evidence of Invention" disclosure form. Victor J. Evans & Co., 441-H Merlin Building, Washington 6, D. C.

INVENTORS—If you believe that you have an invention, you should find out how to protect it. The firm of McMorro, Berman & Davidson is qualified to take the necessary steps for you. Send for copy of our Patent Booklet "How to Protect your Invention" and "Invention Record" form. No obligation. McMorro, Berman & Davidson, Registered Patent Attorneys, 143-M Victor Building, Washington 1, D. C.

INVENTORS: Protect your invention. Joseph Lindecker, Registered Patent Attorney, 7839 Kolmar, Skokie, Illinois.

INVENTORS: Learn how to protect your invention. "Patent Guide" containing detailed information concerning patent protection and procedure together with "Record of Invention" form will be promptly forwarded to you upon request—without obligation. We are registered to practice before the U.S. Patent Office and prepared to serve you in the handling of your patent matters. Clarence A. O'Brien & Harvey Jacobson, Registered Patent Attorneys, 82B-G District National Building, Washington, D. C.

"INVENTOR'S Guide" and "Record of Invention" free on request. Frank B. Ledermann, 154 Nassau Street, New York City.

60 FOR INVENTORS

INVENTORS—Send for free Patent Information book and Inventor's Record. Registered Patent Attorney, Associate Examiner, Patent Office 1922-1929; Patent Attorney & Advisor, Navy Department 1930-1947. Gustave Miller, 78PSI Warner Building, Washington 4, D. C.

INVENTORS, if you have an invention for sale, patented or unpatented, write Institute of American Inventors, Dept. 30A, 635-F St., N.W., Washington 4, D. C.

INVENTORS—If you believe that you have an invention, you should find out how to protect it. The firm of McMorro, Berman & Davidson is qualified to take the necessary steps for you. Send for copy of our Patent Booklet "How to Protect Your Invention" and "Invention Record" form. No obligation. McMorro, Berman & Davidson, Registered Patent Attorneys, 143-L Victor Building, Washington 1, D. C.

INVENTIONS wanted now by my Manufacturer—Clients. Patented. Unpatented. Write Gilbert Adams, Patent Broker, 80-B Wall Street, Financial District, New York

INVENTION Record form free and "Patent Information Every Inventor Should Have." Carl Miller, Registered Patent Attorney, Woolworth Building, New York.

INVENTORS: Learn how to protect your invention. "Patent Guide" containing detailed information concerning patent protection and procedure together with "Record of Invention" form will be promptly forwarded to you upon request—without obligation. We are registered to practice before the U.S. Patent Office and prepared to serve you in the handling of your patent matters. Clarence A. O'Brien & Harvey Jacobson, Registered Patent Attorneys, 82A-G District National Building, Washington, D. C.

INVENTORS: Without obligation, write for information explaining the steps you should take to secure a Patent on your invention. John Randolph, Registered Patent Attorney, 806 Victor Bldg., Washington 1, D. C.

PATENT Drawings. Let us make them for your inventions. 35 Years experience. Patent Service Associates, Haverhill, New Hampshire.

INVENTORS—If you consider your invention to be something of importance, take steps to protect it with a United States Patent which gives you the right to exclude others from making, using and selling your invention as claimed. "Patent Protection for Inventors" outlines steps to take to secure patent protection. Mailed promptly without obligation. Victor J. Evans & Co., Merlin M. Evans, Registered Patent Attorney, 442-H Merlin Building, Washington 6, D. C.

INVENTORS Don't sell your invention Patented or Unpatented until you receive our offer, write Cowgill, Box 298, Marion, Ohio.

"HOW to sell your invention" Complete format 50c. Product Research, Box 181, Arlington, Virginia.

HIGHEST Cash & Royalties paid for Ideas, Patents, Manufacturers, Investors listing. Write Inventors Creative Service, 354 South Spring, Los Angeles 13, California.

MONEY made with inventions! Tested procedure. \$1.00—ABC Inventions, Box 402, West Covina, California.

INVENTIONS protected without Patents. Tekservice, 282 Woodcliff Station, North Bergen, N.J.

PATENT Searches \$6.00. 48-hour airmail service. Invention Protection forms free. Write Patent Engineering Service, 711 14th Street N.W., Washington 5, D. C.

PATENT Searches \$6.00. 48-hour service. Free Invention Protection forms. Write Raymond L. Smith, Patent Searcher, 620 Sheraton Building, Washington 5, D. C.

PATENT Searches including copies of nearest patents. \$6.00. Reports airmailed within 48 hours. More than 100 registered patent attorneys use my service. For Free invention protection forms, write Miss Ann Hastings, P.O. Box 176, Washington 4, D. C.

61 INVENTIONS WANTED

INVENTIONS wanted. Patented; unpatented. Tremendous Manufacturers lists. Global Marketing Service, 2420 77th, Oakland 5, Calif.

INVENTORS: Hundreds of manufacturers have requested our assistance in locating marketable new products. Complete information free. Institute of American Inventors, Dept. 30C, 635-F Street, N. W., Washington 4, D. C.

INVENTORS—Do you want to sell or license your invention on cash or royalty basis? Write Kessler Corporation, 77IW, Fremont, Ohio.

INVENTORS Don't sell your invention Patented or Unpatented until you receive our offer, write Cowgill, Box 298, Marion, Ohio.

WE market worthwhile inventions. Patented, unpatented. Harvey Engineering, Cambridge, Maryland.

INVENTIONS Wanted: "Patented"—"Patent Pending". 27 years experience Promoting Inventions. National Service Bureau, 3122 Meramec, St. Louis 18, Mo.

INVENTIONS wanted now by my Manufacturer—Clients. Patented. Unpatented. Write Gilbert Adams, Patent Broker, 80-R Wall Street, Financial District, New York City.

63 MANUFACTURING

BIG money in foam plastics. Home-manufacture toys, cushioning, mattresses, life preservers. Introductory kit containing chemicals, hand mixing instructions, our bulk chemical prices, uses. Send only \$3.00 with name, address to: "Kit," Foam Products, Box 427, Warner Robins, Ga.

64 MODELS, MODEL SUPPLIES

ROCKET building for students, 80 pages, \$2.10, written parental consent necessary, 3262 Castera Avenue, Glendale

SHIP and yacht model fittings; blueprints. Send 35c for Illustrated catalog #29 listing hundreds of items. A. J. Fisher, 1002-2 Etowah Ave., Royal Oak, Michigan.

SHIP Models. Most complete line in New England. Kits, fittings, plans, books, tools, engines, motors. 1958 illustrated catalog 35c. James Bliss and Co., Inc., Dept. PS, 342 Atlantic Avenue, Boston 10, Massachusetts.

MODEL Ship Kits, Fittings and Plans including Clippers, Trawler, Fishermen, Frigates, Privateer, etc. Towboat of 1900 for HO Gauge \$3.95. New 1958 Catalog 25c. Model Shipways, Box 85, Bogota, N.J.

LIONEL Trains. Big Discounts. Bulletin Free. Catalog, 25c. Mack Brothers, 2041 Chicago Ave., Chicago 22.

ROCKETS. 4 different plans. High-flying. Inexpensive. \$1. Rocketry, Spencer, Iowa.

MINIATURE Engines: Gasoline and Steam. Build Them on Your 6" or 9" Lathe. Illustrated Catalog, Listing Castings, Blueprints, Fittings, etc., Only 10c. Octura Models, P.O. Box 536-PS, Park Ridge, Illinois.

SAFE rocket materials. Samples 25c. Central Rocket Company, Box 221, Wau-paca, Wisconsin.

POWER models. Unusual steam, gasoline and traction engines, fittings, metals. "Truscale" pipe fittings, elbows, tees, valves, etc. Comprehensive catalog \$1.00. Charles Cole, Ventura, Calif.

ROCKETS—Complete plans, 1 & 2 stage, 3/4" to 3 1/2" diameter. See ad page 47.

"ST" Steam Engine Castings, Fittings Catalog 15c. Ship Models Ltd., 186 Summer, Andover, Mass.

65 HOME CRAFTSMAN

WOODWORKING and Cabinetmaking course for beginning and advanced home craftsmen. Only complete low-cost home training program available. Write for free booklet. Interstate Training Service, Dept. G-2, Portland 13, Oregon.

89 JIG Saw Patterns. Beautiful shelves, Ornaments, Novelties. Plus "How Where to Sell." \$1.00. Mastercraft, 74S, 7041 Olcott, Chicago 31, Illinois.

FREE "Do-It-Yourself" Leathercraft Catalog. Tandy Leather Company, Box 791, Z26, Fort Worth, Texas.

STYLECRAFT "Pretraced" leather kits. Handbags, Billfolds, Filigree Belts. Patterns on leather. Just carve, assemble and lace. "Pre-carved" kits also available. Send 25c for catalog, free folder. Refunded first order. Apache Leather Company, 2804 E. Washington St., Phoenix, Arizona.

MAKE cash from your workshop. 2150 actual size artist-drawn patterns. Free catalog. Craftplans, 1322-B Wabash, Chicago 5.

ANY circular handsaw cuts perfect angles, with Universal jig. Free folder. Barnes Tool Service, Pulaski, Tenn.

SHELLCRAFT supplies, cut shells, metal findings, rhinestones. Illustrated catalog 25c. The Shell Mart, 870 1st Ave. No., St. Petersburg 1, Florida.

SQUAREKNOTTERS: Make belts, handbags, lanyards, dog leashes, etc. Special offer! Beginner's book, catalog and quality cord samples 25c. P. C. Herwig Co., Dept. 71-P7, 39 Henry St., Brooklyn 1, New York.

KNOCKDOWN cedar chest and lumber, free price list. Bedford Lumber Company, Shelbyville, Tennessee.

LEARN Art Metalcraft and jewelry making. Complete, inexpensive, home training course now available. Special tools and materials furnished. Write for free booklet. Interstate Training Service, Dept. L-2, Portland 13, Oregon.

66 DO IT YOURSELF

AIR Conditioners, Home, Automobile. See Kool Engineering Ad Page 203.

FAN Kit—Ideal for window or attic exhausting unit in home or business. Belt-driven. All necessary parts furnished, except motor and lumber for frame. Three sizes available: 20"—\$12.90; 24"—\$14.90; 30"—\$17.90. Direct Cash Orders shipped prepaid. 50% deposit on C.O.D. orders. Offer good in U.S. only. 1/4 H.P. motor for any size kit—\$17.70. Send for free catalog. Kloppenborg Fan Shop, 211 Marquette, Davenport, Iowa.

SWIMMING pool and filter built for \$450. Plans, photos, instructions \$1.00. William Wurtz, Box 63, Paramus, N. J.

JALOUSIES save 50%. Details. Installation Photographs, Free! Alumalife Industries, Hammonton, N. J.

MAKE your own guitar. We have plans, book, woods, tools. Free list. Wildwood, 510 East 11th Street, New York 9, N.Y.

FREE sun power can work for you. Investigate. Shelby Industries, Box 573-D, Bellflower, California.

BUILD lighted picture frames. Plans 25c. Woods, Wyoming 23, Pa.

HOT Water Aplenty \$1.00 from your present hot water heater yet no fear of scalding. Simple Instructions \$1.00. Hot Water, Box 35236, Los Angeles, Calif.

67 OLD GOLD, JEWELRY, WATCHES, ETC.

USED and new watches \$2 up. Free List. Southern Watches, 5-PS So. Wabash, Chicago 3.

COSTUME Jewelry Supplies. Settings, Rhinestone, etc. 88 page illustrated catalog, 25c. Milady, Box 1328 G.P.O., New York City (1).

HIGHEST Cash For Old Gold, Broken Jewelry, Gold Teeth, Watches, Diamonds, Silverware, Spectacles, Platinum, Mercury. Free information. Rose Refiners, Heyworth Bldg., Chicago 2.

FREE Illustrated Catalog. Costume Jewelry Parts, Supplies. Folsom's, Box 52, Medford 55, Massachusetts.

POCKET alarm watches. Remit \$14.95 for sample. Refundable. Tatulis Company, Main Street, Listowel, Ontario, Canada.

10 SWISS Watches \$18.00. Catalog 25c. Berkowitz, 1150 Castlehill, New York 62.

69 FOR THE HOME

FOAM rubber furniture cushions—Factory seconds 50% discount. Free catalog. Perma-Foam, 390-A Nye Ave., Irvington, New Jersey.

CESSPOOLS, septic tanks, outdoor toilets, cleaned, deodorized without digging, pumping or moving. Free details. Chemical Cesspool Cleaning Company, Boston 34, Massachusetts.

YOUR name engraved on colonial style brass nameplate. \$2.00. Engravers, Box 56, Saugerties, N. Y.

70 OF INTEREST TO WOMEN

MAKE \$25 to \$35 weekly addressing envelopes. Our instructions reveal how. Glenway, Box 6568, Cleveland 1, Ohio.

DRESSES 24c; Shoes 39c; Men's suits \$4.95, trousers \$1.20. Better used clothing. Free Catalog. Transworld, 164-T Christopher, Brooklyn 12, N. Y.

HOUSEWIVES Wanted! Big money. Spare or full time cake decorating and candy making. Turn your kitchen into a gold mine. Complete instruction course, learn and earn at home. Write for free facts: Candy & Cake, Dept. 111, 3209 W. Olympic, Los Angeles 6.

"LEFTY" shears for Southpaws 7" \$3.95. Guaranteed. Impic, 2916 Fillmore, San Francisco 23, California.

CUTE Lavender Sachet Pin Cushion \$1.25. Corante, 6316 Santa Monica, Hollywood 38, California.

BIG Profits Making Flowers. Beginners Outfit \$1.00. Floralcraft, Box 6524, Phoenix, Arizona.

SEND no money, just your name, for 21-Card Assortment of beautiful Christmas Cards on approval. Show sensational \$1 value to friends, neighbors. \$75.00 to \$500 possible between now and Christmas. We'll include free catalog with 76 other money makers; also free samples popular name-imprinted cards. Wallace Brown, 11 E. 26th St., Dept. H-242, New York 10.

KNITTEN Kitten home knitting machine, over 5000 stitches per minute. Makes sweaters in 2 hours. Become our agent, make good commissions, we finance. Knitten Kitten, 9045 16th Ave., S.W., Seattle, Washington.

WANT extra cash? Send your name for money-making Christmas card samples on approval. Showing them to friends pays you as much as 50c to \$1.25 profit per item—\$150.00 easy! Free Personal Album; 30th anniversary gift offer. Midwest, 1113 Washington, Dept. 502-S, St. Louis 1, Mo.

WE Pay \$3.50 lb. dried. Grow Mushrooms. Cellar, shed and outdoors. Spare, full time, year round. We have 25,000 customers. Free Book. Washington Mushroom Ind., Dept. 181, 2954 Admiral Way, Seattle, Wash.

\$200.00 MONTHLY Possible, Sewing Babywear! No house selling! Send stamped, addressed envelope. "Cuties," Warsaw 14, Indiana.

71 FOR SALE MISCELLANEOUS

SALT and pepper set. Authentic reproductions of hand crafted watches from the Gay Nineties era. Gift packaged in a tooled leather-like album case. \$2.19 postage prepaid. Ken-All, Dept. SP, 171 West Center St., Southington, Conn.

READ, True Tales. Adventure, Pirates Buried Treasure, with Map of Florida's Islands. Send \$1.00. Jimmy Ray, Palmetto, Florida.

BOOMERANGS from Australian Aborigines \$2.95. Jones, 25 Panoramic, Balwyn, Victoria, Australia.

72 WANTED TO BUY

JOB Lots—Discontinued Patterns—Inventions—Cash Waiting. Edward Foote, Glastonbury, Conn.

QUICKSILVER, platinum, silver, gold. Ores analyzed. Mercury Terminal, Norwood, Massachusetts.

TOP prices paid for old copies of Popular Science—need only issues from period 1890 to 1915. If books are complete, even though condition is not perfect, please write us and describe what you have. Do not send the issue until you hear from us. Write to Box 308, Tuckahoe, New York.

73 WEARING APPAREL

HANDMADE Cowboy Boots, Wellingtons, Jodphurs. Free Catalog. Hall Boots, Box 7302, El Paso 11, Texas.

74 RAZOR BLADES, SHAVERS

100 RAZOR blades only 88 cents. Double edged surgical steel. Guaranteed. We pay postage. No C.O.D. Zimmerman, Box 225, Saxton, Pa.

UNCONDITIONALLY guaranteed. Double your safety razor shaves. No sharpening. Send one dollar today. CB Sales, Box 76, San Gabriel, California.

FREE sample blade, from Germany. Revolutionary accomplishment. First time in USA. Paul Weil, Dept. S, Box 157, New York 31.

75 TATTOOING SUPPLIES

LEARN profitable, fascinating Tattooing. Illustrated information \$1.00. Zeis, 728-B Leslie, Rockford, Illinois.

77 GEIGER COUNTERS & TREASURE FINDERS

MONEY . . . In Hidden Treasure. Find It . . . With a Goldak Treasure Finder. Send For Free Literature on Complete Line of Mineral & Metal Locators, Underwater Detectors, Etc., Priced as Low as \$64.50. In Celebration of Its 25th Year. Goldak Co. Introduces New Transistor Instruments for Greater Sensitivity, Less Weight, Low Cost Flashlight Batteries. Write for Information Today! Goldak Co., 1540 W. Glenoaks Blvd., Glendale, Calif.

FIND lost or hidden treasures with new transistor metal detector, underwater metal detectors, scintillation counters, etc. Free literature. Gardiner Electronics, Dept. 1, 2545 E. Indian School Road, Phoenix, Arizona.

TREASURE! Coins, Bullion, Cannon Balls, Silverware, M-Scope Locators find them. Newest features. Terms. Catalog. Fisher Research, Dept. C-2, Palo Alto, California.

TRANSISTOR Treasure Finders, Geiger Counters. Latest Underwater Detector. Free Catalog. Sierra Scientific PS-23, 5415 York, Los Angeles 42, California.

GOLD, silver, metal detectors. Geiger counters for uranium. Violites. Sensational new fully guaranteed models. None finer. Information free. Detectron Corp., 5528 Vineland Ave., North Hollywood, Calif.

FREE Literature—Lightweight, guaranteed Metal Detectors. Geiger Counters and Mineralights. Kits and Assembled Models. Electronic Applications, Dept. S, Box 8, Arlington 10, Virginia.

78 WATCH REPAIRING

WATCH and clock repairing books. Free catalog. North American, 2320-BU Milwaukee, Chicago 47, Illinois.

WATCHMAKERS'—Jewelers' Supplies, Instructions. Catalog 25c. Bengal Wholesalers, Culver City, California.

WATCHES overhauled. Regular \$5.95. Automatics \$7.95. Others, request prices. Nonreparables returned. P. deGruyter, 94-A Jasmine, Shaw AFB, South Carolina.

79 MISCELLANEOUS

BUY Wholesale! 25,000 Nationally Advertised Products. Get Amazing Dealer Catalogs. Complete Details Free. American Wholesalers, 1841-E Levee, Dallas 7, Texas.

WRITE For Free Catalog. New Government Surplus—GI Self-Instruction Books. Value over \$7 each. Mathematics, History, Foreign Languages, Accounting, Farming, Automechanics, Establishing New Business, Etc. \$1.00 each postpaid. Choose from over 60 courses. Sual Co., Dept. M, Elsinore, California.

PICTURE Post Cards Made from Your Photograph. 1000—\$12.00. Raum's, 4154 Fifth Street, Philadelphia 40.

ORNAMENTAL Iron designs. Book of 1700 beautiful, practical designs for railings, columns, etc. Free literature. Cunningham, 3881 South 3200 West, PS, Salt Lake City, Utah.

SECURE your future with an exclusive franchise. Fascinating, profitable opportunities reported nationwide. Request details. National Franchise Reports SP-528, 333 North Michigan, Chicago 1.

FREE catalog—unusual gift items. Myco, Box 25-PS, Runnemede, New Jersey.

BOOKS on antiques and their prices! Free circular! E. Warman, Publisher, Uniontown, Pa.

FREE Literature — Make Big Money Raising Fishworms and Crickets. Carter Farm-12, Plains, Ga.

SNOW Cone Machines. All Prices And Sizes. Special For Grocery Stores. Box 7803, Dallas, Texas.

WE Pay \$3.50 lb. dried. Grow Mushrooms. Cellar, shed and outdoors. Spare, full time, year round. We have 25,000 customers. Free Book. Washington Mushroom Ind., Dept. 182, 2954 Admiral Way, Seattle, Wash.

CIGARETTES—Improved roller makes 20 for 9c. Facts free. Moberly, Box 811, Owensboro, Kentucky.

RECEIVE—Magazine Samples, Mails, Catalogues, Offers From Everywhere. Get. Listed 25c. Rorick's, Cincinnati 26, Ohio.

SAVE time—6 seconds, patch is on. Mend while you iron. White. 180"x1 1/4"—\$1.00. May's, Box 4214, Sta. B, Spokane 31, Washington.

SUPERLIFE supplement, fine food for fatigue. Guaranteed results. Trial \$3. Superlife, Broadway, Virginia.

79A WESTERN MERCHANDISE

FREE Catalog: Western Wear, Saddles, Boots, Leather Supplies. Silver Spur, Box 1785-PP1, Fort Worth, Texas.

80 PERSONAL

PAY Your Bills Now. Borrow \$100.00 to \$600.00 Cash by mail. Easy, quick, private. Repay in small monthly installments over 20 months. Your payments may run 1/2 less than now; have money left over to spend. Loan Order Blank mailed Free in plain envelope. Advise amount needed. State Finance Co., 323 Securities Bldg., Dept. G-227, Omaha 2, Nebr.

MEXICAN Legal Matters. A. Espejo, Box 217, Tijuana, Mexico.

VITAMINS—Save 45%. Buy Direct. All Formulas. Free Catalogue. Vitaspec, Box 4435-Y, Philadelphia 40 Pa.

"YOU Can Find Out!" Confidential information developed, any matter, person, anywhere. Officially Licensed. Established 1922. Equitable Service Bureau, 15 Maiden Lane, New York.

ATLANTIC City, New Jersey. Remailing 25c, Classifieds \$1.00. Burnham, 4330 Atlantic Avenue.

LETTERS remailed 20c, \$2.00 monthly. Vincent J. Daczynski, 6445 232 St., Bay-side 64, N. Y.

LOANS By Mail. Borrow \$50 to \$500 for any purpose. Employed men and women over 25, eligible. Confidential—no co-signers. Up to 2 years to repay—low monthly payments. Supervised by Nebraska Banking Department. Loan application sent free in plain envelope. Give occupation. American Loan Plan, City National Bank, Dept. PS-7, Omaha 2, Nebraska.

GATEWAY to the Adirondacks and Canada. Remails 25c. Carole, 1518 Kemble St., Utica, N. Y.

FREE! "Magic" auto emblems. Chrome-finished. \$3.50 value. Masons, Shriners, Consistory, Grotto, Doctors, Dentists. How? Write New Era Specialties, Melbourne 2, Fla.

ADULTS: interesting samples 20c. Per-sil, 436 N. Y. Ave., Brooklyn 25, N. Y.

WHATEVER you want to know answered in documented report. Confidential. Details free. Research Reports, Box 1108, Atlanta, Georgia

LOSE weight at the David Stry Vegetarian Health Ranch, Melbourne 2, Florida.

REMAILS 25c. Monthly, \$3. Chicago Mail, 509 North Union, Chicago 10, Ill.

MAGIC Sex Indicator reveals innermost secrets. Develop exciting "Personal Power." Free details! Dimensional Enterprises, Sedona 5, Arizona.

LETTERS Remaild 25c. Confidential. 34 Ardmore, West Hartford 7, Conn.

ADULTS—Receive "Interesting Mails." Send 25c. Bentz (Desk—S/95), Chatawa, Mississippi.

INFLUENCE others. A magnetic voice the greatest asset for charming personality and to command interest. Voice sounded through magnetic nerve centers acquires improved qualities, charms others. Easy method, no drills. Send only \$2.00 (C.O.D. \$3.00) or request free information. Waldemar Vervuurt (Quality Systems), P. O. Box 7036, Miami 55, Fla.

LETTERS remailed 25c. Jerry Love, 1419 E. 83rd, Los Angeles 1, Calif.

SUPER memory overnight! Success guaranteed! Bijou, Box 1727-S, Hollywood 28, Calif.

MY fourteen months of remailing, this book has all dates of letters remailed, the cost and money received. Copyright 1958. \$2.00 postpaid. Ross Hancock, 83 Bellhaven Rd., Toronto 8, Canada.

"HOME brewed wines, etc." Complete book \$1.00. ABC Publications, Box 849, San Francisco 1-ED, California.

REDUCE! Safe! Sure! Easy! Write AC-2, 760P Caop Street, San Francisco 10, California.

ENGLISH remails, 25c. Airmails 50c, Stamps included. BCM/203, London, W.C.1.

"RULE Others with thoughts." Full course—\$3. Adults. Controversial; satisfaction or refund. Clarion, 846-S6 Sunnyside, Chicago 40.

MAIL Received—Forwarded. \$3 Month. Hedgpeth, Box 830, Alhambra 24, Calif.

PRAYER that works! Attract peace of mind, happiness, abundance through new interpretation of Bible. Nothing else like it. Solves all problems. Write for free folder. Ontology Homewood 146-A, Ill.

"COBRA. Self-defense street-fighting tricks." Designed to help peaceful adults. \$2. Gaucho, 846-S6 Sunnyside, Chicago 40.

MEXICAN Law Practice Attorneys. 1203 Arizona Avenue, El Paso, Texas.

SOUTHERN Calif. opportunities galore. Sunday classified \$1.00. Letters remailed 25c. Post Cards 10c. 14 scenic views \$1.00. 12 Glamorous Hollywood Stars Homes \$1.00. Remaild free. Gerard, Box 2489, Long Beach, Calif.

LETTERS promptly remailed from Mexican border. 20c. Also, free German synthetic gem catalogue. MexTex, El Paso, Texas.

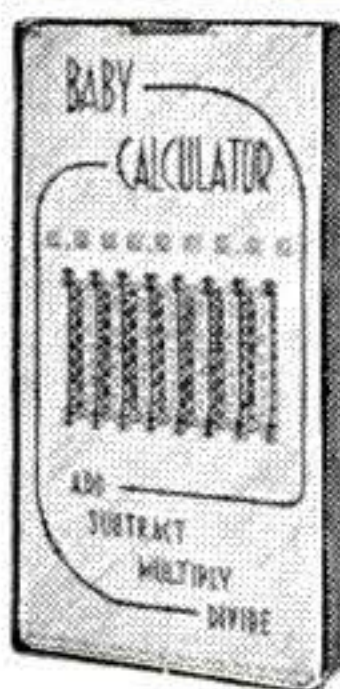

WORLD'S LOWEST PRICED ADDING MACHINE

Counts up to 999,999,999
IDEAL FOR BUSINESS AND PERSONAL USE—GUARANTEED ACCURATE.
 Not a toy. Operates with only a finger flick. Adds, subtracts, multiplies, divides. Counts up to one billion. Pays for itself over and over. Ideal Gift—for Business, Income Tax and School use.
MONEY BACK GUARANTEE. Send name and address. Pay postman only \$2.95 plus postage. Beautiful rich-looking Leatherette Case included at no extra cost. Money back in 10 days if not delighted. AGENTS WANTED.
CALCULATOR MACHINE CO., (Mfrs.)
 Box 126 Dept. X-82, Huntingdon Valley, Pa.

Vest Pocket Size
FREE TRIAL

\$2.95

\$3.04 in Penna. Incl'g. 3% Tax

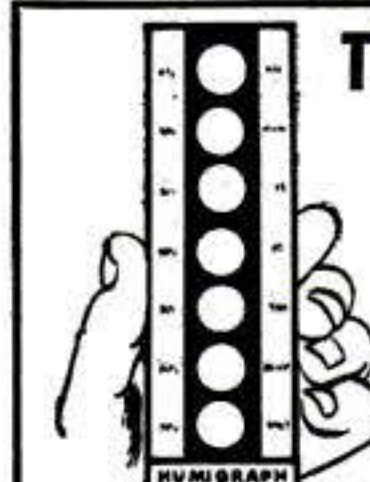

TELLS HUMIDITY AT A GLANCE!

If you can tell the difference between pink and blue, you can read humidity from 10% to 80%! Hundreds of thousands of Humigraphs now in use, in industry, science, military installations! Usable many months. Useful, instructive, accurate, low cost.

Pack of 5 Humigraph Cards and brochure.....postpaid in U.S. only **\$1.00**

SCIENCE MARKETS, Dept. 200, 7068 N. Clark, Chicago 26, Ill.

GIANT 6 FOOTERS 59¢



Great Fun for Kids and Adults at Beach, Playground or Water Sport. Inflate to Giant 6 ft., 21 ft. Round, with air or Gas. Flying Advt. visible for miles. Terrific for attracting crowds at Openings, Fairs, Roadside Stands, Gas Stations, Sport Events. Use as Water Markers and Buoys. Made of genuine Neoprene Rubber for extra durability. Surplus, Never Used. Sold at fraction of cost. Add 10¢ handling cost per order. 59¢ ea., 2 for \$1.5 for \$2. 12 for \$5. Huge 10ft., \$1 ea. Colossal 30 ft., \$5.00 ea. No C.O.D.'s.

33 2nd Ave., Dept. G-2307
 New York 3, New York

NOVEL MFG.

ROCKET PLANS

BUILD YOUR OWN 1 and 2 Stage Large and Small

Our 12 page, illustrated booklet includes:

- Complete Rocket Construction
- Various Solid Fuel Mixtures
- Electrical Firing System
- Launching Platform
- Principles of Rocket Propulsion And Stability

How to Measure Firing Height Safty Rules

And many other features for 3/4 to 3 1/2 in. diameter rockets. Our plans are designed for high altitude performance

All of this and more in one book. **SATISFACTION GUARANTEED**
 Immediate Delivery

NOT A TOY!

Rockets Dept. D-8
 1311 Rosewood Dr.
 Columbia, S. C.



Only \$1.00

TRIUMPH

**GIVES YOU
EXTRA POWER
AND
ECONOMY!**

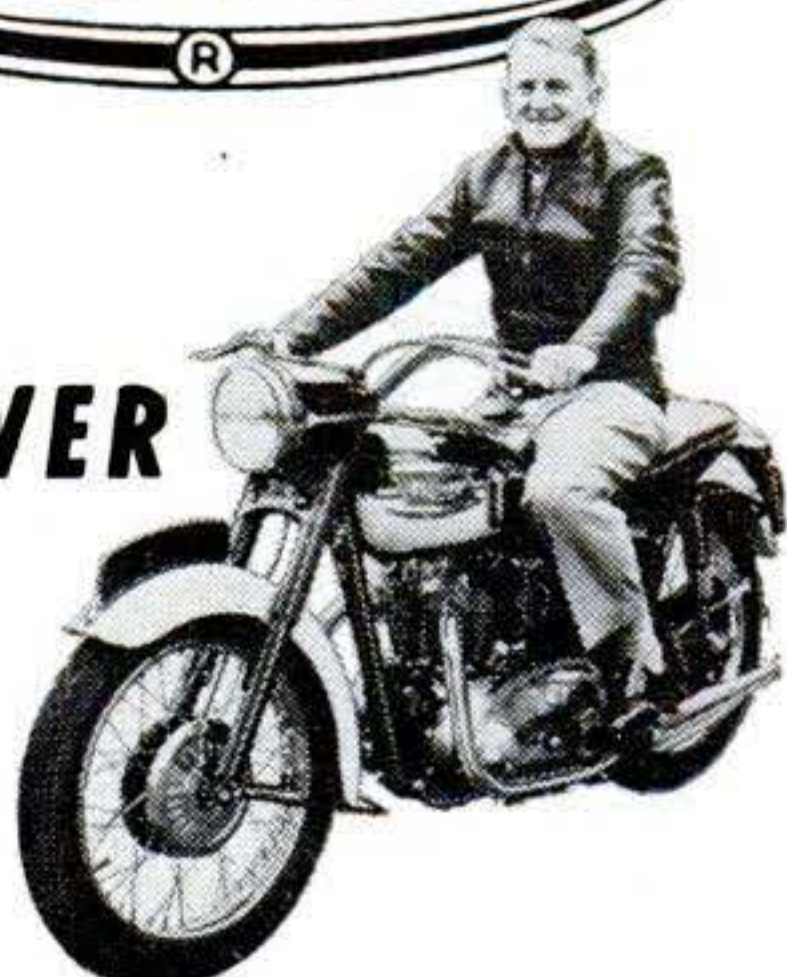

You step right into the lead with Triumph—America's top-selling OHV motorcycle. Here's a fun-machine that is specially engineered for maximum performance, highest economy. Triumph is tops in every department . . .

speed, maneuverability, handling ease and economy. Averages from 75 to over 100 m.p.g. Available in a wide range of models and brilliant color combinations. See your nearest Triumph dealer now for free demonstration ride.

SEND COUPON TO NEAREST ADDRESS

JOHNSON MOTORS, INC., 267 W. Colorado St., Pasadena 1, Cal.
THE TRIUMPH CORPORATION, Towson, Baltimore 4, Maryland

FREE! — Please send me without obligation a copy of the new, full color 1958 Triumph catalog.

Check here for name, address and telephone number of nearest Triumph dealer. Dept. L

NAME:.....AGE:.....
STREET:.....
CITY:.....STATE:.....
TELEPHONE NUMBER:.....

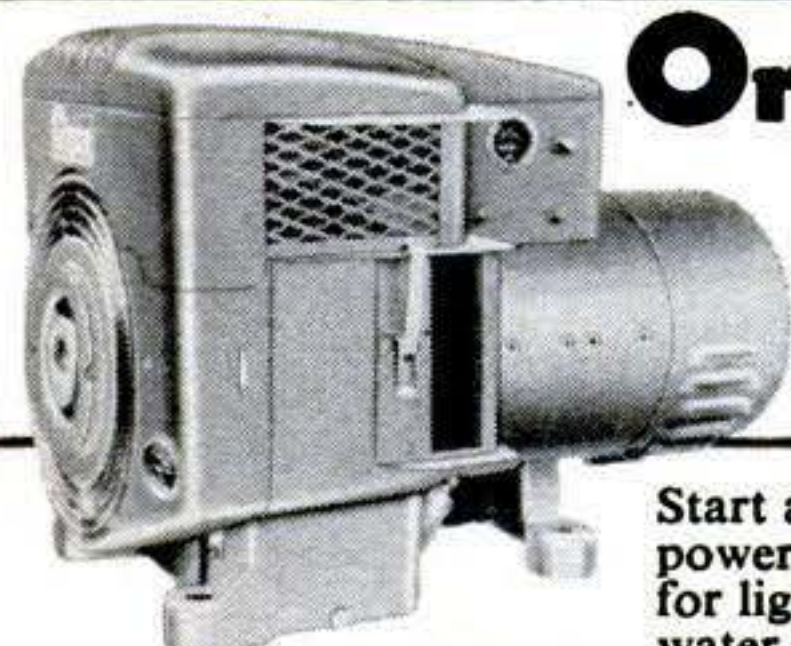

Onan Emergency Electric Plants

Start automatically when highline power is cut off, supply current for lights, heating system, freezer, water pump, stove, all appliances and machines. Prevents losses and hardships. Plant stops automatically when power is restored. Compact, easy to install. 500 to 150,000 watts A.C. Priced from \$319.00.

Write for Free Folder

**PORTABLE
MODELS**

500 to 10,000 watts. Supply plug-in power anywhere!

D. W. ONAN & SONS INC.
3606A UNIVERSITY AVE. S. E. • MINNEAPOLIS 14, MINN.

250 POWER

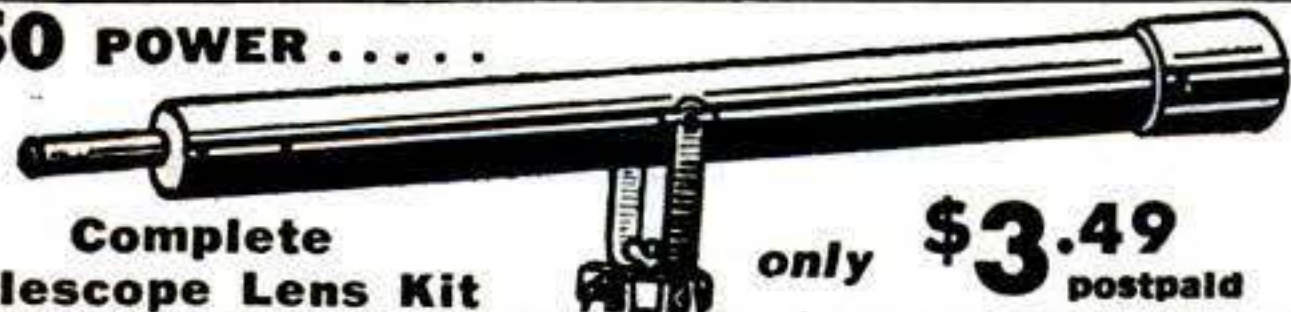

Complete Telescope Lens Kit only **\$3.49** postpaid
Conquer Space, Explore the Universe, Planets, Moon craters, New Stars, etc. Complete Lens Kit consists of 80 inch focal length ground and polished objective lens, eyepiece lenses for 50 POWER, 100 POWER, 150 POWER, 200 POWER, 250 POWER, and all necessary lens fittings. Easy to make from simple step by step instructions. (Tripod and mount not included.) Money back guarantee.

BUSSE SALES CO., Hartford, Conn., Dept. PS-69

NEW MISSILES IN MINIATURE

COMPLETE MISSILE UNIT in metal with HIGHLY DETAILED ACCURACY
HAWK I - A low-level anti-aircraft missile designed for defense against enemy dive-bombing and strafing attacks. The set includes mobile triple launcher with 3 Hawk missiles, a tractor transporter carrying 3 more Hawks, a mobile radar unit and 4 missile men. This is only one of several missile units being offered by AUTHENTICAST. Send for catalog showing many others plus their famous tanks, ships and planes! Only 35¢

COMET METAL PRODUCTS CO., INC.

by AUTHENTICAST



HAWK I #5193 \$5.00

RICHMOND HILL 18 NEW YORK N.Y.



TEN delightful, exciting MOVIES

FANTASTIC OFFER
ALL TEN MOVIES **\$2**
IN 8mm FOR ONLY
(16mm—\$4)

The movie buy of a lifetime! Ten subjects, all different, brand new and thrilling, and all yours for only 20c each. You must be delighted or your money back! Rush \$2 (cash, check or money order) to:

SENSATIONAL MOVIE OFFER
Box 46856, Dept P-1
West Hollywood 46, Calif.

BOAT KITS 50 Models 8' to 18'

Free Catalog in Full Color



Runabouts, cruisers, convertibles, fishing, \$41.75 and up, Freight pd. Luger boats equal factory built, yet save you to 2/3 cost. Methods assure a perfect assembly by anyone. FREE color catalog includes. Fiberglass, trailers, paints, hardware, accessories Write now

LUGER INDUSTRIES, INC.
9200 Access Rd.

Dept. A-7
Minneapolis 20, Minn.

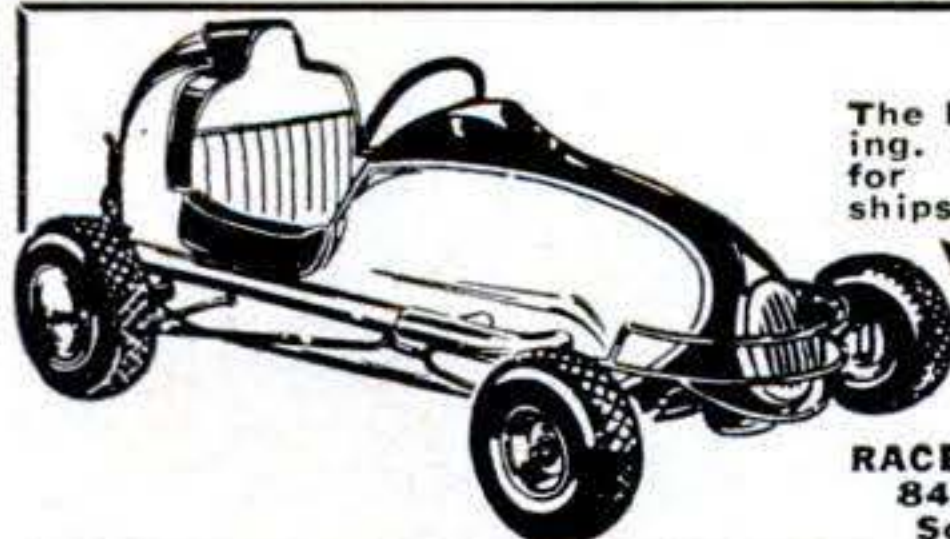

1/4 MIDGETS

The little league of family racing. \$449.00 complete. Write for free literature. Dealerships now available.

RACE-CRAFT

RACE-CRAFT MIDGET CARS
8476 E. Garvey Boulevard
South San Gabriel, Calif.

CREATIVE PRAYER

DEALS DIRECTLY WITH UNIVERSAL MIND!

- ★ Heals the body
- ★ Attracts riches and friends
- ★ Wins love, success, and achievement

Write for free booklet . . . to INSTITUTE OF PRAYER
7321-P Beverly Blvd., Los Angeles 36, California

Every Mason Wants



Masonic books for Blue Lodge Chapter, Commandery, Scottish Rite and Shrine.

Our Rituals Are Used the World Over

Send for free catalog for Masons, Odd Fellows, Knights of Pythias, Knights of Columbus, etc.

EZRA A. COOK PUBLICATIONS, INC.

P. O. Box 796 43D Chicago 90, Ill.

Repair Remodel

Reap the rewards
second phase of the big
HOME IMPROVEMENT COUNCIL CONTEST

“Better Your Home”

Grand Prize \$25,000
\$25,000 in smaller prizes

The contest starts July 1, 1958 and runs to June 30, 1959. Any home owner in the USA, its possessions or Canada is eligible. All entries must be submitted on an official HIC entry blank obtainable from a local building material or hardware dealer displaying the official HIC membership seal.

All you have to do is report on a home improvement project accomplished during the contest period—a brief explanation with a “before and after” picture is all that’s needed.

Any part of the house can be tackled—the attic, basement, bath, face-lifting, garage, grounds, heating and cooling, kitchen, new room, redecorating, storage, utility room, workshop.

POPULAR SCIENCE readers will have a BIG advantage—follow the hints and advice featured in the magazine. Home improvement editorials will help you to do the job easier.

Remember, win or lose—the improvements you make will pay off in extra comfort and convenience for you . . . for years to come.





**no drag
on the rag**

**shine faster with
all-new Carnu**

Shines the deep-down color back better than ever before!

New Johnson's Wax formula wipes off as easy as it wipes on. Actually cleans with less friction—speeds up the shine. All-new Carnu is easier on the finish, easier on you. Cleans as it shines—in one easy go!

“JOHNSON'S WAX” “CARNU” AND “DEEP GLOSS” ARE REGISTERED TRADEMARKS OF S. C. JOHNSON & SON, INC.

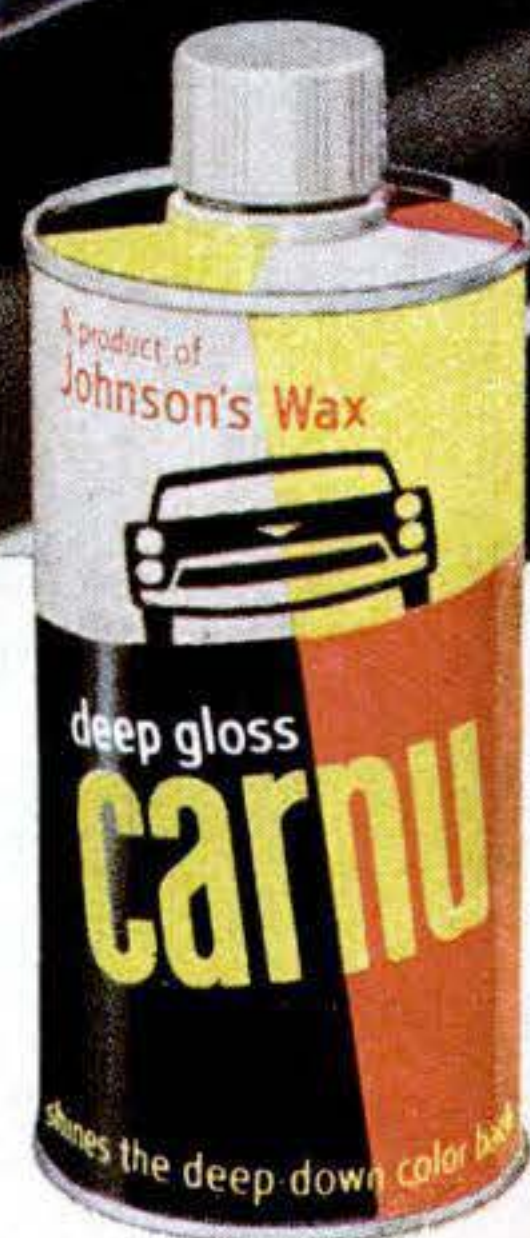

Copyrighted material

Next Big Change in Cars: Flatter Floors

Each year, as cars get lower, that darned hump gets higher. How to get rid of it? Rear engines . . . transaxles . . . front-wheel drive?

By Hubert Lockett

SCREENED behind security precautions that are extreme even for Detroit, engineers are furiously pushing projects that will bring the first basic change in the anatomy of American cars since the industry came of age. Engines and transmissions of the mass-produced cars have always been in front, delivering push to the back wheels by a long shaft. Now, something new is in the wind.

What they are doing. Under the summer sun at proving grounds around Detroit, drivers are sweating out tests on other types of drives designed—guess where—in Europe, and cobbled to American cars. Meanwhile back at the ranch the cost accountants are totting up the discouraging figure on retooling.

These are the choices:

- Front-wheel drive.
- Rear-mounted engines.
- Independent rear-wheel suspension.
- Transmission and differential combined in the rear-axle assembly: transaxles.

Customer unhappiness with split-level floors in the family sedan is sparking this revolution in design. Ever-lower body lines have had powerful sales appeal, but owners are finding that those not-so-sleek obstructions in the floors are unpleasant to live with. The hump down the middle has grown larger with each lowering of the roof height until now the center seat is for children and midgets.

In this battle of the bulge, the engineers have resorted to all kinds of design tactics to let the stylists have their lower silhouette without too great a penalty in floor obstruction:

- Smaller wheels.
- Engines and axles tipped rakishly.
- Two-piece, three-joint propeller shafts.
- Lower hypoid pinions.

They've nearly run out of tricks. About the only thing they haven't

European designs are getting hectic attention as Detroit engineers scurry to catch up

tried is a switch on the old if-you-can't-lick-'em,-join-'em-theme suggested by one engineer—make the tunnels a little higher, use them for armrests and admit that they're building four-passenger cars.

The hypnotic spell cast on American designers by the logic of engine in front with rear-wheel drive is broken now. As long as the passenger compartment could ride atop the drive line, it made a certain amount of sense. But with the floors draped around the drive line now, and stylists eager for still lower roofs, Detroit engineers are scurrying to catch up on their homework.

The hottest possibility—the arrangement that is closest to getting the go-ahead for production—is the transaxle. This unit combines the transmission with the rear axle. With the transmission removed from its position of prominence, attached to the rear of the engine, the hump in the front floor would go. Then the prop shaft would have only the engine torque to deliver to the rear, instead of the torque after multiplication by the transmission, as at present. A smaller prop shaft could be used—beneath a smaller tunnel.

There's another saving on tunnel size, too. In present cars, the body is sprung weight and the drive line is, in large part, unsprung weight. There must be room for the rear of the prop shaft and the differential to move upwards when you hit a bump—without banging the floor pan. Today's tunnels have to afford five to six inches of "jounce" clearance.

Transaxles would probably be combined with independent rear-wheel suspension. Only the wheels would move up and down when you hit a bump. The drive-line components would be fixed to the body so that there would be no relative motion to be accommodated.

The attraction of all this is not just that it would solve a style problem. It would also:

- Distribute weight better. Today's cars tend to be light on the rear wheels unless fully loaded. With the transmission moved to the rear, the balance would be better.

- Lower the center of gravity.

- Improve traction. In addition to more weight on the driving wheels, the prop-shaft torque effect that makes one rear wheel want to spin under extreme conditions would be eliminated.

- Give a better ride. Some engineers say unsprung weight could be cut in half. This would mean not only an improved ride, but also a more easily controlled one—less load and wear on the shocks.

- Improve handling. The difference in handling under power between a left and a right turn (due to the twisting effect of the drive shaft on the unsuspended, rigid rear axle) would be eliminated. The car would hold the road better in fast cornering and braking.

- Make better brakes possible by using inboard brakes. This is not a necessary part of the transaxle package, but while getting rid of unsprung weight you may as well save the weight of the brakes, too. Brake cooling might be better. Brake torque reaction, which currently tends to pretzel the rear springs in a hard stop, would be taken directly by the frame.

Of course you don't win all this without pain. As usual with a new development, you can get more "proof" from the engineers that the idea is impractical or undesirable than information about how it can be done and its advantages. Allowing for the usual pessimism, disadvantages boil down to these:

- It's expensive.
- Transmission controls would have to be extended back to the rear end.

- Station-wagon bodies would pose a problem: They need an uninterrupted floor at the rear.

- It would rob space from the trunk compartment. There would have to be a bulge in the floor of the trunk to make room for the transmission and still maintain ground clearance.

- It's expensive.
- Weight goes up. Although the unsprung weight would be reduced, designers estimate an increase in total weight of 25 to 50 pounds.

- It doesn't completely dispose of the floor obstructions—it only reduces them.

- It's expensive.

If, as some engineers contend, trans-

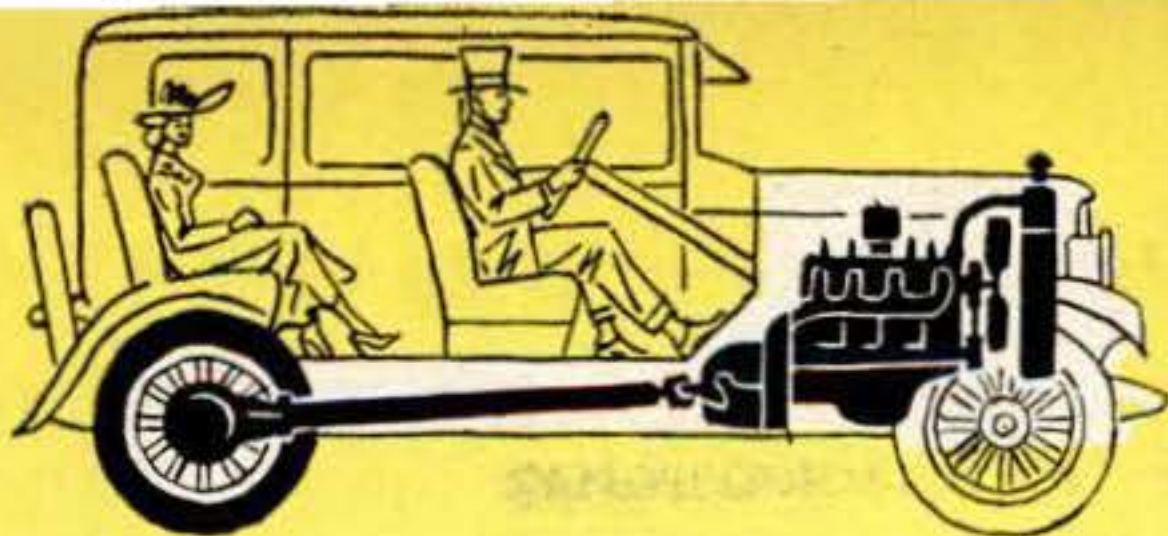

PASSENGERS PERCHED atop the running gear back when floorboards were actually boards—floors were flat.

FLOOR HUMP CAME with the first lowering of car heights. Hypoid pinion and two-joint prop shaft helped keep it small and scarcely noticeable.

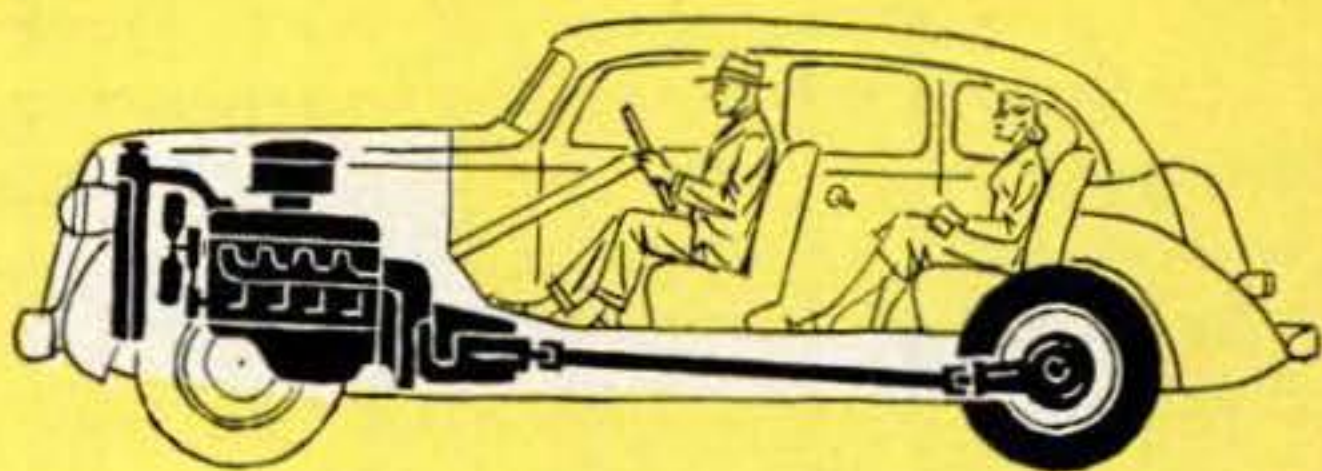

How the Auto Got Its Hump—and What Can Be Done About It

LOWER HYPOIDS and three-joint prop shafts have been resorted to in the latest low-slung beauties, but even so, today's passenger compartment is draped around the drive line, leaving a swollen hump down the middle.

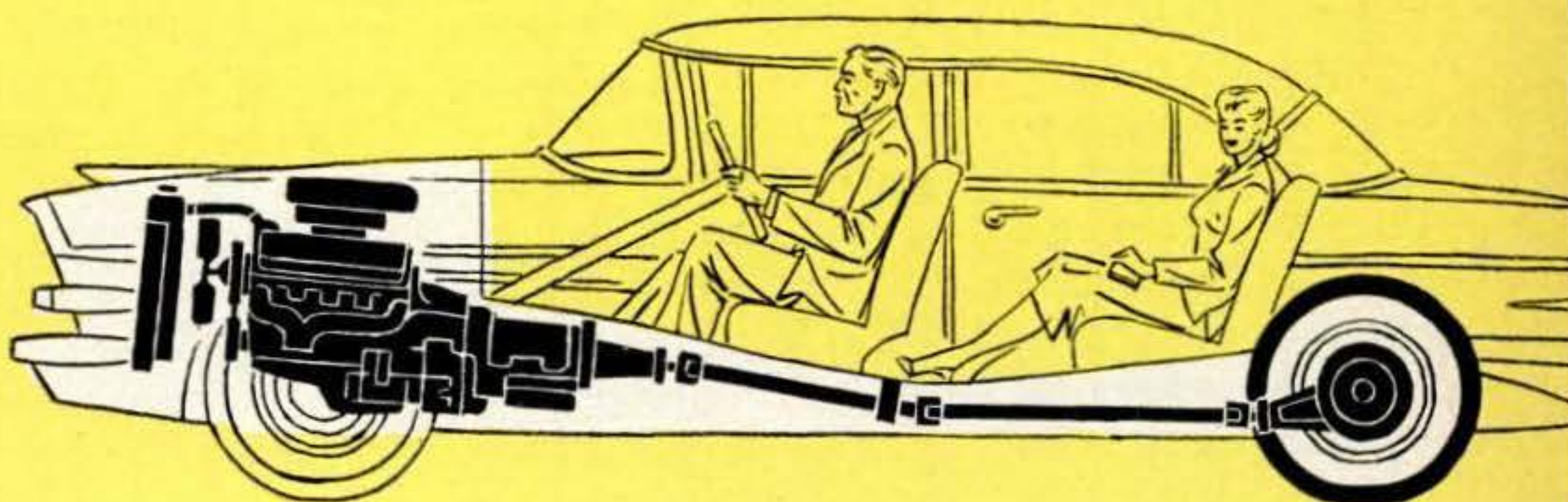

FRONT-WHEEL DRIVE licks the problem of the hump by avoiding the cause. With no drive line underneath for which clearances must be provided, floors can be flat, even with lower silhouettes.

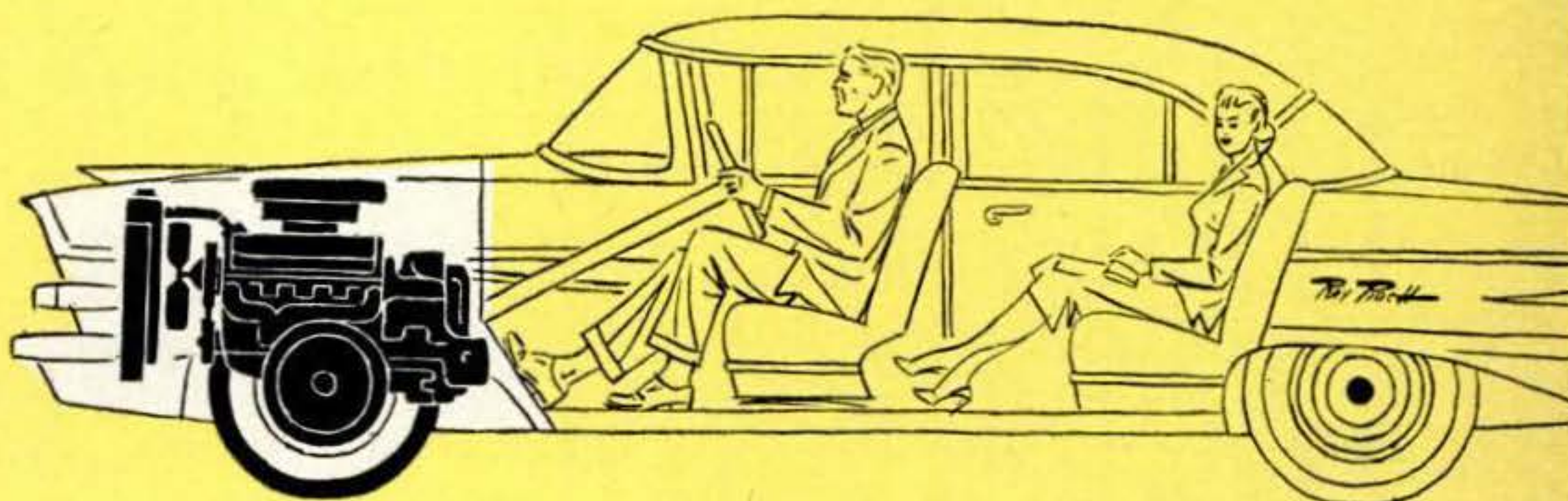

TRANSAXLES are the latest (and most likely) proposal. With the transmission moved to the rear axle, the tunnel could be reduced and that hump would go. Floors would be almost unobstructed.

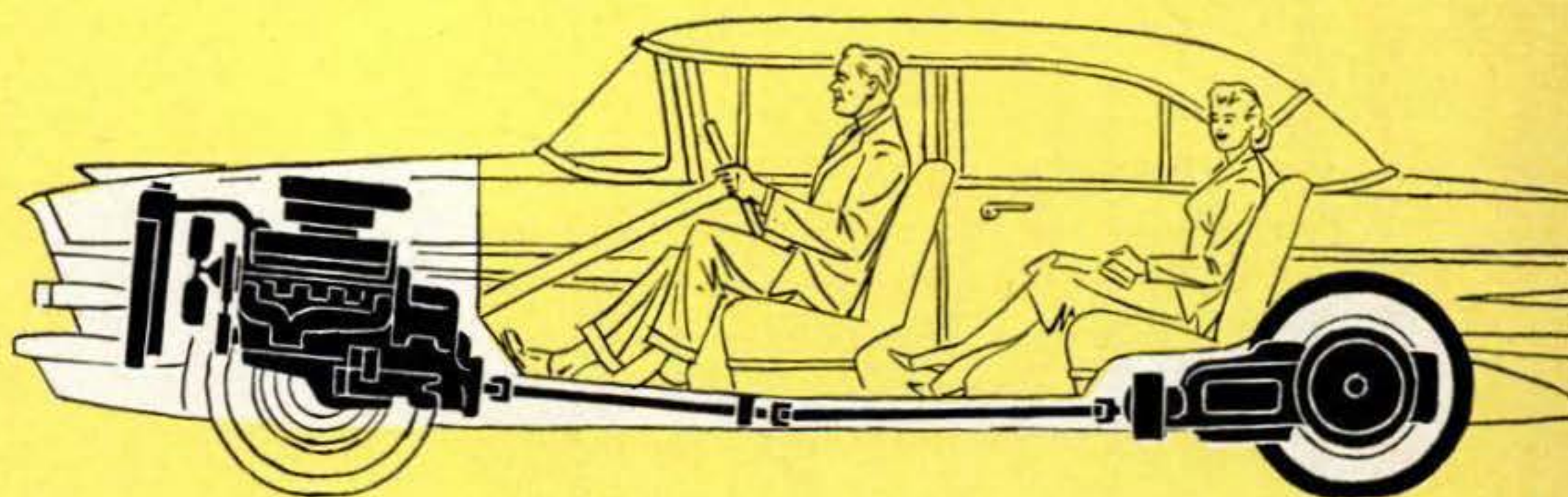

REAR ENGINES offer the same clear floor as front-wheel drive, but weight distribution is a serious problem. Lighter engines would be a must to make this scheme feasible.

The floor hump must go . . . Most likely solution: the

axles are not the best answer, what about the other possibilities?

Independent rear-wheel suspension is all you need—so one argument goes. Leave the transmission where it is. You would still get many of the ride and handling advantages. Retooling costs would be less and there would be no problem with station-wagon bodies.

The trouble is that this would do little or nothing about the problem that started all the fuss: the transmission hump in the front floor. And it would gain only a modest reduction in the tunnel.

Nevertheless, this possibility is getting serious consideration in some quarters. Chrysler has been experimenting with a trick that may hold part of the answer. They've tried moving the transmission just far enough to the rear so that the hump is tucked under the front seat.

The obvious answer to the problems created by having to provide clearance for the drive line under the passenger compartment is—not to have a drive line there in the first place. Of course this means either a front-drive or a rear-engine car. Both these schemes have been thrown up to Detroit engineers so many times during the years when their dogmas dominated all designs that the mere mention of either triggers a fusillade of ready-made objections. You'd think no such vehicle had ever run. But there are at least a dozen front-drive cars and half a dozen rear-engine cars made in Europe. They work—and please the customers.

Recently Peter Kyropoulos of General Motors told the SAE: "The pros and cons of front-wheel drive, as well as the rear engine, have been discussed with more emotion than common sense. Neither arrangement poses insurmountable problems . . ."

Front-wheel drive gives maximum uninterrupted floor space. It is particularly well suited to station-wagon bodies. The complete power package including front wheels, steering gear and suspension could be built as a unit instead of hanging the various components on the frame piecemeal as now. With all the machinery bunched up front near the driver, engine and transmission controls would be short, direct, and well protected.

However, the concentration of the

heaviest parts in front is a drawback. It is generally conceded that the ideal weight distribution is 50-50—equally divided between front and rear wheels. Practically, this is rarely achieved in a family car. When there is variation from the ideal it is better to have the front end slightly heavier for best stability. But, with the big engines shoved well forward in the present Detroit cars, they are already too nose-heavy for good handling with only one or two passengers aboard.

Steering the driven wheels is also a problem—especially when they are geared to the bigger engines customary in American cars. When you transmit torque through a U joint, a force is created that makes the input and output shafts want to line up in a straight line. The more torque you apply, the stronger this force is. You have experienced this effect if you have ever used a U joint on a socket wrench. The harder you twist, the more effort you have to exert to keep the handle from straightening out.

Durability of the U joints is another snag. They were the Achilles heel of the ill-fated Cord, the only American-made front-wheel-drive car to achieve a measure of success.

Still, according to most of the engineers consulted, there is no fundamental engineering reason why these problems can't be solved satisfactorily. They see the biggest objection in the need for mastering new driving techniques.

While the roadability of a front-drive car is, in many respects, superior to that of a rear-drive one, there is a difference in the handling. In many driving situations, those all-important quick reactions needed to stay out of trouble are just the reverse of the ones called for when the rear wheels are driven.

For example: Suppose you find yourself—in your rear-drive car—in a turn going a little too fast. You are on the verge of a skid. Your corrective steering is into the skid or opposite to the way you were going. But if the driven wheels are in front, the correction is a harder turn in the direction you were headed.

In practice, however, such objections may very well fall by the wayside just as did similar objections to power steering when it was still untried.

transaxle—transmission combined with the rear axle

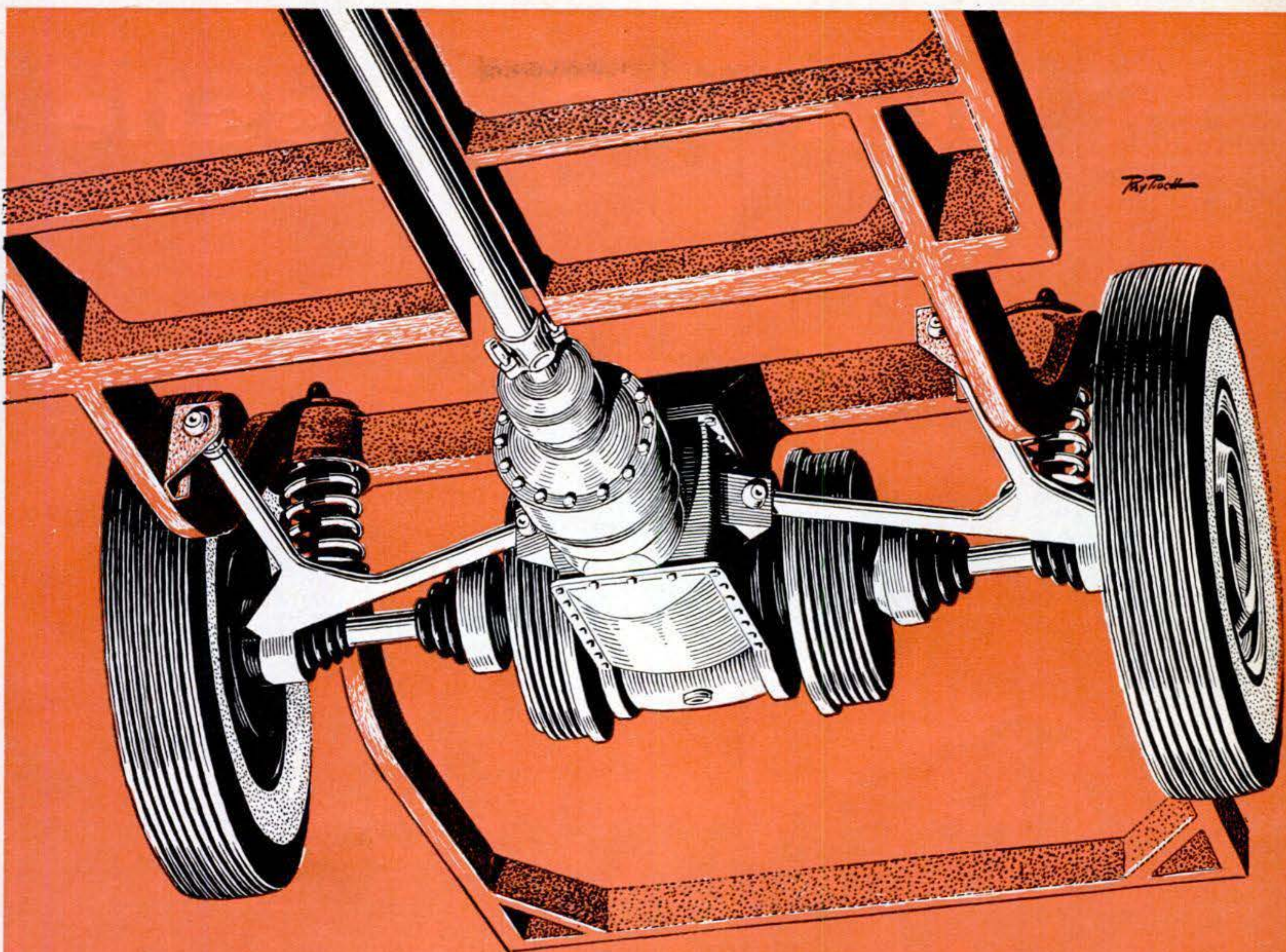

TRANSAXLES would permit a badly needed transfer of weight to the rear wheels. Unsprung

weight could be reduced by using inboard brakes and individual rear-wheel suspension.

Rear-mounted engines will also banish the drive line under the floor without incurring the problem of steering the driven wheels. So far as this factor is concerned, the handling would hold no surprises for the American driver. This makes it an inviting prospect.

The big obstacle is the overweight engines now used. The best weight distribution you could hope for with present engines is about 40/60. Such a tail-heavy car would be even less stable than one heavy in the front.

When you add three more problems—the extension of the engine and transmission controls forward, unsuitability for station wagons, lack of luggage space—the rear-engine car seems the least likely

arrangement to get the engineers' nod.

Almost all evidence coming out of Detroit indicates that the decision has been made—the hump has to go. The only question is how soon and by what route. Reliable reports say GM has developed the transaxle to the point where they are conferring with machine-tool makers for the machines to produce them. Ford is apparently giving front-wheel drive much more than a casual study—possibly for use on a smaller car.

Best estimate for the earliest models that will show any of these innovations: 1961. If business continues to lag, however, a crash program might get the transaxle into a 1960 model, to give sales a much needed needle.

END

PS Exclusive

New U.S. Missile



POTENT PARASITE: Hooked to the flank of its B-47 host, Rascal awaits signal to go into business on its own.

Mating missile to bomber, crewmen hang it under right wing. Now nitric acid is pumped in.



Is Launched from Bomber

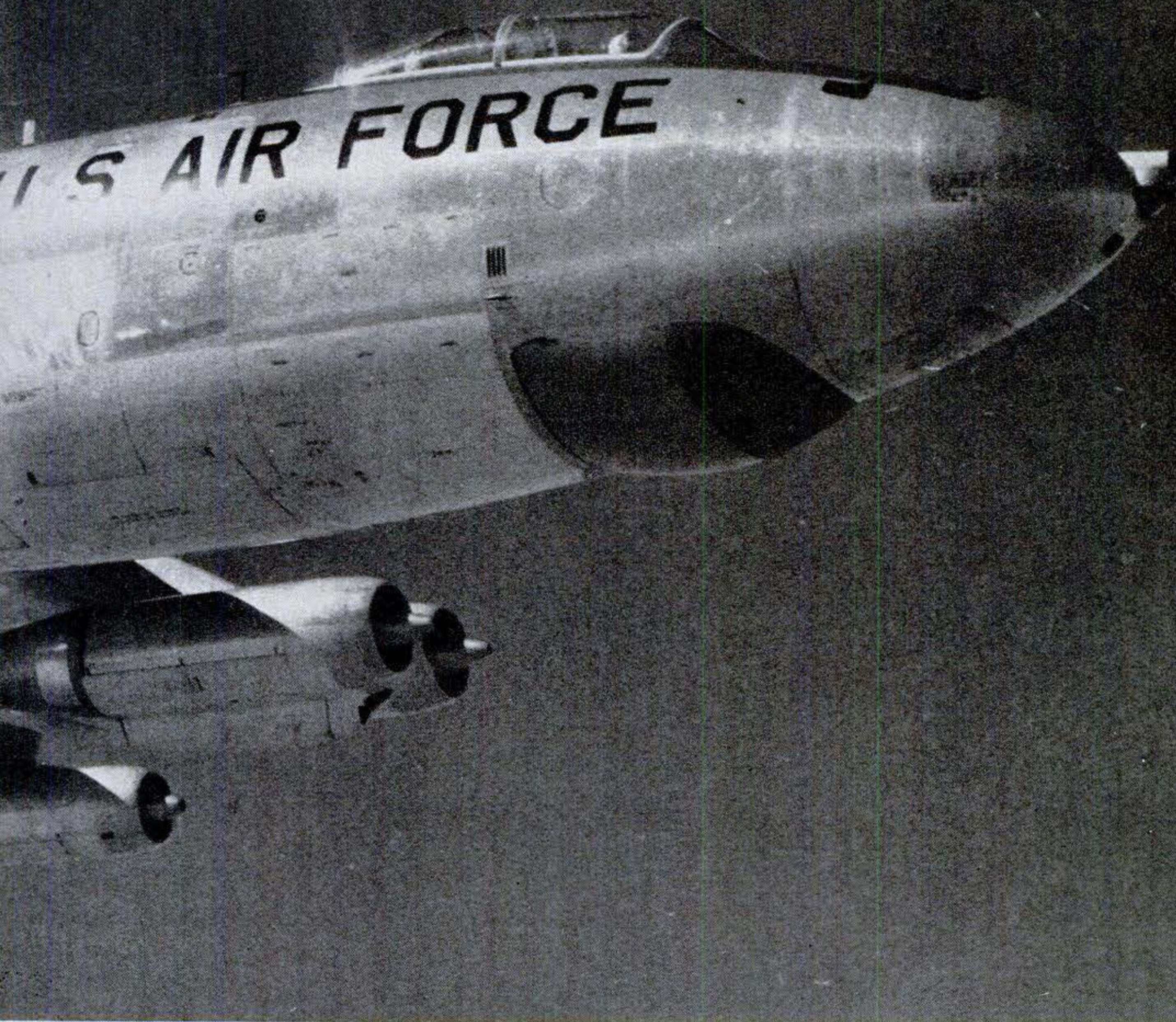

By Frank Harvey

A STRATOJET bomber piloted by Maj. Arthur Roberts and Lt. Hal Howes left Eglin Proving Ground in Florida, flew by a secret route to the New Mexico desert and dropped a huge pink object with fins on nose and tail. The pink object fell free. The airplane turned violently homeward.

Bright fire squirted from the tail of the

pink shape and it began a smooth high-speed climb toward the deep purple of outer space. The fleeing bomber was not yet through with its pink bird. Maj. Ellison Thornton, the navigator-bombardier, crouched in his cubbyhole controlling the missile's flight path.

Seconds passed and grew into minutes as the jet bomber sped away from its departing weapon. Then Thornton, who'd been guiding the flying bomb from the in-

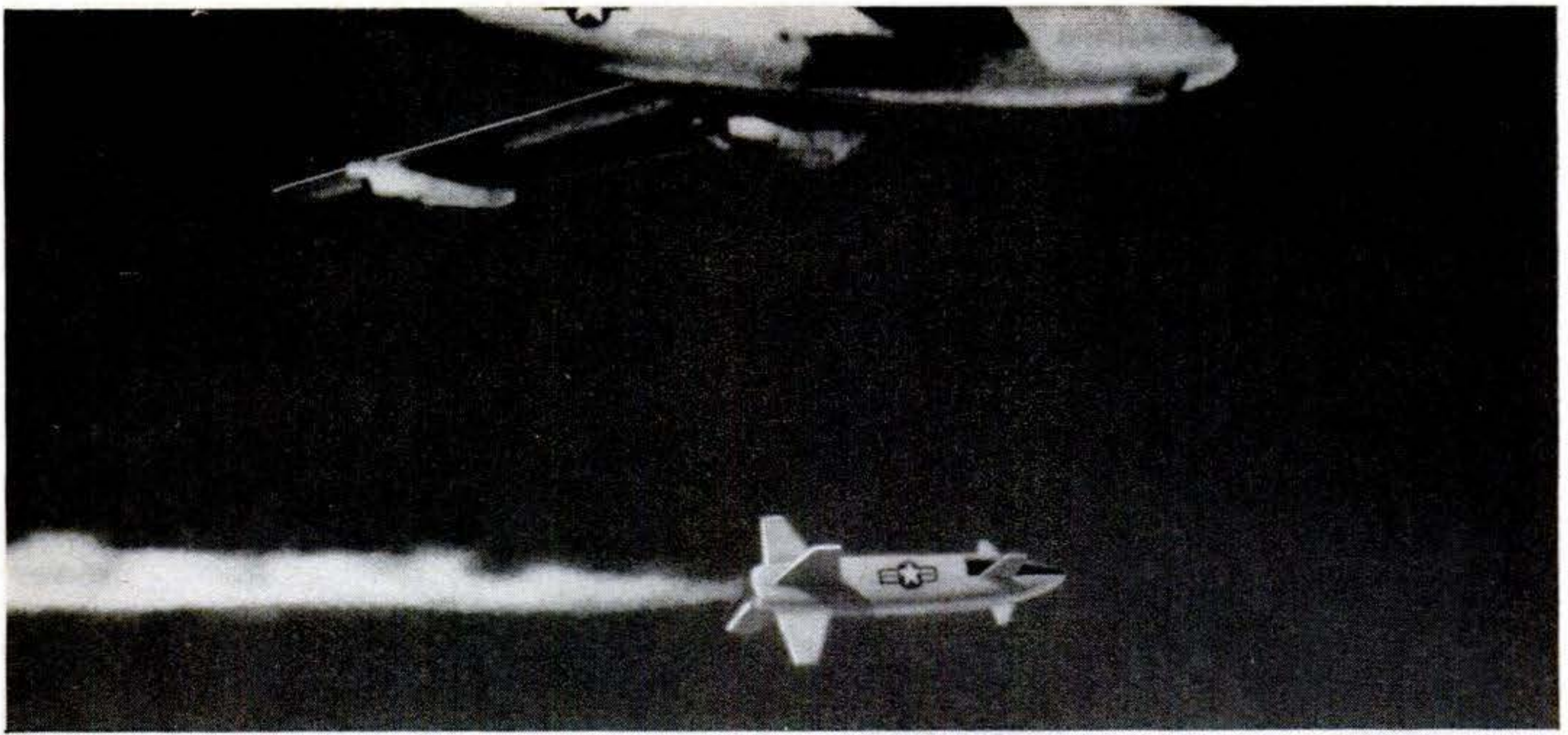

Launched but still under orders, the "Crew Saver" falls away, freeing plane to head home.

stant he'd released it, pressed his "dump button" and the missile jackknifed and screamed down on a target more than 75 miles away.

"Run complete," Thornton announced on the intercom. "Looked good."

The bomber snored onward at high altitude. Presently, in the blue distance ahead, a KC-135 jet tanker appeared. Roberts eased in behind, hooked up, and filled his tanks. In due course the two planes landed back at Eglin and learned they'd made an excellent hit on the target—good enough to have wiped out an enemy city if their weapon, the Bell guided missile known as the Rascal, had been armed with its hydrogen warhead.

The Rascal's bull's-eye was reported in detail on the front page of the *Eglin Eagle* when POPULAR SCIENCE photographer Bill Morris and I arrived to cover the story. It might have been easy to jump to the conclusion that the Rascal is the answer to a bomber crew's prayer: You fire while still out in the boondocks, whip around and hike for home at near sonic speed, relatively safe from the enemy fighters and missiles to be expected near a key target. This, of course, is the philosophy behind the Rascal.

The Rascal is one of a large and fast-growing family of guided air missiles: the Green Quail, Hound Dog, Goose and Genie, to name a few. These birds have a bewildering and deadly capability. Some act as decoys, confusing enemy radar and interceptors. Other birds detach from a bomber and take off after fighters like

striped-tailed ducks. Still others, like the Rascal, zoom ahead at supersonic speed carrying an awesome nuclear punch to heavily defended targets.

The hard facts on Rascal are simple: range, over 75 miles; speed, supersonic; warhead, nuclear; length, 32 feet; diameter, four feet; accuracy, 1,500 feet; power plant, rocket engine; flight control, guidance from mother plane.

Growing pains have been serious. The Rascal didn't get perfected overnight. More than 50 propellants were tested before Bell settled on JP-4 jet fuel and fuming nitric acid. JP-4 is ideal because it's available in quantity at most Air Force bases. Fuming nitric, on the other hand, isn't ideal by a long shot—but it's better than some other fiendish liquids that tend to explode unexpectedly.

Bell safety-engineered the fuming nitric acid with great care. Not a drop is supposed to reach open air during a fueling. The crew rolls its big nitric truck up to the bird, which is already fueled with JP-4 and attached to the flank of a bomber. The armored nitric hose is then attached and checked for leaks before the ticklish transfer is begun.

To make things doubly safe, fuel handlers are covered from head to foot with protective gear. But minor slips do happen. Airman First Class Conally Stansell of Morrow, Ga., showed a festering yellow-and-green acid burn on his forearm. He got it when acid spilled during flushing out of a missile that had returned from a flight without being fired.

"We never worry about the fueling," Stansell said. "It's getting the miserable stuff out again after an abort that's dangerous. Takes us an hour to put it in—and about 10 hours to get it out again."

Had he noticed the burn at once?

"Would a person notice a white-hot coal if somebody stuffed one up his sleeve?"

Stansell's buddy, Airman First Class Jake Snyder of Bristol, Tenn., related a frightening experience. During the flushing of a missile he'd got a dash of acid in the face (having lifted his mask to get a breath of fresh air). "I had sense enough to keep my eyes tight shut," Snyder says, "and the boys ran me over to the eyeball washer and stuck my face in it. No sweat. They worked so fast I didn't even end up with a scar."

Putting the bird aboard. One thing an observer wonders about is the really immense detail necessary to get the Rascal into the air. The big birds are brought to Eglin Proving Ground snuggled up in the belly of a converted B-50 bomber. The bomber is towed backwards over a concrete pit. A special missile carriage (known as the "miscarriage" to cynical offloaders) accepts the missile and trundles it into a large building where technicians await it.

Clustering around it like flies, they undress it as much as possible and peek into every cranny, looking for maladjustments. Then they button it up again and put it through a propulsion check, using a machine that simulates every phase of firing the rocket power plant. Next the bird is rolled over to a large yellow machine that gives it the electronic once-over—simulating all guidance functions.

Loading is relatively easy. The JP-4 jet fuel is put in while the bird is still in the missile area. The dummy warhead is attached, and the bird taken out to the aircraft and fastened to the right side on a

special bracket. An impressive array of fire trucks, an ambulance, and a small army of rescue men wearing safety suits and oxygen-breathing equipment accompany the missile to its "mating."

The nitric acid (which supplies the oxygen necessary to burn the JP-4) is pumped in. Then the final and most dangerous step—pressurization with high-pressure nitrogen—takes place. A truck hooks up to the fully fueled missile and bleeds nitrogen into various internal pressure vessels that will expel the propellants into the motor at the proper time. An overfill here could result in a rupture that would inadvertently mix the nitric and the JP-4 and might cause a boom that could be heard all up and down the Florida panhandle.

"We've never had an accident," says Lt. Bob Weir, the assistant missile maintenance officer. "I doubt if we'll ever have one; we really respect the materials we work with. Know what I mean?"

I knew in a general way, but Weir then explained that white fuming nitric acid and hydrazine (the spark plug of the engine) unite in what's called a "hypergolic" reaction.

"What's that?" I asked.

"They explode," Weir said, grinning.

A cylinder about two inches in diameter and eight inches long, containing hydrazine (and known as a slug), is placed in the lines leading to the rocket engines. At the time of firing in the air, a tiny diaphragm breaks and lets the nitric acid hit the hydrazine. The hypergolic reaction takes place. The JP-4 squirts in from another line under nitrogen pressure, and the explosion becomes a steady rocket fire. The Rascal is now in business on the power phase of its climb.

Flying a B-47 with a missile hooked to its flank is not difficult after a pilot gets accustomed to it. But if anything hap-

Leading parade of its attendant vehicles, Rascal maneuvers into place for loading on B-47.





ACCIDENT INSURANCE THAT PAYS OFF FAST: Emergency showers are on tap close to crew that handles hazardous fuel for the Rascal missile.

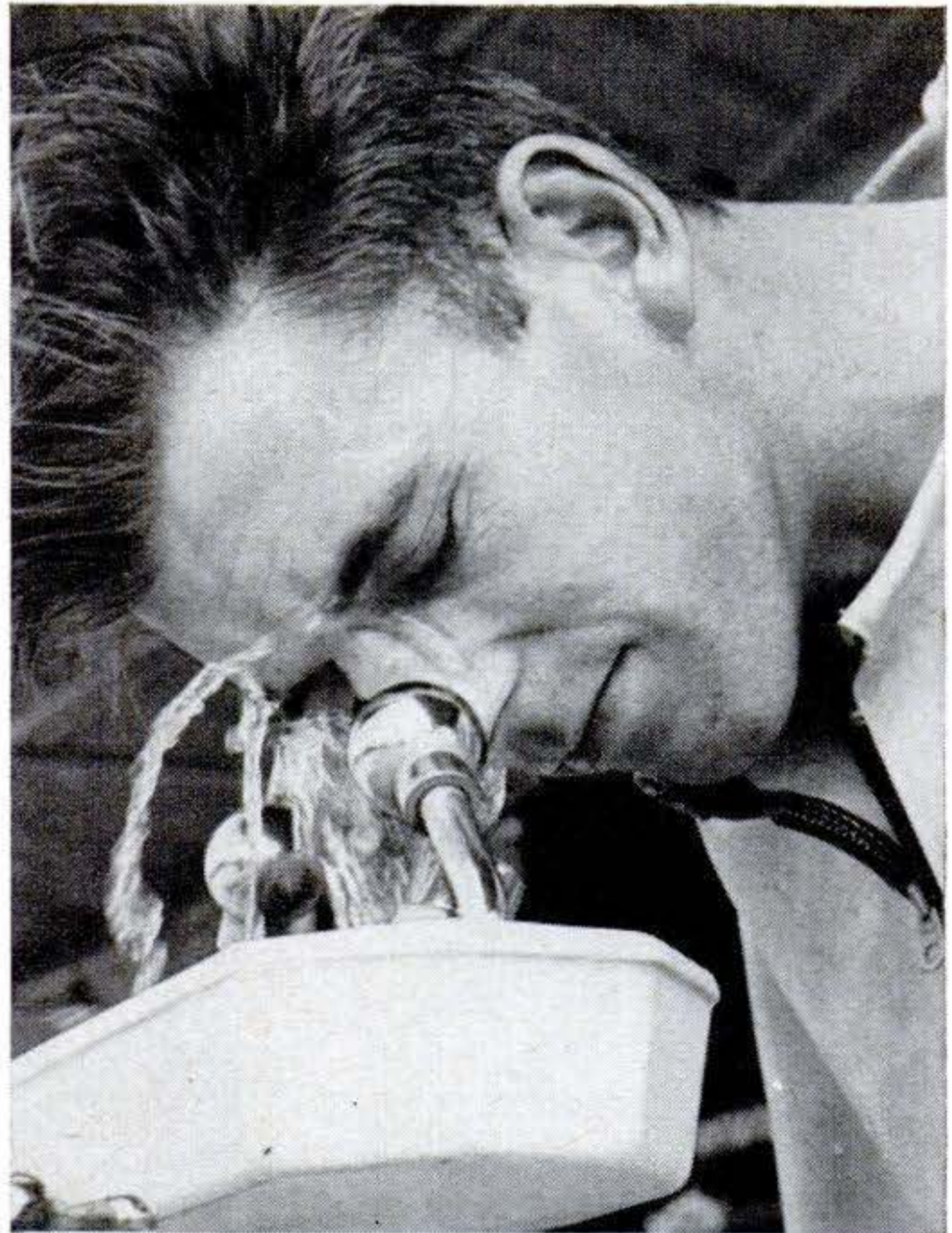

EYEBALLS AWASH, Airman Snyder averts crisis after careless splash of acid. Persnickety safety precautions cut risks to a minimum.

pened during the takeoff roll, serious trouble could result. The nitric acid probably would eat up a mile or so of concrete (only a drop or two under the nozzle of the aluminum-lined acid tank car had eroded a hole in the concrete there).

They've nicknamed the Rascal "The Crew Saver" because it eliminates the need for boring in through missiles and screeching enemy jets. Pilots and bombardiers are naturally enthusiastic. Of course 75 miles, at today's jet speeds, isn't very far out of town. But it's better than 10 miles, which is what the B-47 would have to do if it were undertaking a normal gravity drop.

The important thing to remember is the fact that the Rascal is a research weapon of great value. The lessons learned slowly and painfully with the Rascal can be quickly and easily applied to the newer air-to-ground missiles that are on the way.

One of these, the GAM 77 Hound Dog, will be carried by the Boeing B-52 intercontinental giant. Details on this bird are secret now, but we know for sure that it will have much greater range and carry an even bigger punch than the trail-blazing Rascal. **END**



A British engraving pictured such news highlights as winged men and hut-building beavers.

The Day They Discovered Men on the Moon

**The great newspaper hoax of 1835 fooled millions. Could we—
in 1958—be taken in by such a fable brought up to date?**

By George R. Price

IMAGINE that tomorrow morning some highly respected American newspaper—such as the *New York Times*—published an exclusive, front-page interview with a Russian scientist, a Dr. I. Marchenko, who has managed to escape to the United States.

He is being held incommunicado at an Army camp in Alabama—because the Department of Defense is afraid panic will

sweep the country if his story gets out—but somehow a reporter has managed to find and interview him. And there's a statement by "The Editors" that they know the story to be true—even though the Government will deny everything.

The *Times* interview—we're still imagining, remember—is to be published in three installments, and in the first installment Dr. Marchenko reveals that three times—in December, 1957, and February and March, 1958—Russia faked un-

With the fourth installment, the little upstart Sun



ITALIAN ARTISTRY created this picture of a winged moon man to run with the story. Note the addition of a smoking lunar Vesuvius.

successful ICBM tests to confuse the U.S. radar in Turkey, while shooting manned rockets to land on the far side of the moon. The first rocket crashed, but the second and third were successful. Dr. Marchenko was in the second rocket, and he describes its takeoff and the flight through space.

Later, our imaginary Dr. Marchenko tells about the landing on the moon—where they name their camp Khrushchevgrad—and about how they start exploring the surrounding territory. Soon they discover a region where carbon dioxide and carbon monoxide gases well up from fissures in the ground, and within the fissures strange lichens grow to six or eight feet.

THEN the third rocket arrives, and they press their explorations farther. They climb down inside some of the fissures, and find many different animals that live off the plants, breathing the carbon monoxide. There are little blue animals somewhat like chipmunks, and slow-moving, leprous white animals the size of St. Bernard dogs. And finally, a half-mile down inside the largest fissure, they discover chambers excavated in the rock, their walls lined with a luminescent ceram-

ic, and their furnishings indicating a high level of intelligence. But they can find no trace of the inhabitants.

In the final installment, Dr. Marchenko tells how he returned to earth, escaped through East Germany into West Berlin, and was flown to the United States in an Air Force plane. And the newspaper announces that its circulation has now passed the 5½ million of *Pravda*, and is the largest in the world.

If this were to happen, would you believe the story?

It's easy to say no, but actually—not quite 125 years ago—millions of people in America and Europe believed a much more extraordinary story about the moon. This was the famous “Moon Hoax,” probably the most successful newspaper hoax in history. Let's take a look at what happened then to see why it was so successful.

IN THE fall of 1833 the famous astronomer Sir John Herschel left England bound for the Cape of Good Hope with a shipload of optical instruments, to set up an observatory and map the stars of the Southern Hemisphere. The first report the United States received about his findings came in the *New York Sun* on Friday, August 21, 1835:

CELESTIAL DISCOVERY

“The Edinburgh [Scotland] Courant says—‘We have just learnt from an eminent publisher in this city that Sir John Herschel, at the Cape of Good Hope, has made some astronomical discoveries of the most wonderful description, by means of an immense telescope of an entirely new principle.’”

Then, four days later, this headline appeared on the front page of the *Sun*:

GREAT ASTRONOMICAL DISCOVERIES.

LATELY MADE

BY SIR JOHN HERSCHEL, LL.D., F.R.S., &C.

At the Cape of Good Hope

[From Supplement to the *Edinburgh Journal of Science*.]

The *Sun* explained that “a medical

announced it had the world's largest circulation

gentleman" from Scotland visiting New York had with him a copy of the "Supplement." He had seen the item about Herschel, and had given his copy to the *Sun*, which was going to reprint this historic scientific article—written by Dr. Andrew Grant, Herschel's principal co-worker at the Cape of Good Hope and a well-known scientist in his own right.

The first installment was largely devoted to the extraordinary new telescope, with its colossal 24-foot, 14,826-pound lens that gave 42,000-fold magnification, followed by a microscope that magnified thousands of times more. To eliminate the difficulty that the more an image is magnified the fainter it gets, Herschel focused the first image from the telescope on a polished glass plate, and illuminated it by the intense light from a piece of lime heated by a hydrogen-oxygen flame. Then this brightened image was further magnified by the microscope, and projected onto the wall of the observation room (as on a motion-picture screen).

IN THE second installment, the wonders began, as Sir John and his assistants took their first look at the moon through the new telescope on the evening of January 10, 1835. First they saw an area covered with greenish-brown basaltic rock, and then suddenly they came upon dark-red flowers like rose poppies—the first signs of life on the moon!

A little later they found forests of trees looking like English yews and firs. Next—they explored the area known as the Mare Nubium (the "Sea of Clouds") of Riccoli: ". . . fairer shores never angel coasted on

a tour of pleasure. A beach of white sand, girt with wild castellated rocks, apparently of green marble . . . feathered and festooned at the summits with the clustering foliage of unknown trees, moved along the bright wall of our apartment until we were speechless with admiration."

Then came a region of great amethyst crystals 90 feet high. And finally they discovered the first animal life: herds of "brown quadrupeds" like bison; unicorns



MOONSCAPE STAGE SET from a New York "Panorama of Lunar Discoveries" appeared as an engraving in the *Sun* on October 16, 1835.

of a "bluish lead color, about the size of a goat;" water birds and "a strange amphibious creature of a spherical form, which rolled with great velocity across the pebbly beach . . ."

In the third installment, the zoological list grew. Even more fabulous animals were added: "a small kind of reindeer, the elk, the moose, the horned bear," an "elegant striped quadruped about three feet high, like a miniature zebra," and—most astonishing of all—the "biped beaver," which had no tail, walked erect on its hind legs, and built huts with tall

chimneys, out of which smoke emerged.

BY THIS time New York was wild with excitement, and little else was talked about except the amazing moon discoveries. And when the fourth installment was published, on August 28, the little, upstart New York *Sun*, not yet two years old, announced that it had the world's largest circulation—19,360, against 17,000 for the great London *Times*, founded 50 years earlier.

The sensational event in the fourth installment was the sighting of the first lunar men, which the account named the "Vespertilio-homo," or "man-bat": "They averaged four feet in height, were covered, except on the face, with short and glossy copper-colored hair, and had wings composed of a thin membrane, without hair, lying snugly upon their backs, from the top of their shoulders to the calves of their legs."

There were still two more installments, and the wonders continued. A solid quartz crystal 340 miles long, hills of "snow-white marble," a "tall white stag with lofty spreading antlers black as ebony," great temples of polished sapphire, with roofs of yellow metal supported by sapphire columns 70 feet high, and "lovely green valleys . . . of paradisiacal beauty and fertility, and like primitive Eden in the bliss of their inhabitants." And at the very end of the last installment the astronomers reported a highly superior race of the man-bats, "of infinitely greater personal beauty . . . scarcely less lovely than the general representations of angels by the more imaginative schools of painters."

Such was the amazing story that began to spread, first through America, and then around the world. And everywhere it went, it was reprinted in newspaper or pamphlet form, with translations into French, German, Italian and many other languages.

But how many people actually believed it? According to one contemporary writer, in America "not one person in 10 discredited it." True, some New York newspapers promptly charged that the whole thing was a hoax. But people knew that papers were such bitter competitors that occasionally rival editors would assault each other on the street. So of course the other papers were jealous of the *Sun* for its scoop, and called it a hoax. And so

even when the New York *Herald* stated that the Edinburgh *Journal of Science* had gone out of existence a few years earlier, and identified the author of the moon story—correctly, it later proved—as Richard Adams Locke, the *Sun's* star reporter and a brilliant graduate of Cambridge University, still many people continued to believe in the moon discoveries.

WHY was this extraordinary hoax so successful? At least five different reasons can be assigned:

- People everywhere and at all times like to hear about and believe in the miraculous and unusual.

- The story was ingeniously presented, starting with the brief announcement, and then gradually building up through the telescope, the red flowers, and the conventional animal types, before introducing very strange animals and "man-bats."

- The technical details about the telescope impressed people, so that they assumed that if something seemed improbable, it was just because they did not understand it.

- The article named real men like Herschel, real areas on the moon, and specific dates, and this sprinkling of reality and specific details made the fantastic part seem true.

- Finally, the hoax was aided by some unexpected happenings. For example, one day a distinguished-looking elderly gentleman told the crowd gathered outside the Sun Building that he had himself seen the gigantic lens being loaded on shipboard at the East India Docks in London. (Locke, in the crowd, was flabbergasted.)

Of course if people had known more about science in those days, they could have quickly detected the fraud. The most obvious error was in claiming that the moon had seas and an atmosphere dense enough to support winged flight. Also, the gigantic telescope was completely absurd. To shine a bright light through a faint image would simply wash out the image instead of making it brighter. Finally, the whole story about life on the moon was just a little too pat, with its picture of unicorns, Gardens of Eden, and beings who looked like angels.

What does this mean for us today? Now, just as much as ever, people are eager to believe in the strangest and most

[Continued on page 218]

First Iron Curtain Car on Sale in U.S. Czech-Built Skoda Uses Aluminum Engine

**Engineering features you'd expect only on a costlier car
give this little sedan a solid feel and perky personality**

CAR-CONSCIOUS Americans are getting their first close look this summer at an automobile built on the far side of the Iron Curtain and shown in this country, not as a curio, but as a consumer product actually available in the U. S.

What they're seeing—leaving politics out of this—is quite a piece of hardware for its \$1,595 price tag.

You'll find a comfortable familiarity about the Skoda's looks: The rounded, blunt nose and notch back are scaled-down Detroit, circa 1950. According to the importer, Continental Car Combine, about a thousand of these cars have been quietly sold in this country in the last year to test their acceptability to Americans. Current plans are to import the car in quantity.

Your reactions to the Skoda depend almost entirely on the prejudices you bring along on your first ride. The ride is very firm; in fact—let's face it—it's downright rough on posteriors pampered by pillowy American-made cars. But, if driving is fun as well as transportation for you, you will quickly forget about the bumps, in your delight with the way the car handles. Your first 10 minutes behind the wheel make you want to hunt up winding country roads just for the fun of taking the turns.

Steering is quick, precise, and very light. Even in parking, the 16-inch steering wheel can be cramped with surprising ease the 1½ turns required for full left or full right. Over 30 m.p.h. there is slight oversteer that is uneasy-making until you get used to it.

Shifting among the top three gears



Skoda-440 two-door sedan has conservative lines but still looks at home on American highways.

can be indulged in with abandon. Synchronization is excellent. Minor frets: rude, truck-like noises in low gear, excessive gear hum in third, and an exasperating willingness of the column-mounted shift lever to drop into the reverse slot if you absentmindedly revert to three-speed shift pattern.

Performance is sprightly. This was so even on the test car—a two-door sedan, series 440, not yet broken in, with only 300 miles on it. The car seemed a trifle more able at low r.p.m.'s—more forgiving of negligence in downshifting—than the VW, although top speed is about the same, 68-70 m.p.h. The four-cylinder, OHV, liquid-cooled 40-horse engine started readily after a nippy, drippy night at the curb, but was reluctant to assume its chores until after a three-to-four-minute warm-up. A canvas-curtain air shutter behind the radiator assists in warm-up and for driving in very cold weather.

Old-timers will get a twinge of nostalgia from the businesslike hand crank supplied and the hand-operated lever on the fuel pump for priming the engine. A "zero starting device" turns out to be the manual choke.

A three-day check on mileage for typical commuter driving showed miserly fuel consumption—28.6 m.p.g. On the

open-road the car should live up to its maker's claim of about 35 m.p.g.

At the curb, the Skoda looks bigger than a Volkswagen although the wheelbase and overall length are identical. This impression of size is not all illusion. The trunk has 12 cubic feet of luggage space compared with a little over five for the VW, and the back seat a couple more inches of headroom. Curb weight is 2,050 pounds as against VW's 1,802. Visibility is excellent and contributes to the feeling of inside roominess.

Interior trim is a bit on the dowdy side. Cushioning in the seats and backs is meager. The rubber floor mats in front have a tendency to bunch up under your feet and they don't cover the rather bulky transmission hump. Kindest comment on the outside paint job: mediocre.

On the plus side: beautifully finished aluminum hardware, courtesy light in the roof that lights when either door is opened, three ash trays, and a couple of ingenious coat hangers in back. The divided backs of the front seat are individually adjustable for seating posture. Workmanship in fitting the windows and body panels is good.

Engine block, head, pan, and transmission housing are all made of aluminum alloy. The chassis is built around a single tubular backbone that forks toward the front to form a cradle for the engine. Road clearance is 8½ inches—one of the highest in the current crop of passenger cars, foreign or domestic. Transverse springs with independent suspension are used on all wheels.

In addition to the 440, two other models will be imported: the 445, same as the 440 with the engine souped up five more horsepower; and the 450, a cloth-top, four-passenger sports car with a 50-horsepower engine.

The importer says he has stipulated some 35 minor modifications that will appear on all future deliveries—including slightly softer springing, better paint job, and improved interior finish.

Factory production on the Skoda is reported to be 200 units a day with output steadily increasing. At the price—and if the factory does a reasonably good job in delivering the requested changes—and if its country of origin doesn't handicap acceptance here—the car could offer stiff competition to the VW.—*Hubert Lockett.*

.....	
Price (New York port of entry including federal tax).....	\$1,595
Wheelbase	94.5 in.
Length	160 in.
Tread.....front, 47.6 in.; rear, 49.2 in.	
Width	63 in.
Height	56.3 in.
Ground clearance	8.5 in.
Weight	2,050 lb.
Performance	
Top speed	68 m.p.h.
Fuel consumption (commuter driving) 28.6 m.p.g.	
Fuel consumption (open road).....	35 m.p.g.
Engine specifications	
Engine.....	4-cylinder, OHV, water-cooled
Displacement.....	66.4 cu. in.
Horsepower.....	40 hp. at 4,200 r.p.m.
Torque.....	50.5 lb-ft. at 2,800 r.p.m.
Bore and stroke.....	2.68 in. by 2.95 in.
Compression ratio	7:1
Chassis and running gear	
Transmission.....	4 forward speeds: 2nd, 3rd & 4th, synchromesh
Rear axle.....	swinging half-axes; transverse springs; ratio, 4.78:1
Front axle.....	trapezoidal half-axes, transverse springs
Chassis.....	central tubular backbone
Tires	5.50-15
Steering.....	3 turns, lock to lock
Turning-circle diameter.....	33 feet
.....	

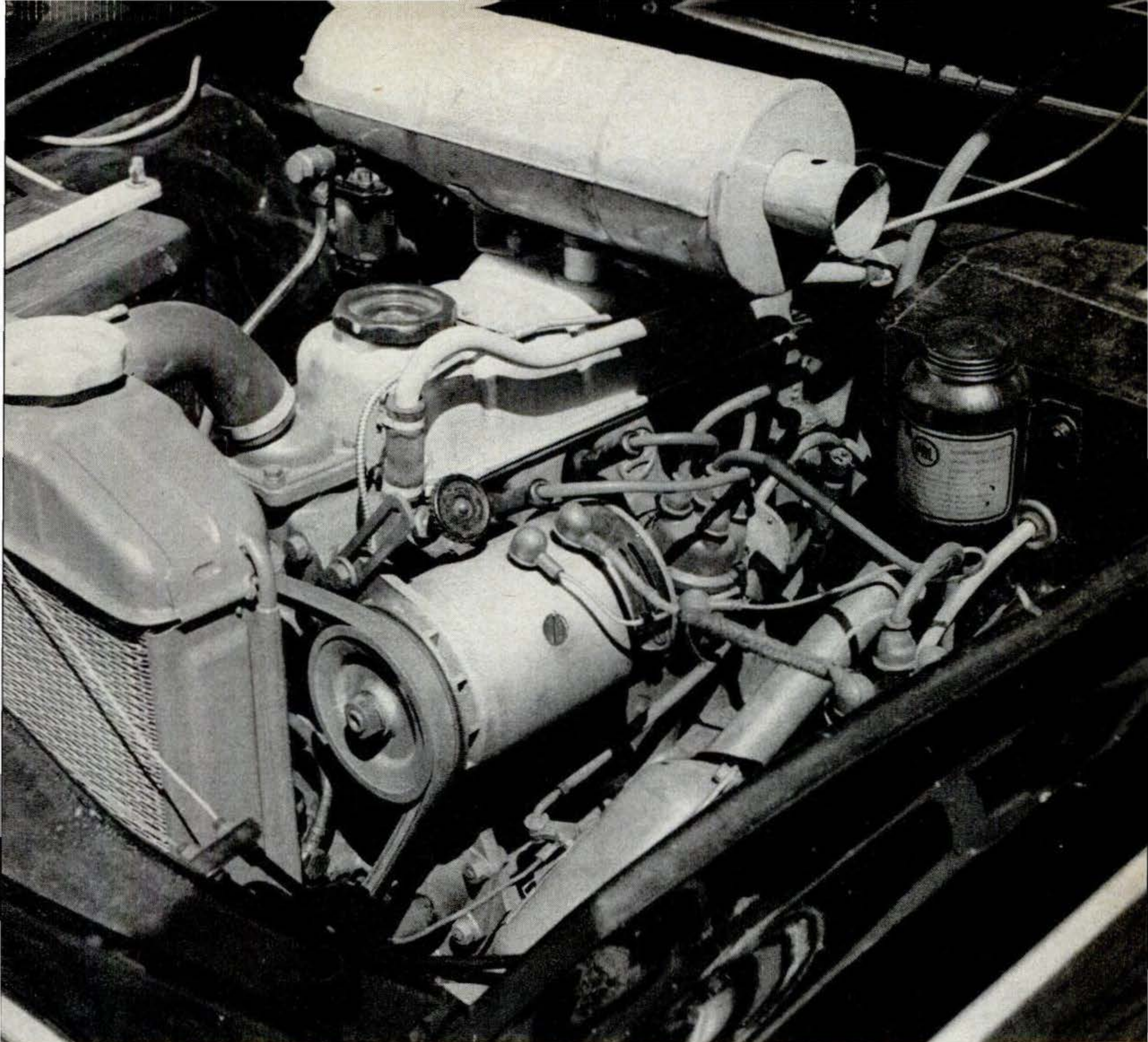

Aluminum engine block and head has wet cylinder liners and valve-seat inserts of steel.



TRUNK SPACE is generous. A small boy has no business being here, but this picture is just to demonstrate the ample luggage capacity.



VISIBILITY to the rear is unusually good for a small foreign car. Safety-glass rear window is interchangeable with the windshield.

Yes, the New Cars Do Take More Gas

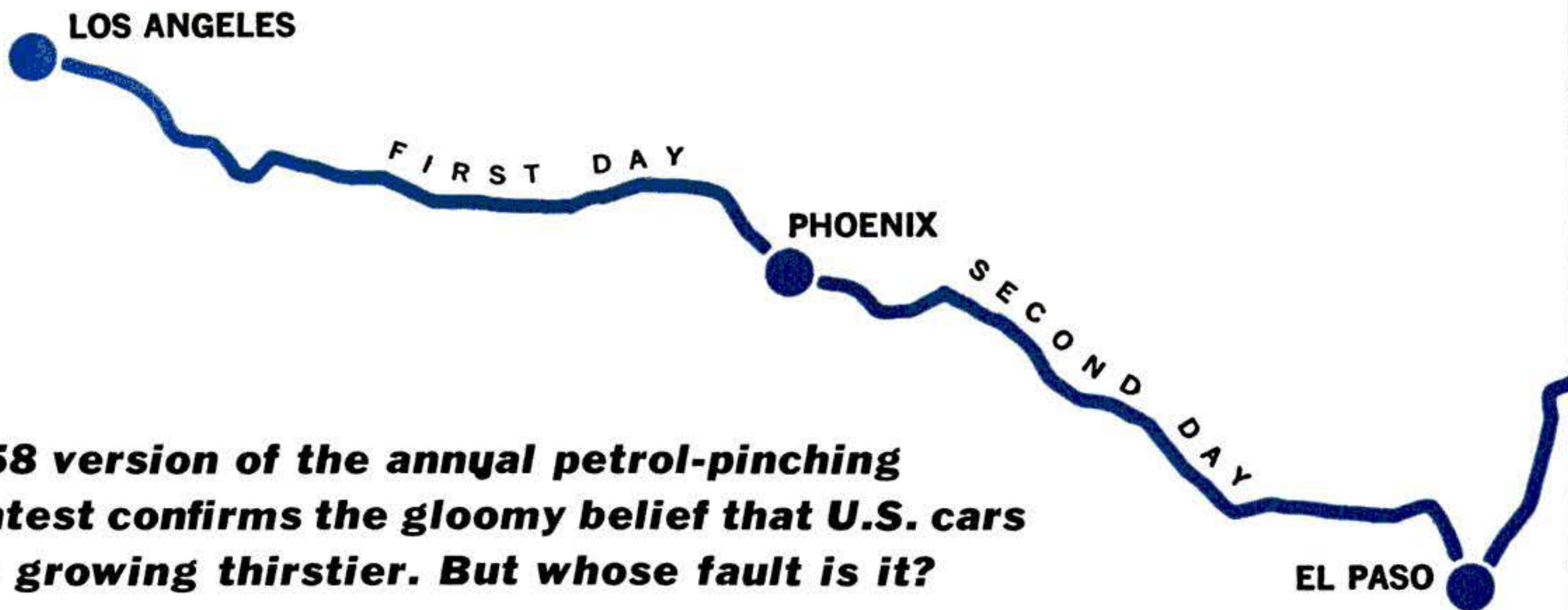

1958 version of the annual petrol-pinching contest confirms the gloomy belief that U.S. cars are growing thirstier. But whose fault is it?

THE Mobilgas Economy Run is a curious annual rite that, in the folklore of Detroit, is worth \$5,000,000 to the manufacturer whose cars chiefly win it. This value is supposed to derive from a wide-eyed public belief that the winning car has been largely weaned of a taste for fuel, and will run on virtually engineering alone. Such is the opinion, at least, of enthusiastic car-marketing men.

Public attitudes toward the Run seem less tidy. "Economy Run?" almost anyone may ask. "That's the one that half a dozen cars win, isn't it?" Another view is that it is a yearly ceremony calculated to suggest that the new cars are better than ever.

The skepticism comes from a general awareness that cars are increasingly hard to drive past the gas-station pumps. Hence the feat of driving a heavy, high-powered new car for several thousand hill-and-dale miles on an improbably small amount of gasoline becomes, to much of the public, a stunt bearing scant relation to reality.

This year's Economy Run will do little to dispel the dreamlike air. For the third year in a row the sweepstakes winner was

an Imperial—a 2½-ton, 345-hp. land yacht that glided from Los Angeles to Galveston while sipping fuel at the rate of 20.5821 miles per gallon. (Its victory was based on a score of 62.7188 ton-miles, this index being an abstraction defined as "the number of miles that a gallon of gasoline drives a ton of car.")

Cars of the Chrysler family—the Imperial, a Chrysler and a Plymouth—copped three out of the four class trophies; an Olds nosed out a De Soto for the fourth.

How meaningful are Economy Run rankings? An answer can be approached by first considering three preliminary questions:

- How can the high miles-per-gallon figures be made to jibe with the widespread impression that new cars swill down gas?

- Is there a mathematical flaw in a contest formula that repeatedly gives the top award to heavyweight cars?

- What does an analysis of the Economy Run figures reveal about the gas-drinking habits of American cars over the last two decades?

Exotic driving techniques. An Economy Run driver practices an art form that is subtle, demanding and exceedingly



SWEEPSTAKES-WINNING IMPERIAL at left (20.5821 m.p.g.) and second-running Chrysler New Yorker (21.0217 m.p.g.) cross finish line in Galveston, Tex., bonnet-to-bonnet.

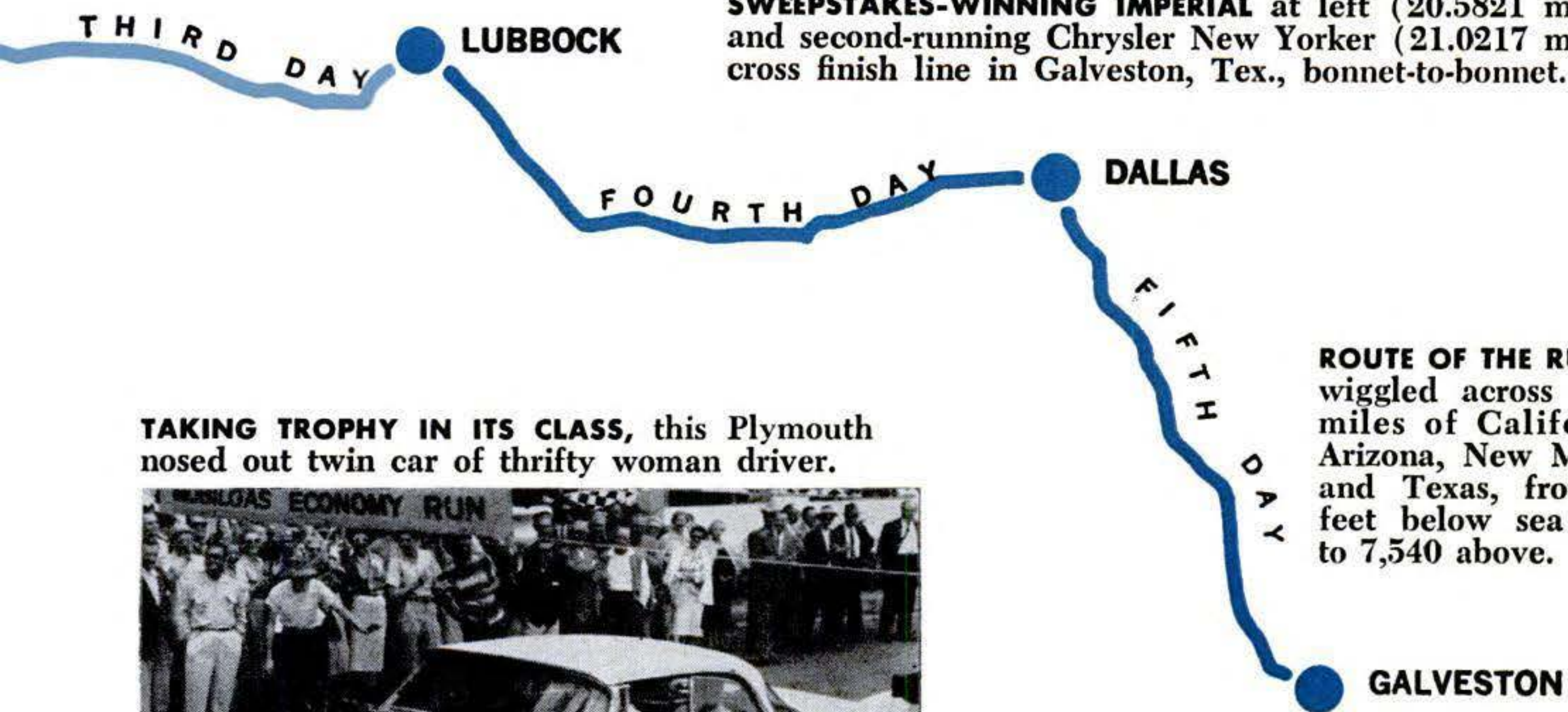

ROUTE OF THE RUN: It wiggled across 1,883 miles of California, Arizona, New Mexico and Texas, from 22 feet below sea level to 7,540 above.

TAKING TROPHY IN ITS CLASS, this Plymouth nosed out twin car of thrifty woman driver.



remote from ordinary around-town chauffeuring. His accelerator is of course *never* opened to that jet-spraying, yawning-barreled point where the engine roars with all its big-displacement majesty. But it's not just that a driver stays on the lean side of part throttle, outguesses every possible red light, and avoids the brake like the plague—though these steps are basic. He is also versed in tiny, cumulatively important tricks:

He keeps the windows up: less air drag. He keeps the radio antenna retracted: same reason. He uses matches instead of



OLDS 88 ENTERS WINNERS' CIRCLE, scoring top ton-mileage figure for Low-Medium Price Class, balking clean sweep by Chrysler Corp. cars.



DON'T WASTE A DROP: A driver puts ear to tank inlet to make sure gas won't get too close to top and overflow. A few wasted thimblefuls could spoil his chance to win a trophy.

the electric lighter: the generator would spend a spoonful of power in putting the watts back into the system. He keeps the radio and heater fan off: same reason. He even calculates about the windshield wipers: he uses them as little as possible if they are electric. But if they're vacuum, he runs them as much as his official observer will permit: vacuum wipers lean the mixture very slightly by admitting air to the intake manifold.

His car is freshly tuned to a knife edge and fitted, as rules permit, with a carburetor metering rod or jet one step leaner than normal. The axle ratio is the most favorable the rules allow; the automatic transmission is set for the quickest permissible upshift within the range of normal limits. Wheels are aligned meticulously. Brakes, drive train, and the wheel bearings have no trace of abnormal friction. True, the cars are inspected to make sure they are not unfairly prepared. But the system does not—and cannot—insure that they resemble the random, casually adjusted cars that we drive.

There is, then, no mystery about the Run's high gasoline mileages. Almost anybody could at least approach these figures—if he drove a beautifully prepared car in a bizarre, demanding and inconvenient fashion.

Are the rules right? Much tugging and hauling over the rules has attended the 15 Economy Runs held since 1936. Lightweight cars like Rambler 6, Willys and Henry J were permitted for a time and

then excluded. Overdrive transmissions were permitted and excluded. The rules at present are intended to let in only the cars the public mainly buys: five- or six-passenger sedans or hardtops, with engines exceeding 220 cubic inches, with automatic transmissions, and with (on eight-cylinder models) mandatory power steering and power brakes.

The ton-mile formula is supposed to permit fair comparisons between light and heavy cars. It has been attacked from several directions. Nontechnical critics argue that *any* handicapping is unrealistic, miles-per-gallon being the exact measure of a car's fuel economy. Why penalize medium and lightweights, they inquire, just because the heavyweights are fat with extra metal? Engineering-minded critics see flaws in the correction formula, and argue that a scientifically accurate compensation should include frontal area and other factors.

Engineers of the oil company that stages the Run concede that the ton-miles formula *is* inexact, and does overcorrect in favor of fat cars. (No car in the economical "Special" class ever won the Sweepstakes, and only one in the low-priced, relatively lightweight group.) The old formula stays on each year, though—it's convenient, not outstandingly unfair, and easily understood.

Are new cars really thirstier? On the basis of 15 Economy Runs, the answer is a clear "Yes." Analysis of the scores posted in past years shows the following:

- Average miles-per-gallon of all cars making the run varied very little from 1936 to 1955, hovering close to 21.8 m.p.g.
- Since then, fuel mileage has gone down startlingly. Average mileage fell 2.1 m.p.g. (10 percent) in 1956. It was also down in 1957, though not as much: 1.3 m.p.g., or six percent below the 20-year average. This year it sagged down to an embarrassing 18.7529 m.p.g.—almost 14 percent below the 20-year average.

To put it another way: Economy Run data indicate that for two decades the U. S. car traded advances in compression, engine design, and fuel for better performance and a larger package *while holding even on fuel consumption*. Then, in the last three years, the averages have nose-dived.

In partial defense of Detroit iron, some limitations on the meaningfulness

HOW THEY RAN IN 1958

(Cars Listed in Order of Standing)

LOW PRICE CLASS	Driver	Ton-Miles per Gallon	Miles per Gallon	Hp.	Cu. In. Disp.	Comp. Ratio
PLYMOUTH BELVEDERE	Pierce Venable	48.3264	20.0088	225	318	9:1
PLYMOUTH BELVEDERE	Mary Davis	48.1801	19.9897	225	318	9:1
CHEVROLET DELRAY 6	Gus Retzlaff	47.0738	20.6441	145	235	8.25:1
FORD FAIRLANE	Marshall Martin	46.8827	19.7775	205	292	9.1:1
FORD CUSTOM 6	Ivan Lewis	46.2543	20.8870	145	223	8.6:1
CHEVROLET BEL AIR	John Hartman	44.3255	18.7284	230	283	9.5:1
CHEVROLET IMPALA	Dorothy Retzlaff	41.2717	17.1787	250	348	9.5:1
LOW-MEDIUM PRICE CLASS						
OLDSMOBILE 88	Link Paola	50.5951	19.2377	265	371	10:1
DE SOTO FIREDOME	Myra Buchanan	49.2339	18.9471	295	361	10:1
EDSEL PACER	Don Rice	48.9044	19.2518	303	361	10.5:1
PONTIAC SUPER CHIEF	Lynn Paulette	48.3955	18.8017	270	370	10:1
EDSEL PACER	Loretta Colange	48.2209	19.0052	303	361	10.5:1
MERCURY MONTCLAIR	Fran Hernandez	48.1613	18.1621	330	383	10:1
BUICK SPECIAL	Joe Hill	45.7969	16.9445	250	364	9.5:1
DODGE CUSTOM ROYAL 500	Bob Donkin	44.2404	17.8137	305	361	10:1
DODGE CUSTOM ROYAL 500	Joan Fischal	43.4382	17.5490	305	361	10:1
STUDEBAKER PRESIDENT	Pete Novotny	43.3224	19.2608	225	289	8.3:1
HIGH-MEDIUM PRICE CLASS						
CHRYSLER NEW YORKER	George Alsbury	58.4928	21.0217	345	392	10:1
DE SOTO FIREFLITE	Hart Fullerton	51.9198	19.6573	305	361	10:1
MERCURY TURNPIKE CRUISER	Bill Stroppe	51.0536	18.8390	330	383	10.5:1
MERCURY PARK LANE	Verne Houle	48.4367	17.4186	360	430	10:1
OLDSMOBILE 98	Ray Brock	48.2714	17.4849	305	371	10:1
BUICK CENTURY	R. M. Flanagan	47.9027	17.6698	300	364	10:1
EDSEL CITATION	Art Rene	47.1114	17.2474	345	410	10.5:1
DE SOTO FIREFLITE	Ruth Doushness	47.0751	18.2869	305	361	10:1
HIGH PRICE CLASS						
*IMPERIAL CROWN	Mel Alsbury Jr.	62.7188	20.5821	345	392	10:1
CONTINENTAL	Danny Eames	55.8884	18.0737	375	430	10.5:1
CONTINENTAL	Nicky Griffen	55.3927	17.9628	375	430	10.5:1
BUICK ROADMASTER	Don Bridges	50.3234	17.4024	300	364	10:1

***Sweepstakes Champion**

Average ton-miles per gallon, all cars: 48.8693
 Average ton-miles per gallon, men drivers: 49.2908
 Average ton-miles per gallon, women drivers: 47.5447

Average miles per gallon, all cars: 18.7529
 Average miles per gallon, men drivers: 18.8598
 Average miles per gallon, women drivers: 18.4171

of Economy Run comparisons should be noted. One is the nature of the Run itself: Different cars are driven by different people over different routes in different kinds of weather. (The routes are believed to vary up to five percent in difficulty. And weather can matter; this year's poor average showing is attributed by some to persistent headwinds on one day's run.) Some if not all of these variables are corrected for, nevertheless, in a comparison of the *average* mileage of all cars.

A second partial explanation of the worsening fuel mileage undoubtedly comes from the exclusion, after 1955, of overdrive transmissions in favor of automatics. In the years that the two boxes

competed, overdrive consistently won. Several times identical cars differing only in transmission showed a four m.p.g. advantage for overdrive.

But the general public prefers the easy comfort of an automatic transmission to the frugality of overdrive. It also prefers—or has until lately—steadily bigger and heavier cars, power-parasitic accessories, and engines big enough to deliver neck-bending acceleration. (Times required to accelerate from zero to 60 m.p.h. have been nearly halved since 1950.) So if, as Economy Run figures indicate, the U. S. car is threatening to become a compulsive drinker, the U. S. buying public must shoulder at least part of the blame. **END**

Army hot-weather research reveals: New Ideas on Keeping Cool

Desert experiments show how to make the most of your body's marvelous built-in thermostat

By Philip Gustafson

ARM Y scientists, seeking new ways to extend the fighting potential of soldiers campaigning in hot climates, are showing all of us new ways to beat the heat. Their findings have begun to shoot holes in many old-fashioned hot-weather maxims.

Extensive experiments on human acclimatization to heat were conducted recently by Quartermaster Corps scientists and experts at the Boston University School of Medicine. They found that distressing responses to exertion in hot weather—high temperature, fast pulse rates, dizziness and nausea—can be dramatically reduced.

What does the trick is an almost magical process of acclimatization to heat, inherent in the human body but capable of being speeded or slowed by a person's behavior. Here are some basic findings about this human mechanism:

- Acclimatization normally begins on

the first day of a heat wave, progresses to full development by the fourth day.

- It can be helped by short, brisk exercise periods in heat, or lighter but longer work periods. (Even if you do almost no work, you acclimatize a little.)

- If you are in good physical condition you acclimatize most rapidly.

- Over-strenuous exertion at the first exposure is bad; it may cause disability for several days.

- Failure to take in enough water and salt may prevent acclimatization.

- Once achieved, acclimatization to heat is retained for about two weeks. It can be extended by regular workouts in the heat at two-week intervals.

To acclimatize yourself, especially if you work outdoors, here's what Army scientists advise:

Thoroughly condition yourself by repeated (but judicious) activity in the heat over a period of from three to five days. This is even more important if you spend much of your time in air-conditioned surroundings.

For the trained athlete, the activity period can run up to two hours of strenuous exercise. For the rest of us, it tapers down to much less. How much? Each individ-

Hot-Weather "Do's"

At the start of a heat wave, restrict your work to a minimum. Everyone must find his own tolerance. When to quit? Take your pulse. If it's over 140, it's time to knock off for the day.

On succeeding days, condition yourself to the heat with moderate exercise.

Stop at nature's danger signals. If you feel dizzy or nauseated, knock off. These are the first danger signs. Ignore them and nature has another—and still less pleasant—device. You'll faint.

Keep in good physical condition. This increases your ability to get along in the heat. But it doesn't excuse you from a regimen of acclimatization.

Keep out of the sun as much as possible.

Wear lightweight, light-colored, permeable clothing. Loose-weave, thickly woven materials are also cool even if they're dark.

Keep your weight down. The fat man is at a disadvantage in the heat. He has a smaller surface area for sweating per unit mass of heat-producing tissue, and more insulation (subcutaneous fat) to bar heat transfer to the surface.

Use anti-sunburn lotions. Those containing quinine absorb ultraviolet rays and do a fair job of preventing sunburn.

Wear thick-soled shoes as insulation against pavement heat. In extreme heat, take cold-water foot baths.



GOING NO PLACE on a motor-driven treadmill that keeps him trudging at a controlled rate,

this test subject in the Yuma desert is wired with thermocouples that report body data.

Hot-Weather "Don'ts"

Don't drink too much water too rapidly when you've been sweating profusely. When you sweat, you lose both salt and water. Sweat a lot without drinking water and your blood has too much salt in proportion. Drink too rapidly and you get too much water in proportion. This may lead to water intoxication—too much dilution in all body cells, including the brain cells. Convulsions can result.

Don't gulp a lot of salt tablets after excessive perspiration. Salt irritates the lining of your gastrointestinal tract. Instead, mix yourself a glass of salt water, or salt your food liberally.

Don't depend on cold drinks to keep you

cool. A cold drink absorbs some heat in the stomach but you can't drink enough to reduce the body temperature appreciably. But cold drinks do constrict the blood vessels in the skin. Thus you get a drop in the skin temperature which may make you *feel* cooler.

Don't wear belts and ties in hot weather. They cut off air circulation under the clothing.

Don't give way to the temptation of acquiring a Hollywood tan. Just being in the sun has the same effect on your body as a five- to 10-degree rise in the mercury. Suntan doesn't increase your ability to work in the sun. It merely keeps you from burning further.

Common Hot-Weather Fallacies . . .



That you're asking for a sunstroke if you go out in the hot sun without a hat. Actually you're usually as well off without a hat—air can reach your skin, cool by evaporation.



That you should eat only salads and other light foods. The requirements for nutrition on a hot day are the same as at any other time. But when you eat a heavy meal, more blood is needed in the viscera. This adds to the load of the cardiovascular system. So if you eat heavily, you may feel warmer for a while.



That thin, light clothes are always cooler and you should keep away from dark colors. Army experiments confirm that black is warmer than white; it absorbs more of the sun's rays, while white reflects. This is true of thinner, lighter material close to the skin. But thick, loosely woven dark clothing may be cooler than thin, light, but tightly woven clothing. Loose, dark clothing absorbs the sun's rays farther from the skin, while its permeable texture admits air.

That alcohol in itself makes you hot. All it does is supply calories which you burn instead of food.



That more vitamins are necessary. In desert experiments, there was no evidence of increased vitamin requirements.

ual must find out for himself. But there is one foolproof way of knowing when you've had enough. Count your pulse. When it goes up over 140 per minute, knock off.

Your body is stressed by two things in hot weather: the heat load imposed on it by the environment, and the heat load added to that by exercise. The doctors found dramatic body responses to temperatures in the Arizona desert that prove this point.

They checked pulse rates as high as 186 in men who walked for the first time at four miles an hour in 120-degree F. weather. That same walk at 77 degrees resulted in pulse rates of 115 to 120.

A man's ability to work is radically reduced by the heat load of 100 degrees. A 150-pound man can walk at three miles an hour without a pack for two hours a day and stay within the limits of endurance. If he steps up the pace to four miles an hour, he courts danger. At six miles an hour, only fit men can last six minutes.

Here is how you adjust to heat, even if you never go west of the Mississippi or swelter out anything worse than a Yankee hot spell: The body mechanism is beautifully equipped to deal with hot weather, even in temperatures up to 120 degrees—if you don't exercise too much. Its main

[Continued on page 214]

Popular Science Editor Howard Allaway, right, receives gold medal from Daniel D. Mich, Editorial Director of Look magazine, last year's winner.



Popular Science Wins Year's Top Magazine Award for Public Service

The year's most prized award for magazine editorial achievement, the annual Benjamin Franklin Award for public service, was presented last month to POPULAR SCIENCE.

POPULAR SCIENCE was designated for this honor for its publication of a series of articles, "Straight Talk to Parents," which appeared in the magazine from March through December last year. The articles counseled parents on how to direct their youngsters toward educational opportunities leading to profitable and useful careers, particularly in scientific and technical fields.

POPULAR SCIENCE, the judges commented, "... presented one of America's greatest problems in a sharply focussed series of articles directed to the group who will have to do the most about it—the American parents. . . . As opposed to generalities on educational theory, these articles provided real tools with which to handle the here and now . . ."

Besides a gold medal and scroll, presented to Editor Howard Allaway, certificates were awarded to the authors of the individual articles: Senior Editor Martin Mann, who also coordinated the entire series; West Coast Editor Wesley S. Griswold; Associate Editor Erik H. Arctander; and free-lance writers David Lindsay, Vance Packard and John Kord Lagemann.

Previous winners of the public service award, which is administered by the University of Illinois, were *Ladies Home Journal*, *Redbook*, *Woman's Home Companion*, and *Look*.

The Benjamin Franklin Award is the third major magazine prize won by POPULAR SCIENCE during the past year. Others were a "Maggie" Award, made by the Pacific Coast Independent Magazine Wholesalers Association, for the "Popular Science Reference Library" series of tear-out booklets, as demonstrating "the most original creative spirit" during the year in the magazine publishing field; and the annual National Safety Council public-interest award, which PS has won eight years in a row, for articles promoting highway safety.



How Dangerous Are Those Small

The little cars are mice in a herd of elephants. How often do they get stepped on? What happens to them? Here are facts from a new study by crash researchers

By Martin Mann

THERE'S this little Volkswagen stopped for a red light. Up comes a big Buick, too fast. It slams the VW in the left rear at 35 m.p.h. The little car takes off on a 72-foot slide diagonally across the road into the grass.

Damage to the VW: cracked block (it's a rear engine, remember) and driver's seat torn loose. The driver walks away.

Then there's another little Volkswagen in San Francisco. It crashes head-on into an old Caddy, gets squashed from the rear by a third car.

This VW ends up a smashed tin can. Two wreckers work an hour pulling pieces apart to get at the driver's body. In the American cars—one driver is not hurt at all; the other is injured slightly.

Those two accidents, which actually happened, are what many Americans worry about when they consider buying a small foreign car.

Which case is typical? Will you walk away or get mangled? Does the import's small size and light weight make it a special hazard on the highway?

The U.S. public last year bought 200,000 European bugs. This year one out of every 16 new cars will be stamped Made in Germany or Sweden or England or France or Italy. Sooner or later there'll be many more small cars, aside from the Rambler, stamped Made in USA.

Are they safe?

Now, for the first time, there is an answer. Not a solid, 100-percent-guaranteed verdict. But a dispassionate, scientifically based appraisal that shows pretty clearly which way the decision will go.

POPULAR SCIENCE asked Cornell University's Automotive Crash Injury Research group to take a hard look at small-car safety for you. ACIR is one of the country's main accident-research centers. With government-industry support, it collects and analyzes crash reports from 16 cooperating states. Its findings, persuasively evangelized by Director John O. Moore, helped put Detroit on the safety kick several years back—seat belts, padding, positive door locks.

Fast-talking, energetic Boris Tourin, supervisor of ACIR's Technical Department, says, based on what he prefers to call a "preliminary survey":

- Small size and light weight are *theoretically* a hazard. The little cars are mice lost in a herd of elephants.

- But other factors compensate. In certain accidents, small cars come through better. In others, big cars are better.

- The overall picture shows big cars very slightly—but not positively—safer.

How can you tell? There are at least four ways to gauge the safety of a car.

1. Look at its construction and design in the light of elementary laws of physics.
2. Drive it.
3. Crash-test it.
4. Analyze the results of actual accidents.

POPULAR SCIENCE and the Cornell group applied gauges 1, 2 and 4 to small cars. Nobody, so far as PS can discover, has used gauge 3; crash tests are very expensive.

The car. It's small, it's light, and it's lean. Those attributes, beloved by owners, affect safety in these ways:

- Common sense, reinforced by Sir

Cars?

MOUSE GOT TRAMPLED.
Chevy hit this VW head-on, both doing 55. In VW, three dead. In Chevy, two badly hurt.



Isaac Newton, tells you that a light object gets the worst of a collision with a heavy object. Energy works the harm. The heavy object has more energy, which it expends by crumpling the light object.

- The small passenger compartment offers less room for you to flail around in. Your head is always close to something to bump into.

- Among the frills omitted are safety frills. Safety door locks, seat belts and crash padding, which are either standard equipment or readily available options on the Detroit product, are not so easy to come by in foreign makes. Saab has both the locks and a "collapsible" dash. The Renault has a padded "collapsible" dash, while Peugeot puts some foam rubber on the dash. Belts are offered by Renault, Peugeot and VW.

Add it up and you have apparently indicted the small car as a poor risk. But it's a theoretical indictment. What happens in practice is something different.

The driving. How does it feel to be a mouse among elephants? POPULAR SCIENCE editors have been check-driving small cars for years. I tried them, too.

I took a couple of bugs into the New York area's worst traffic, which is plenty bad: Fruehauf-loaded turnpikes; long, narrow under-Hudson tunnels; Cadillac-and-taxi-choked city streets; suburban blacktop on a Saturday afternoon. Here's what it's like.

Looking out the windshield, you can't tell you're a mouse among elephants. Bigger cars do not overwhelm you. Terrifying tunnels, with trucks that always seem about to fall over on you, are no sweat after all.

It's the rear view in the mirror that shocks you. All you can see of a following Caddy—even 10 car lengths to the rear—is bumper and dagmars. You're a mouse!

There are petty nags at your safety conscience, as well. The clutch and brake pedals are too small and too close together. The splash from passing cars on a rainy day inundates you so heavily you need a periscope. Yet you climb up from behind the wheel with the standard opinion: This is a pleasant and practical car, fun to drive and safe to drive.

The accidents. You can theorize about safety all you want to from design studies and driving tests. What really counts is performance on the road—the accidents a car does or does not get into, the harm caused to its occupants.

One crucial point—is the small car accident-prone?—stands unsettled now and will remain so for years to come. Not until many more crashes have been recorded and analyzed can the experts tell whether small-car crashes are disproportionately frequent or infrequent, whether you stand more or less chance of getting involved in a smashup simply because you ride a small car.

Two other questions—both important—can be answered, even if only tentatively:

1. What kinds of accidents do small cars get into?
2. What happens to the people inside?

You need both answers, together, because some accidents are very common (crumpled fenders) but not very dangerous, while others are very dangerous (trucks toppling on cars) but not very common. It's the combination of exposure

Accident figures show small cars are more likely to overturn

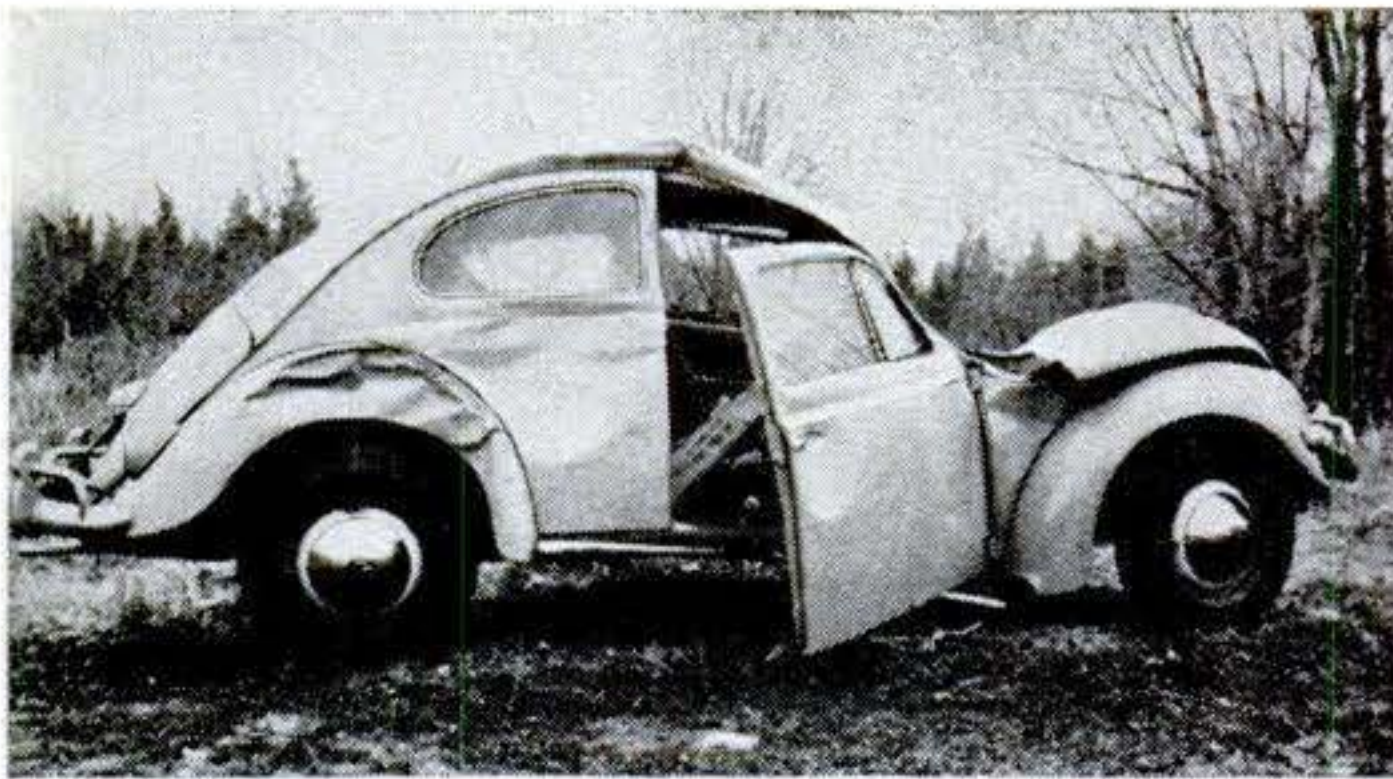

ROLLOVER after glancing off a tree (driver fell asleep doing 50) left a VW like this. The driver was pinned inside, cut and bruised.



TREE did this to a Hillman that swerved to avoid a dog in the road, went out of control at 40 m.p.h. The tree, 10 inches thick, split.



WINDSHIELD POPPED OUT WHOLE in the Hillman-vs.-tree accident, protecting driver and passenger. They were injured, but not seriously.

and risk of injury that tells the story.

Answering such questions is the specialty of Tourin and his group at ACIR. From their detailed accident reports—four-page police forms, photos, medical records—they and their IBM machine have settled arguments like: Is speed the sole killer? (no) and: Are new cars safer? (yes). They gave their fancy statistical treatment to small-car accidents. The classification was based on weight, which means that a few Detroit jobs (Henry Js and old, old Studies) were sprinkled in with the bulk of VWs, Renaults, Anglias, and the rest. Here is what they found:

Kinds of accidents. The pattern is clear—and surprising. Small cars tend, not to get run over by the big ones, but to roll over by themselves.

Collisions are still the most common type of accident, for little cars (2,500 lb. and less) as well as for the big ones (3,000 lb. and more). But the proportions are strikingly different. Of all accidents involving light cars, roughly 60 percent are collisions, 40 percent are rollovers. For heavy cars, the split is 80-20. So if you have an accident with a light car, it's twice as likely to be a rollover.

This does *not* mean that the light cars get hit and then roll. They go off the road, out of control, and roll—all alone. Case K30061 is typical.

A '57 Renault was burning up U.S. 6 at 60 m.p.h. early one wet morning last July. The driver veered onto the soft shoulder and lost it. The Renault skidded back across the lane to the dividing island—soft dirt. It flipped onto its side, then skidded that way across the island and the opposing lane to the far shoulder.

The car was badly banged up, but the doors did not open. The driver was unhurt.

Why do they roll? Your guess is as good as anybody's. It could be the fast steering ratio, light weight, or small wheels. Maybe the center of gravity is higher than it looks (tread is narrow, wheelbase short). Whatever the cause, rollovers—even end-over-end—are a distinctive trait of small-car accidents.

The injuries. That's the next question. If you crash, would you come through better or worse in a small car?

Again the Cornell group matched ac-

[\[Continued on page 210\]](#)



"How much is my place worth?" you may ask. "Sorry, can't talk," they say, and go away.

If the Highway Builders Want Your Home

Thousands of homes are being seized to make way for new roads. If yours is on the list, should you accept the inevitable—or fight?

By Edward D. Fales Jr.

- *To build 129 miles of turnpike, Connecticut recently seized 2,550 homes.*
- *To build a projected 41,000 miles of U. S. super-roads, 700,000 parcels of land must be taken.*
- *Two million pieces of land, many with houses on them, will be needed for roads in the next 14 years.*

YOUR doorbell rings. Two men you never saw before are there. "We have been sent," one says, "to appraise your home."

"My home?" you repeat, unbelievably. "That's right." And then they explain, in as friendly a way as they can, that a new road—or school or airport—is going to be built where you live. Some of your land is needed, possibly all. And your

The Government does everything it can to

You can't stop the dozers. Even while you're in court, the engineers can start work on your land.

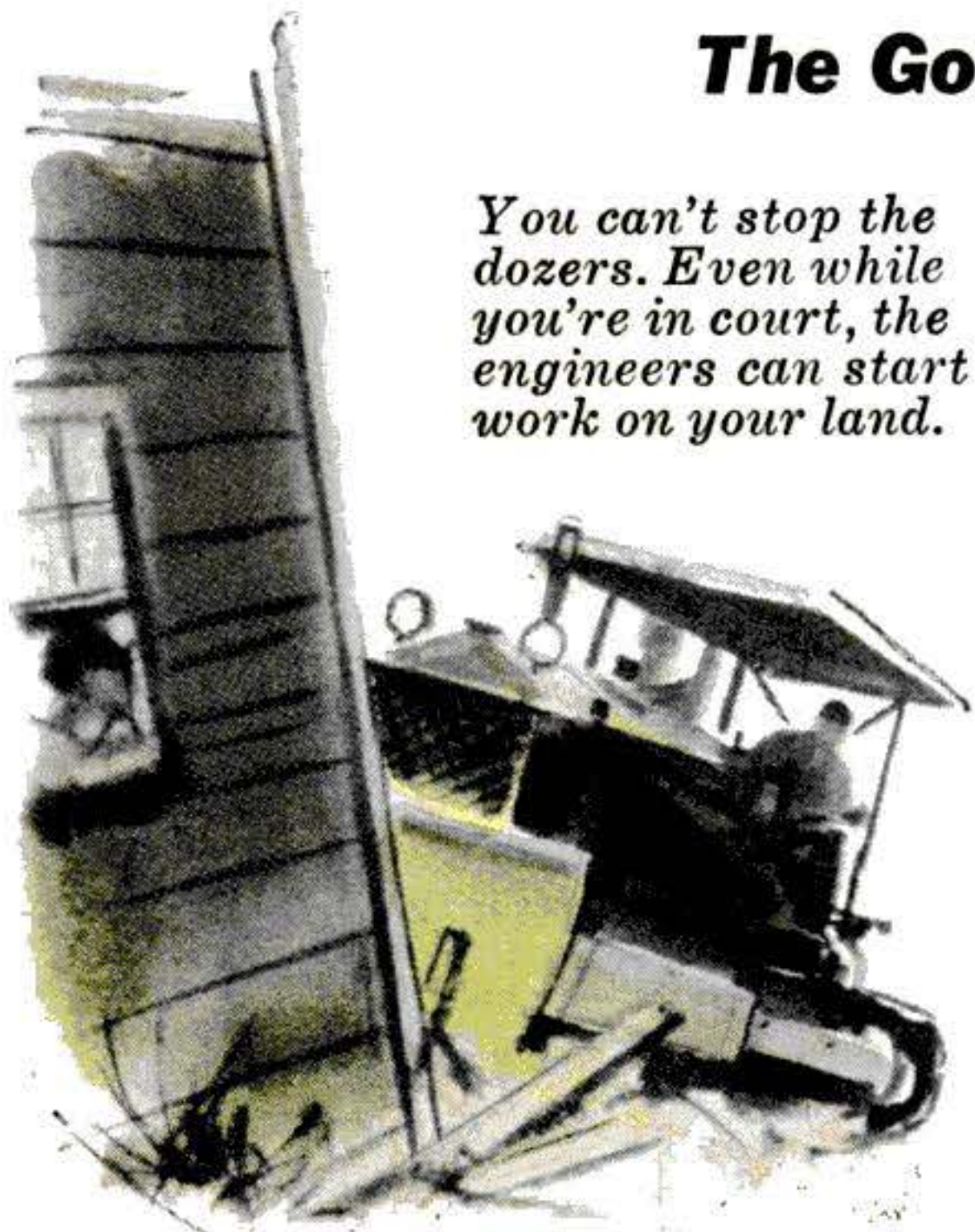

house must be torn down or moved away.

You gulp and try to think. This must be a joke. You've worked, and saved, and planted . . . But it isn't a joke.

And sure enough, in six months perhaps, your home is only a memory.

Practically unnoticed, this sort of thing has been happening to thousands of U. S. families. Those new turnpikes you use so comfortably and safely were built on land taken from your neighbors. Property "quick-taking" is under way on a scale never before known. It's the price we're paying for population growth, and progress.

You may say: "Oh, but it could never happen to me." That's what thousands thought who recently have seen bulldozers rip their homes apart.

"But this is America," you say. "No one can take my home if I don't want to sell. I'll get a lawyer. I won't budge."

A lot of home owners have felt that way. But only two or three in 100 keep fighting when the final showdown comes. That's because the engineers, appraisers and project officials generally do everything they can to give you a fair break. They're not trying to be altruistic; they've got to keep your good will in order to succeed with *future* projects.

Let's look at specifics. Let's suppose you own a house that cost you \$12,500 six years ago, worth maybe \$17,500 today.

One day an engineer draws a pencil line on a map. The line represents a new road that will connect two superhighways 50 miles apart. The line represents months

of careful location study. Putting the road anywhere else would double the cost and also result in dangerous curves. As drawn, the line runs right through your property.

Who owns the land? How can public officials doom your property without even consulting you? Few of us know it, but none of us have absolute control over our own property. This principle of law goes back many centuries. We hold land subject always to public welfare.

Today when whole cities are turning inside out (and other cities are springing up on lonely farm land) space must be found in a hurry, not only for roads but for new schools, parking lots, housing projects, flood control, power lines, airports, missile sites.

To cope with the problem, legislatures have given dozens of government agencies—national, state, county and city—absolute power to take land by condemnation.

There are only two requirements: (1) the public must actually need your property, and (2) it must pay you a fair market price. Utility companies are authorized by law to take land on the same basis.

Do you have any say about this "public necessity"? Theoretically, yes. Actually, in many states, no. Often you can demand a public hearing—if you find out that a project is coming your way. That's a big "if." Engineers often work in deep secrecy, for two reasons:

- To keep the public from getting worked up over a project, especially when the final location has not been decided.

- To head off land speculators who gobble up land and prepare hasty "plans" for "developing" it, in hopes of holding up the state for a big bite of the taxpayers' money.

Hearings are always held on federal-aid highway projects that affect city areas. But on many other projects no public hearing is held, even if you demand one. This is a bit of high-handedness that planning agencies now are getting away from, however, and you'll see more hearings in the future.

How do you find out? Unless your town has a live-wire newspaper, you may never know your land is to be taken until the appraisers arrive. Wisconsin

give you a fair shake—but you won't get rich

sends out a "nice three-page letter," but most states and cities remain mum. One tip-off: You may see surveyors around. This is not a sure-fire clue. It is just barely possible they could be decoys, sent to mislead speculators (who are a tremendous headache to conscientious public officials). Or they may be working on another job entirely.

Who are the appraisers who come to your home? Usually at least one is a local real-estate expert. Their orders are to appraise your property as if it were their own, to be fair, and to remain mum. "How much is my place worth?" you may ask them. "Sorry, can't talk," they say, and go away, taking their notes.

How fair are they? Most people find them quite fair. Appraisals are based on careful formulas.

What happens next? In a few states you get a court notice and a price offer by mail. But in most states a negotiator calls in a few days. He is a friendly chap, hired for personality, fairness and business sense. He may tell you that, based on the appraisal, he can pay you \$16,500. If you can prove that the appraisers overlooked some items, you may end up, after some dickering, with around \$17,500. (In some states negotiators do a little horse-trading with you. But this is now forbidden on federal-aid projects.)

Can you have a lawyer? Yes, and if you have any real reason to doubt that procedures in your area are fair, you should have one. A lawyer may remind you of things you might not have thought of: those two trees you planted, or the lawn you carefully sodded.

U. S. roads experts say, however, that in many states, where condemnation procedures are run on a very high plane, where they bend over backward to be fair, you may gain nothing by having a lawyer to represent you on highway-condemnation projects.

In any event, you don't have to agree to the state's offer at once. Some negotiators call three or four times. You have time to think and get receipts showing improvements you've made.

But within two or three weeks you must decide: Will you take the offer, or will you be one of the few who reject it?

If you accept, you sign an agreement, get a check for the whole amount within 30 to 60 days, and also get a deadline for moving. This may be from 60 days to two years. If you stay very long you rent your house from the agency that's bought it.

Suppose you refuse. The state files condemnation proceedings. You'll be summoned to court to tell your side—and now you definitely do need a lawyer. The court names an impartial board of review, or a referee who may be a retired judge or a real-estate expert. The referee, or board, now studies your case and recommends a price to the court.

But what if you're still unsatisfied? You go to trial—either with or without a jury, as you wish. Now you're at the end of the trail. The jury's finding is final. It may be more money—or it may be less than the state offered you. And if it is, you're stuck with it.

How often do property owners win? Generally about half of the time. If you win, some states will pay court costs and even part of your lawyer's fee. But if you lose you may pay, and these costs

You won't be reimbursed for inconvenience, sentimental attachment to your property, or noise.

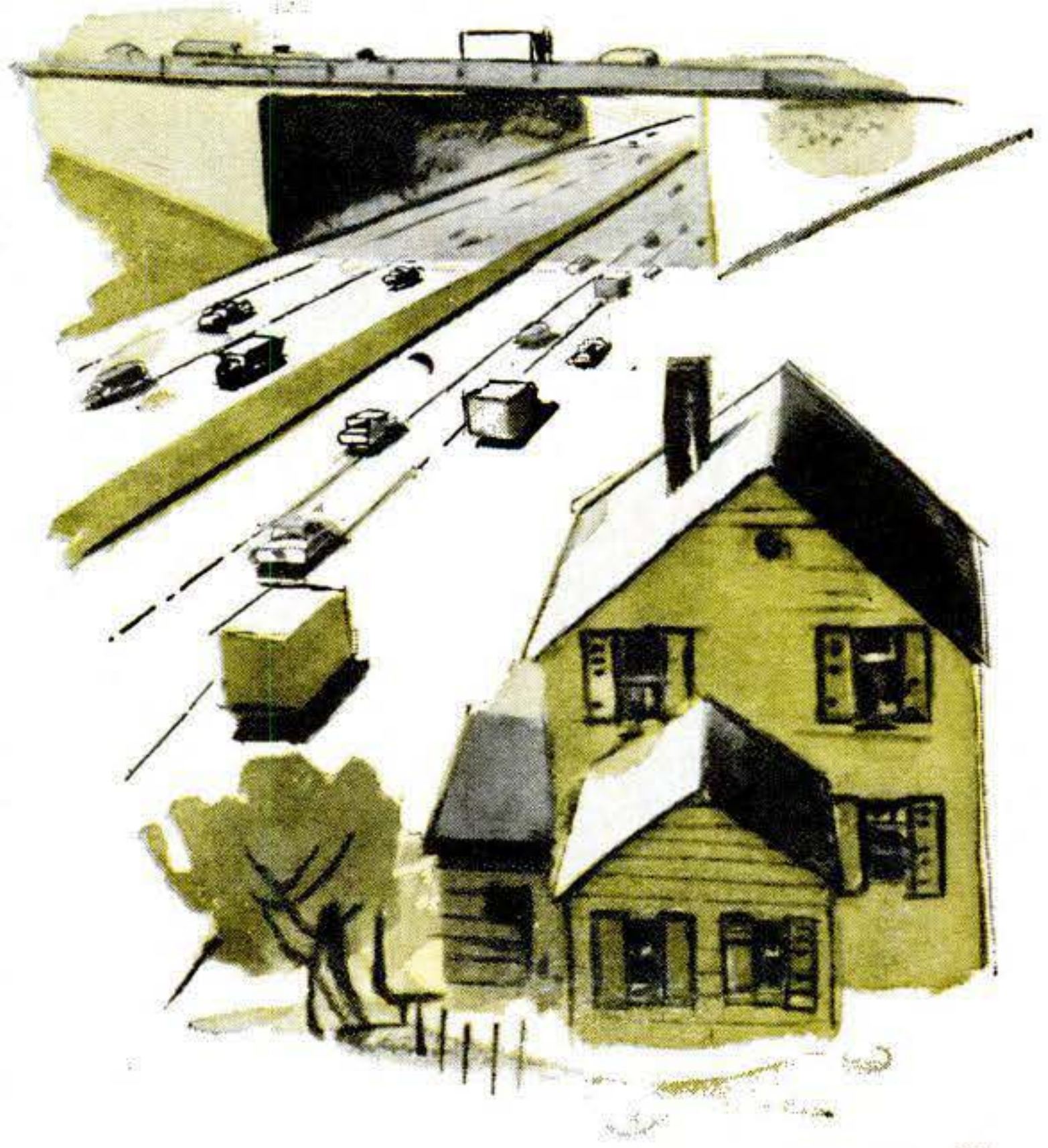

You may be able to take your home with you. But house-moving is costly; often it doesn't pay.

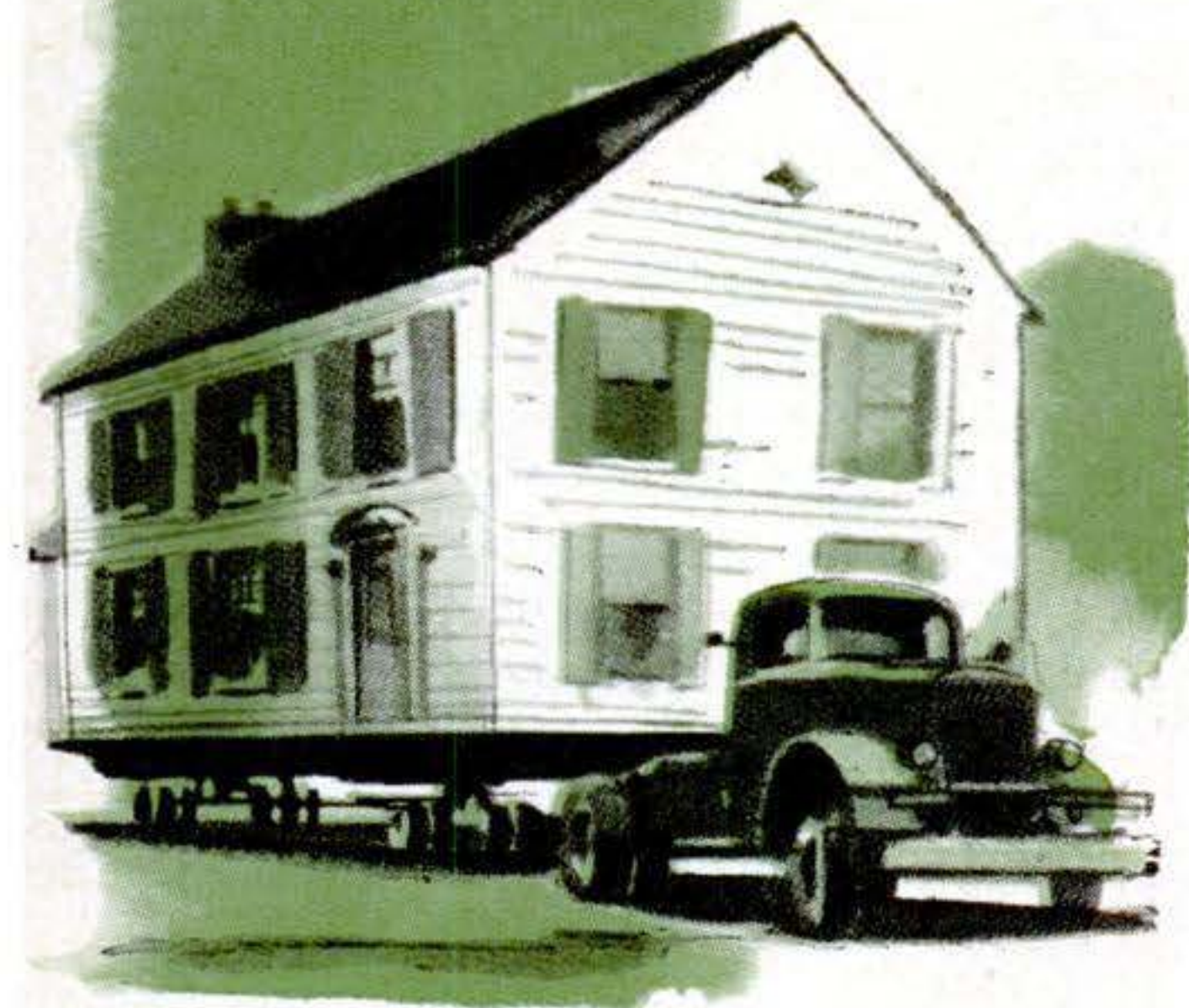

run from \$200 to \$2,500. A few states pay your costs, win or lose.

Suppose only part of your property is needed? Then you are paid: (1) for the part actually seized, plus (2) damages for loss of value on the remaining part.

But there are several things to remember. You are never reimbursed for inconvenience, sentimental attachment to your property, or noise.

You can't stop the bulldozers—even if you go to court! In fact, the engineers can start pushing dirt around on your place even while your case is being heard. As a matter of good judgment, however, they usually make every effort to avoid doing this.

Under our laws, the project engineers can apply to the courts for an order of immediate possession while you are appealing. This is invariably granted. Meanwhile the state must post with the court a check for the full amount of its offer to you. You can claim this at any time during the appeal without hurting your chances of getting more. (But if a jury should cut your award you'd have to give some of it back.)

What happens to your mortgage? Usually the state pays it off—and any loans or back taxes—then pays you the balance of your award.

Suppose you had a GI loan? Usually you can get a new GI loan to buy another house.

Do you have to pay federal income tax on the money you receive? Not if you reinvest the full amount in another house,

within 18 months. (Check your district Internal Revenue Collector for details on this.) Otherwise you must pay capital-gains tax on your theoretical profit—the difference between what you paid for your house and what the state paid you for it.

Can you make money on the deal when a government agency takes your property? It's virtually impossible. Appraisers are shrewd, and the courts are learning the tricks of speculators.

You may come out quite well in the immediate settlement. For one thing, you'll save the real-estate agent's fee you would probably have to pay if you were selling your house voluntarily. But remember, you still have to move and get settled, and none of these expenses is paid. Owners whose homes have been condemned say you may end up even, if you're lucky, or perhaps from \$500 to \$2,500 out of pocket, depending on how many adjustments you must make to get your new home as comfortable as the old one. Balancing this, you may end up in a newer or slightly better house.

If you buy a new house that's a little better or newer, of course, you may find yourself taking a new mortgage. One young couple recently got \$14,000 for their house, took on a \$4,000 mortgage and moved into an \$18,000 house.

Can you take your house with you? If it is movable, this can often be arranged. Some states first buy your house, then put it up at auction. You can buy it back and move it. Example: You might be paid \$17,500, then buy your house back for \$7,500.

Don't expect to make money this way, though. House moving is expensive. By the time you buy a lot, dig a new foundation, pay the house mover, put in plumbing and landscaping, you should break about even.

Some states go to great lengths to help you; others don't—you're strictly on your own. But California, which has moved thousands of houses, has even developed new land, putting in water and sewer lines for the transplanted homes.

Will you get cheated? It's not very likely. Some older couples suffer tremendous mental distress when sentimental ties are shattered. But our public engineers honestly feel that—monetarily, at least—most awards are eminently fair. **END**



A Safety Expert Takes a Hard Look at Turnpikes

Have engineers made our turnpikes as safe as they can be?

Here's a report on their successes—and dangerous failures

By Paul W. Kearney

*Author of *I Drive the Turnpikes—and Survive**

BILLIONS of vehicle miles are evidence that a modern turnpike is from 2½ to four times safer than an ordinary public highway. So, logically enough, these new roads have become the master pattern for the 41,000-mile network of super-roads now abuilding.

Despite their superlative safety records, turnpikes still have shocking crashes. Which gives rise to a pertinent question: Does turnpike experience suggest ways in which they can be made even safer?

The answer is a flat Yes.

The turnpike has already altered conventional accident patterns. On pike after pike today, the No. 1 accident cause is Driver Asleep. Closely allied with this fact is another: By far the commonest public criticism of toll roads is that they are monotonous. These two facts are inseparable—and they account for far more expressway troubles than that overworked bogey, Speed.

The following criticisms of toll-road design, it should be noted, are the observations of one who has racked up 85,000 miles on all existing pikes between Maine and Texas. Opinions have been liberally fortified by interviews with both state troopers and toll-road management officials—the men most acutely aware of the shortcomings that exist now.

In this light, here are six major indictments of modern turnpikes. They are worthy of the most careful study by those who are planning our new interstate network.

1 **Faulty crossover protection**

The narrow median strip, without an effective barrier, is the most universal and serious fault. Eighteen years ago, when the Pennsylvania Turnpike opened, its 10-foot center island was deemed adequate—indeed, we were still blithely building “motor parkways” with nothing but a paint stripe to separate opposing

"The narrow median strip, without an effective barrier,



CENTER STRIP 56 feet and wider separates opposing traffic lanes of the Ohio Turnpike. A deep ditch runs down the middle portion.

traffic. But a 10-foot grass patch became as impotent as a painted line for keeping oncoming drivers out of each other's laps. And by 1955 the Pennsylvania pike saw one-third of its fatal accidents, and 42 percent of its deaths, from head-on collisions after crossover.

The basic question is not why they crossed over, but why they were able to? Designers of later extensions on this pioneer pike not only perpetuated the blunder of the too-narrow median—they for-

sook even that, on the newest extension, in favor of a concrete curb that is too narrow and too low. For years cars have been mounting a higher barrier on some of the 40-m.p.h. Long Island parkways—where it was added as a lame second thought after gruesome experience.

Center islands that are too narrow, or completely unprotected, prevail on the Maine, Florida, Kansas and Oklahoma turnpikes. After all these years of experience, this seems inexplicable—especially when you drive along and note the number of fresh tire tracks where cars have gone clear across. The troopers on all of them confidentially admit that they have far too many crossovers.

Even the famous New Jersey Turnpike has only a 20-foot median. But it is now adding miles of steel barriers on stretches where experience has been bad. Both the Garden State Parkway in New Jersey and the Connecticut Turnpike have gone in heavily for medial guard rails, especially on curves and in congested areas where exceptionally high land costs restrict the width of the right of way.

Garden State has also moved in the other direction wherever possible with a center island ranging from 100 to 600 feet

Safety Audit: Turnpike Debits and Credits

Ohio Turnpike. Twin bridges are used on all overpasses, and on these bridges the pavement widens six feet. This is psychology applied in concrete: A bridge rail too close to the driving lane forces timid drivers onto the center stripe.

This is the only turnpike that gives printed information on available motels within 5½ miles of each interchange—a much-needed service for travelers.

Indiana Toll Road. Heating pipes in the concrete at toll booths keep these areas free from ice and snow.

West Virginia Turnpike. In contrast to the dungeon-like illumination of the seven tunnels on the Pennsylvania Turnpike, the light-

ing of the Memorial Tunnel on the West Virginia is superb. This is far more important on bright days, especially with snow on the ground, than at night. This tunnel is monitored by four TV cameras with viewing screens in police booths.

Oklahoma's Will Rogers Turnpike. Their answer to the moot question of center-island restaurants was to build a dramatic eating place at Vinita right across the traffic lanes. Escalators take patrons upstairs from entrances on either side of the pike.

(The Kansas and Florida turnpikes and the Garden State Parkway all favor the center-island service plaza at grade level, with cars entering and leaving via the fast lane. Florida and the Garden State have had no accidents from this dubious practice; Kansas has had a few minor ones involving cars entering the areas, but none on leaving.)

New Jersey Turnpike. Two early pioneering contributions of this "Queen of the Turnpikes" are its fine nonskid surface of asphaltic-concrete and its wide use of overhead directional signs on which the information is unmistakably clear. On fast roads there

is the most universal and serious turnpike fault”

in width. In addition, it uses “split-level” construction, with traffic lanes in one direction on a different elevation from opposite lanes. Indeed, on many parts of the Garden State you can’t see the opposing traffic at all. The Ohio Turnpike and the New York Thruway have adopted this sound principle where the terrain permits.

Where conditions—or inertia—prevent wide separation, the Ohio and Indiana turnpikes offer a good alternative: the depressed medial strip. Although their dividing mall is a generous 56 to 100 feet wide, it is further safeguarded by being ditched in the center to a depth of three or four feet. This makes it very difficult for a car to cross over, gives drivers a comfortable feeling of security, aids drainage, and is a logical place to push snow in winter.

Several state highway departments have experimented with the Floribunda rosebush barrier which, in repeated tests, has effectively stopped cars at speeds up to 70 m.p.h. Cheaper and safer than the steel guard rail, its main drawback is that it takes three to five years to get the bushes into full growth. Trees do not make satisfactory safety barriers; they are killers in collisions.

2 Inadequate right-hand shoulders

This is a mistake that the early Pennsylvania Turnpike commendably avoided, but which newer pikes thought up for themselves. On the greater part of the Pennsylvania pike you can not only pull a disabled car off on a paved shoulder, but there is ample room on the berm beyond to get well out of the way of passing traffic. This is a godsend to truckers and motorists alike. But newcomers to the pikes, as well as some of the designers, seldom appreciate this feature until they discover that no less than 10 percent of the fatal accidents on the busier toll roads involve one car standing still. This is five times the percentage of such accidents on public roads.

The relatively new Massachusetts Turnpike is an outstanding offender in this respect. Not only is a disabled car pinned to the shoulder by a low cable fence, but the shoulder is exactly the same color and material as the driving lanes. The only demarcation is a solid white stripe, and strangers commonly mistake the shoulder for a driving lane despite newly erected warning signs. Simi-

should be no moment of doubt in making a decision.

Jersey innovations include flashing neon signs warning of Fog, Ice or Accident Ahead; a special fog lighting system; and horizontal yellow strips across the driving lanes approaching toll booths as an additional warning to slow down.

Garden State Parkway. This is the only expressway that has roadside telephone booths between service areas. These are so popular that the telephone company collected \$47,500 last year from 13 booths (of which the Parkway gets 20 percent). Twenty more are now being added.

A current experiment worth watching is the use of a deer repellent on trees along the right of way (it’s impractical to build fences high enough to curb these champion jumpers). This is a problem in many states: The New York Thruway had over 600 deer accidents in one year with an average property damage of \$300 per car.

Florida Turnpike. Problems here include an occasional alligator dozing on the pavement, and buzzards whose slow takeoff has smashed

more than one windshield. To forestall the gathering of buzzards, troopers on this pike now carry trench shovels and are required to bury immediately the remains of any dead animal.

A debit that the Florida and Connecticut pikes share is speed-change lanes that are too short.

Connecticut Turnpike. The use of a yellow marginal stripe on the right side of the slow lane should be very effective when the shoulders are snow covered, as well as in rain or fog. The proven high visibility of yellow seems to have been ignored on virtually all other pikes, both for striping and for signs.

In contrast to Connecticut, the New York Thruway has been very parsimonious in its use of paint, there being no right-hand stripe of any color except on bridges and at speed-change lanes. This is inexcusable—the stripe is a necessity in bad weather or when fighting headlights. Florida’s turnpike has made the same error.

Connecticut’s answer to the headlight-glare problem is a superb example of highway lighting—the longest continuous stretch of expressway illumination ever installed.

Could These Ideas Waken Drowsy Drivers?



Sleeper horns. Every few miles in open country install in the center island a "foghorn" that would sound at frequent intervals. Emitting a deep bay—or perhaps a more musical note—the signal would impinge on the wandering minds of drivers within range and bring them back to earth.

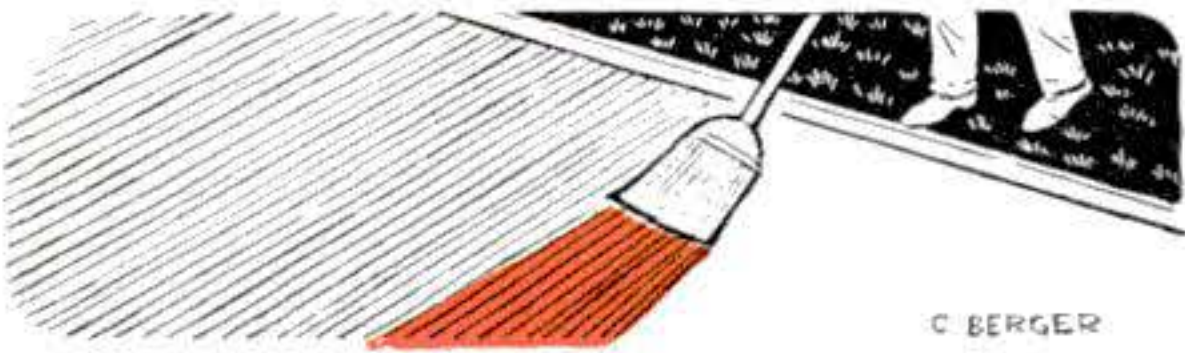

Singing pavement. It has long been customary, on steep grades, to draw a stiff broom across the fresh concrete before it has set to roughen the surface for better traction. An incidental by-product is a marked change of tire tone when wheels strike this stretch. Doing this to a 100-foot strip of pavement at intervals of every 25 miles would provide a built-in "alerter" in the highway itself.



Car clock alarm. Perhaps a car clock could be made to sound an audible alarm—a brief but imperative note at a rather exciting pitch at intervals of about 15 to 20 minutes.



Emergency warning mats. It is difficult to slow or stop some fast-moving drivers once they get the bit in their teeth—they even run through lighted flares to ram into stalled vehicles. For temporary turnouts around disabled vehicles or maintenance jobs, some form of thin, steel chain mat might be designed that could be spread across the driving lanes about a mile ahead of the obstruction. This should be rugged enough to alert the driver to the situation, but not rough enough to scare him.

"A drowsy driver is at least

lar criticisms can be leveled at a number of other turnpikes.

3 Unwise no-stopping rules in the stretches

Many of the pikes have regulations against stopping, even off the pavement, for anything but emergencies. The New York Thruway posts **NO STOPPING EXCEPT FOR REPAIRS**—which is carrying theory beyond realism on a road where it is 65 miles between some service areas.

The theory, of course, is that any car that stops on a high-speed road becomes a potential accident, which is correct. But in practice, sleepy drivers cause five times as many fatal accidents as cars standing still, or cars coming onto the road.

Last year, the Ohio Turnpike (which is posted **NO STOPPING EXCEPT FOR EMERGENCIES**) took the intelligent step of decreeing that drowsiness is an emergency, and that sleepers who are well off the highway should not be disturbed by troopers. From the very beginning the Pennsylvania Turnpike has encouraged the drowsy driver to pull off and nap, and has provided ample space for him to do so safely. Indeed, its Dawn Patrol is alert for "weavers" and *compels* them to pull off and rest.

The Garden State Parkway also has numerous roadside resting places, pull-outs and picnic areas, and encourages drowsy drivers to use them. These are busy expressways, yet none has had any unfortunate experiences due to drivers coming back on the highway after a pause.

No practical number of turnout areas can take the place, however, of adequate parking space beyond the shoulder. A driver cannot schedule his sleepiness on a map. Hence the vital thing is not only to get him off the road before it is too late, but also to make it easy for him to do so. Sleeping in a car on the shoulder is a passive form of suicide.

4 Insufficient diverting barriers or guard rails

Collision with fixed obstructions still takes too many lives. Turnpikes have many overpasses—over 500 on the main New York Thruway alone, or better than

partly a product of shortcomings in highway design"

one per mile. This bridging of local traffic over the expressway is a major factor in the toll roads' unprecedented safety record. But it is also a source of grief.

The trouble is the drowsy driver who dozes off and smashes into a bridge abutment. This happened so often on Connecticut's Merritt Parkway that guard rails had to be installed to deflect cars away from the stubborn concrete. The New York Thruway did the same thing last year over its full length; the Kansas Turnpike has them on culverts and other fixed obstructions, but not on bridge piers—yet. Sooner or later this will be a standard protective feature on all high-speed roads.

The sleepy-driver problem has all the turnpike officials by the ears. Oklahoma's 70-m.p.h. Turner Turnpike is only 88 miles long. Yet out of a total of 25 fatal accidents in 55 months of operation, 12 were due to Driver Asleep—or four times the number due to Excessive Speed, second on the list. And of a total of 32 deaths, 15 were charged to sleeping.

The Ohio Turnpike has charged 50 percent of its fatalities to this cause. The West Virginia Turnpike has announced its intention to prosecute such offenders for "driving out of control." Troopers from the Garden State Parkway have gone into hospitals to serve summonses on drivers who fell asleep and were injured in the resulting accident. Coupled with this is the experience of the New Jersey, Pennsylvania and other pikes that as many as 50 percent of their smashups, even in broad daylight, are due to rear-end collisions, compared to less than eight percent for this type of accident on rural roads in general. One obvious factor is "highway hypnosis," which amounts to being asleep with your eyes open.

The pikes have a relatively high ratio of single-car accidents. On rural roads as a whole, the single-car mishap represents only about a third of the non-pedestrian accidents. But on the Oklahoma Turnpike it accounts for 67 percent; on the Ohio, 72 percent; on the Kansas, 77 percent. All of which is pretty hard to explain on superhighways devoid of the sharp curves, steep grades and other inherent physical hazards of most public roads.

5 The boredom that kills

The drowsy driver, or the "hypnotized" one, is at least partly a product of faulty highway design. And of the 15 turnpikes that I've driven, the only one to make an aggressive attack on the problem is the Garden State Parkway. The approach has been threefold. One feature is the "singing shoulder." This is a heavily corrugated strip of concrete, about a foot wide, marking the right-hand margin of the right-hand driving lane. If your wheels wander over on that strip, the resulting tire howl jerks you out of your doldrums. I saw three letters from motorists who say this device saved them when they dozed off. Lately the New Jersey Turnpike has adopted the same expedient at exit and access lanes.

The Parkway's second approach is "fluid contour"—purposely providing gentle curves to keep the driver driving all the time. The longest straight stretch is 3½ miles on the New Jersey Turnpike, two miles on the Indiana Toll Road, but there is no straightaway longer than *one* mile on the Garden State Parkway. In contrast, I clocked nine to 12 miles between curves on the Oklahoma and Kansas turnpikes.

The third thrust at boredom is an abundance of planting and landscaping. No less than \$5,000,000 was included in

[Continued on page 198]



SINGING SHOULDERS of the Garden State Parkway cause tires to howl if a drowsy driver wanders over onto the right-hand shoulder.

Twin Reactors to Drive World's Biggest Sub



HOW THEY COMPARE:

TRITON

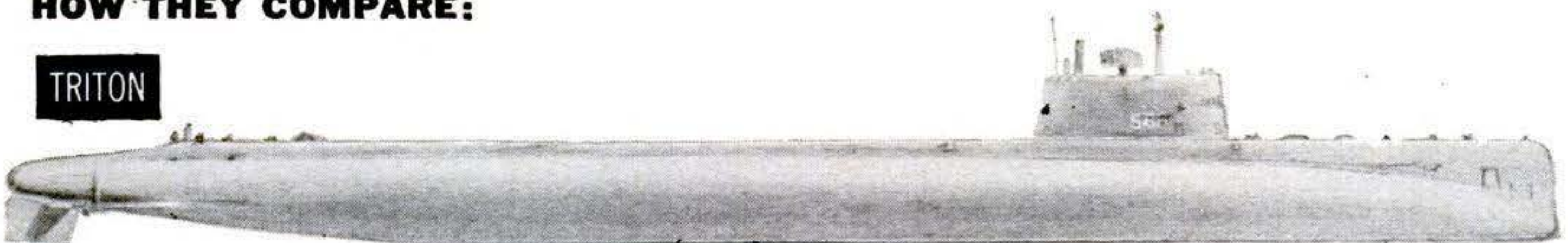

POWER: TWIN NUCLEAR REACTORS LENGTH: OVER 400 FEET DISPLACEMENT: 5,450 TONS CREW COMPLEMENT: 110

NAUTILUS

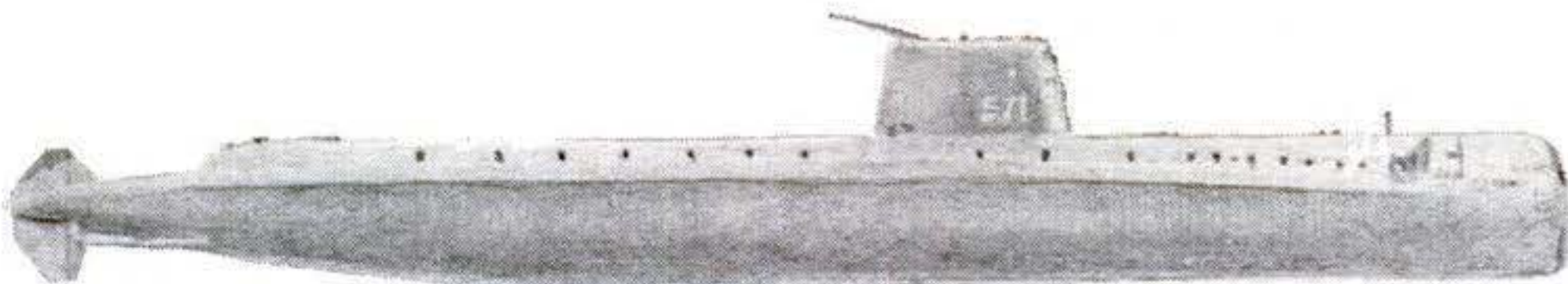

POWER: SINGLE NUCLEAR REACTOR LENGTH: 319 FEET DISPLACEMENT: 2,980 TONS CREW COMPLEMENT: 101

ALBACORE

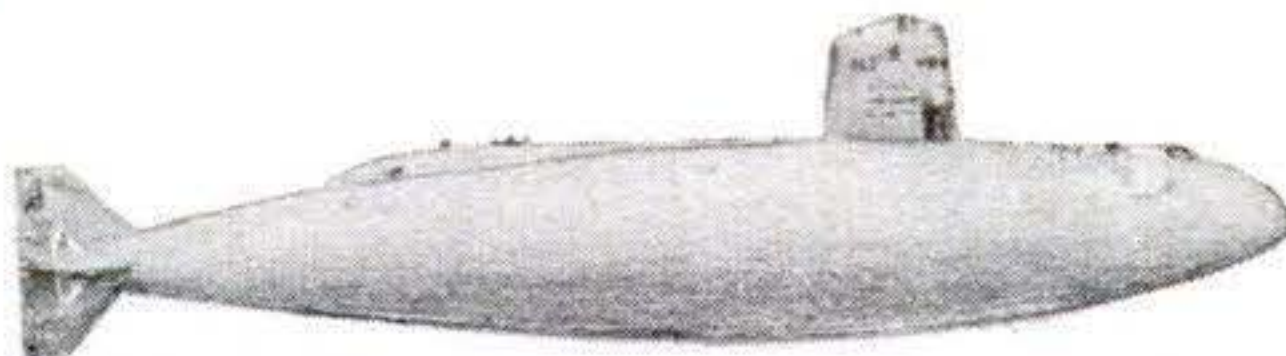

POWER: DIESEL-ELECTRIC LENGTH: 200 FEET DISPLACEMENT: 1,800 TONS CREW COMPLEMENT: 40

Bow as sharp as a destroyer's, Triton will be the first of a new class of high-speed attack subs to slide into the water

By Eliot Tozer

SOMETIME this summer a submarine named Triton will groan down the ways at Groton, Conn., and slide into the murky Thames River. She'll make a big splash in more ways than one. For Triton is the biggest, toughest and most powerful submarine ever built.

Early this spring, I was allowed to prowl through the yard of the Electric Boat Division of General Dynamics Corp. where three of the Navy's top-priority A subs are being built. My guide, a hard-bitten New England shipbuilder, had greeted me coldly. "I'll show you Triton," he said, "but you'll look only where you're told and you'll not mention my name."

When I agreed, he wrestled his bulky frame into a faded mackinaw and stalked out the door.

Everyone spoke to him as we hurried down the steep hill to the water, but he only nodded. We climbed the scaffolding that clung to Triton's armor-plate sides and he waited impatiently while I teetered out onto her destroyer-sharp bow and looked aft.

From where I stood, the Triton stretched more than 400 feet—probably 100 feet or so longer than the former record breaker, Nautilus.

"She's almost as big as a destroyer," he said, warming a little, "but she can fly underwater like the Albacore." He was referring to the Navy's blimp-shaped sub that is "flown" with a control stick like an airplane's. Prototype of a new class of high-speed attack subs, the 1,800-ton Albacore "banks" at 30 degrees and dives for her underwater "floor" like a jet plane.

The Triton is just as maneuverable, yet

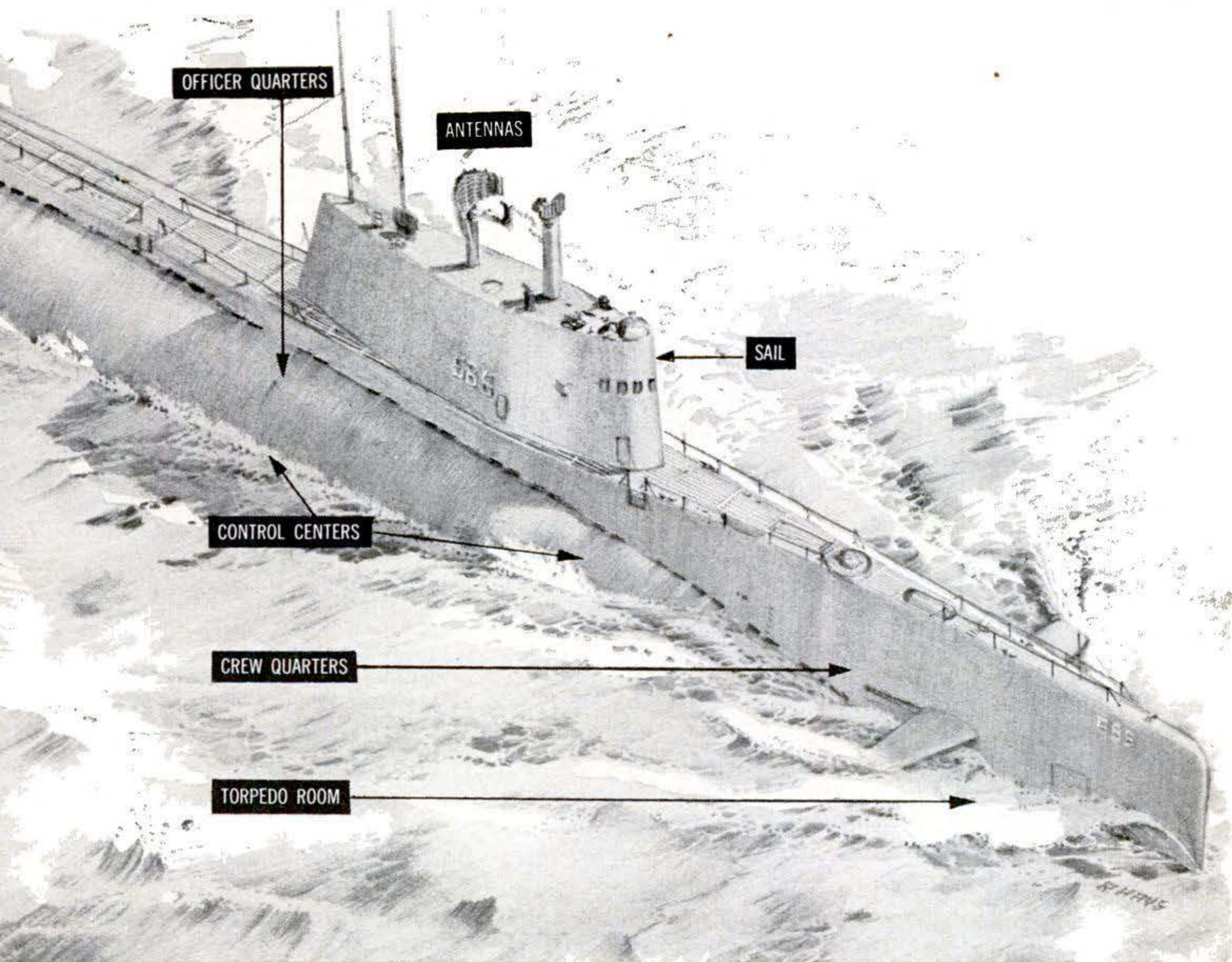

She'd churn across the top of the world under polar ice to

she displaces a whopping 5,450 tons.

"What was the biggest sub before?" I asked.

"The French held the record with the *Surcouf*," he said. "It displaced 4,304 tons. The second largest was the *Argonaut*, a U. S. minelayer displacing 4,080 tons. But they were built in the twenties. To see how unusual *Triton* is, you have to compare her to our newest nuclear sub, the *Skate*. *Skate* weighs in at 2,190."

Cautiously, we edged our way along *Triton's* narrow deck to the gaping hole for the "sail" (formerly conning tower). I peered down the blue haze of welding smoke. Her bilge, lost in shadow, was almost 40 feet below us. "From her keel to the top of her sail she'll rise over 70 feet," he said.

"What does it take to drive a ship this size?" I asked.

"Follow me," he grunted and started toward the stern.

WE STOPPED and he leaned down to pull back the corner of a huge tarpaulin. Through another gaping hole I looked down and saw the huge container for the *Triton's* nuclear reactor.

My guide nudged me and pointed to another container farther aft. "Not one reactor," he said, "but two." *Triton* is the first twin-reactor sub in the world. Her engines probably pull twice the horsepower of the *Nautilus*. She's so powerful she can outrun the *Nautilus* with ease.

I did some fast figuring. I knew that the Navy has never officially admitted to a top speed of more than 20 knots for the *Nautilus*, but her log shows she once cruised from Key West, Fla., to New London, Conn., at "an average speed of 20 knots." A top speed of 30 knots would not be unreasonable then. Could the giant *Triton* race underwater at 40 knots?

"*Triton's* range is secret," said the engineer, "but I can tell you that her advanced-design reactors will drive her a lot farther than the 72,000 miles that *Nautilus* went on her first nuclear core."

We climbed down a wooden ladder into officers' country where the clang of hammer against steel and the machine-gun clatter of chipping guns jabbed painfully at my eardrums. My escort yelled above it, "You'd never know it now, but this

will be the most livable ship in the Navy. We've done everything possible—and some things that were impossible—to make the crew happy."

His pride in *Triton* was beginning to show on his face. I grinned. "More livable than the *Nautilus*?"

HE SWEPT one arm upward. "Look at the space," he said. "She's got more decks than the *Nautilus*." I had been aboard the *Nautilus* and I knew that she had two decks, a revolutionary development in submarine construction when she was launched only four years ago. Now here was *Triton* with three.

I looked up at her high bulkheads and wide companionways and saw that, even though *Triton* was half finished, her spaciousness compared with many of the Navy's surface ships.

We inched along a catwalk and up a short ladder, emerging into a smoky chamber where the intermittent blaze of the welders' torches threw crazy shadows on the upcurving walls. "This is where she'll earn her keep," he yelled. "In this room she'll have a combat information center like the CICs on the big carriers in World War II, only *Triton* will carry as much detection gear as you'd have found in an entire task force then."

Outside on the upper deck I looked forward past the welter of workmen to the bow where *Triton* would launch her torpedoes. Just aft the torpedo room is berthing space for the crew, then come officers' country, the control center, the two reactor compartments, and, in the stern, the two engine rooms. *Triton's* interior arrangement is the same as *Skate's*, but her facilities are strung out along well over 400 feet, while *Skate's* are compressed into 257. *Nautilus*, in comparison, stretches 319 feet.

UNLIKE the missile-firing A-subs, *Triton* is a radar picket ship. Her job is to range along through the open seas ahead of her task force and find the enemy. And she's equipped to put the finger on everything—missiles, aircraft, surface ships and submarines. She'll carry several radars, a tremendous battery of communications equipment, and new super sonar—the works.

give us warning

ATOMIC TRIO: Lined up side by side on the ways at Groton, Conn., are three of the A Subs in the Navy's building program. From left: Skipjack, Skate and the massive Triton. Skipjack's whalelike hull is designed for maximum speed, while Triton's twin reactors will yield superpower and enormous range.

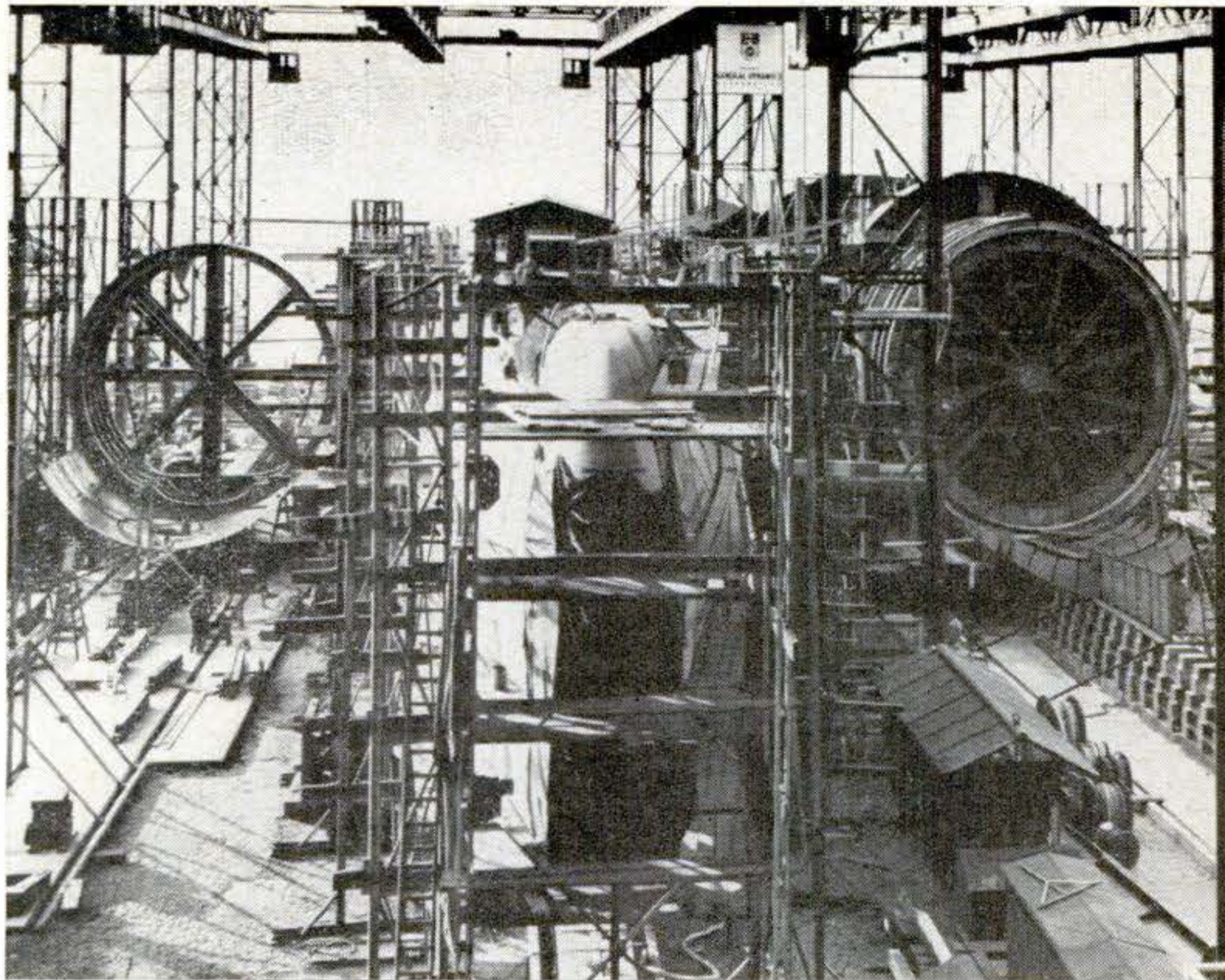

Back in the engineering office, the chill went out of his voice altogether. "Sure she's big," he said. "She has to be. Why, even without her twin reactors she'd be mammoth because she has to carry so much gear and house so many men to maintain and operate it." Normal complement will be about 110 men. Skate's is 75.

I learned from high Navy officials that there are other reasons for Triton's gigantic size. She has tremendous range: She will be able to churn across the top of the world *beneath* the polar ice on Distant Early Warning missions (she could give us much earlier warning of enemy air attack than the DEW line can); she's designed to cruise many times around the world, listening for Russian subs; and she can patrol the outer fringes of a fast-moving, widespread task force for weeks at a time, unsupported—and still, in many cases, be able to repair her own battle damage at sea.

Deep in her cavernous hold are extra coolant pumps, valves and piping. In her huge workshops are the heavy wrenches, welding equipment and pipe-fitting gear found normally only at repair stations on shore. And her extra-large crew will be swelled by men whose mission will be to keep Triton running even when she has taken near-lethal hits.

And take hits she well may. For Triton will go, as the Navy likes to say, "in harm's way." It's a dirty job, but her

mission is to roar in close to the enemy's task force, shoot to the surface, count their noses, then get off her message to the surface fleet, directing carrier-based, A-bomb jets to the target.

IF THE enemy succeeds in zeroing in and it gets too sticky, the skipper will "pull the plug" and dive for the depths. There, Triton can lie quietly beneath the cold layers of water that confound sonar. For hours, if need be, she will rock gently in the deep undersea, her turbines humming quietly but sending out no telltale trails of exhaust bubbles.

Then, her mission nearly accomplished, she will shoot once again to the surface and press forward where she can assess visually the damage our fleet has done.

At Electric Boat they call her the radar destroyer that can submerge. "She can take a lot of near-misses," they said. "She's double-hulled, the only full double-hulled nuclear one in the Navy, and she's as completely compartmentalized as a surface ship. So she can make way even when she's shipping water. Not that she'll take much water. The crew can hold it out by forcing compressed air into a damaged compartment."

"What about nuclear radiation if she's hit?" I asked.

"What we worry about is not that," they said, "but loss of cooling of the re-

[Continued on page 202]

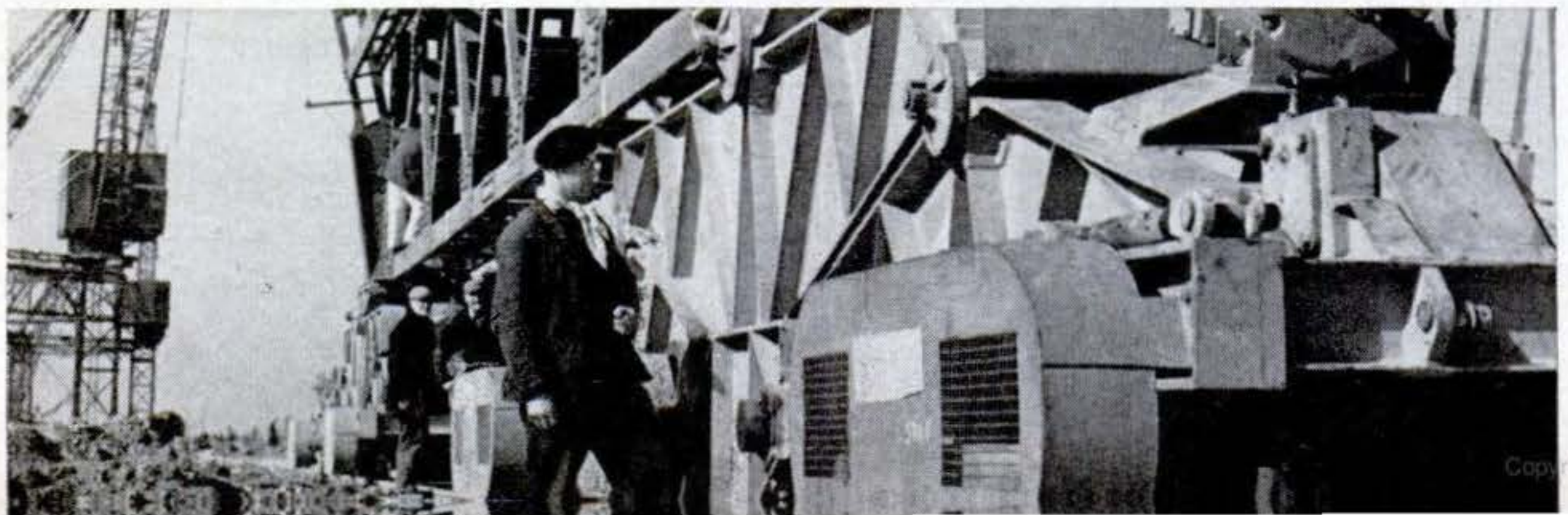
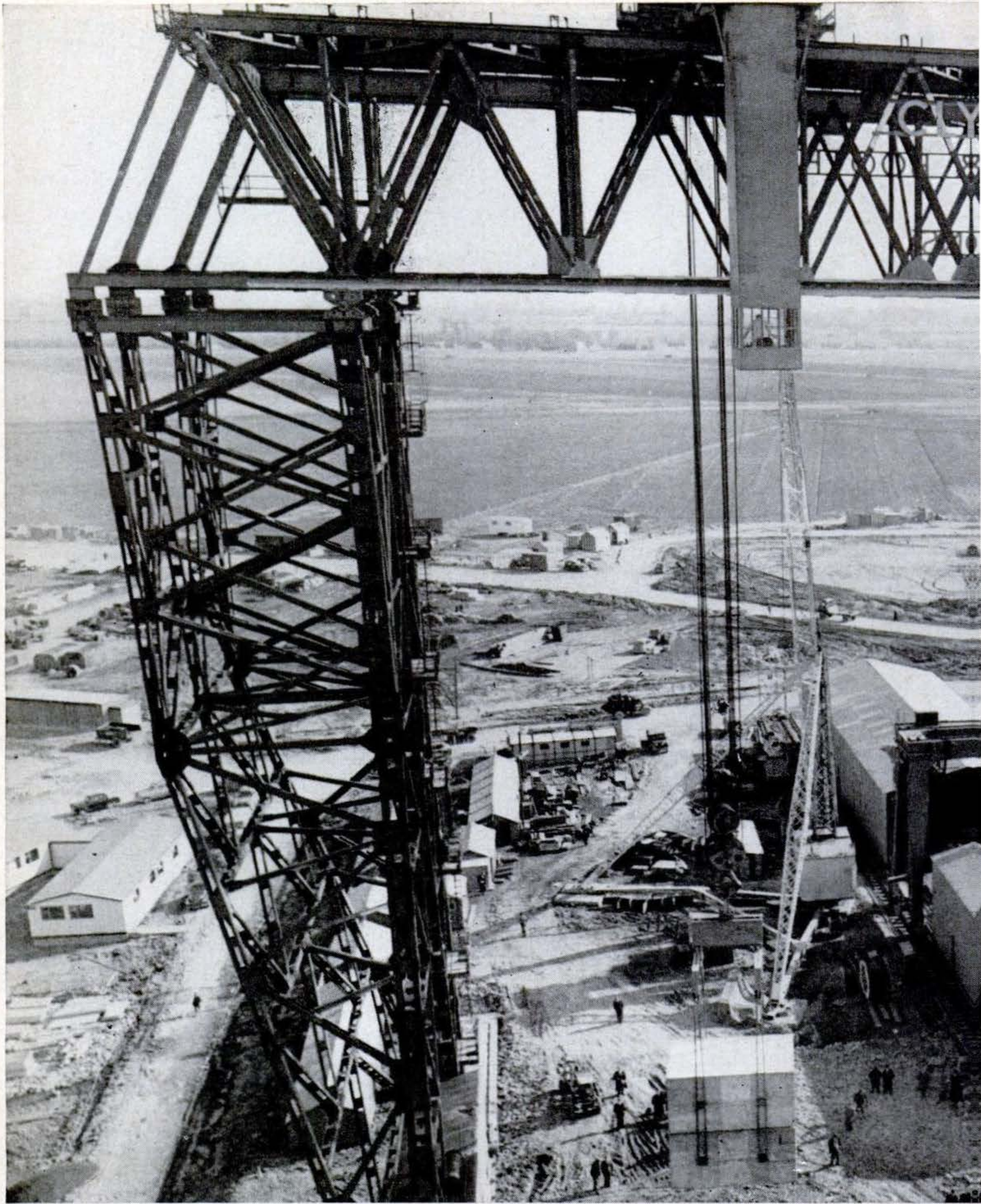

Picture News

IN THE WORLD OF SCIENCE

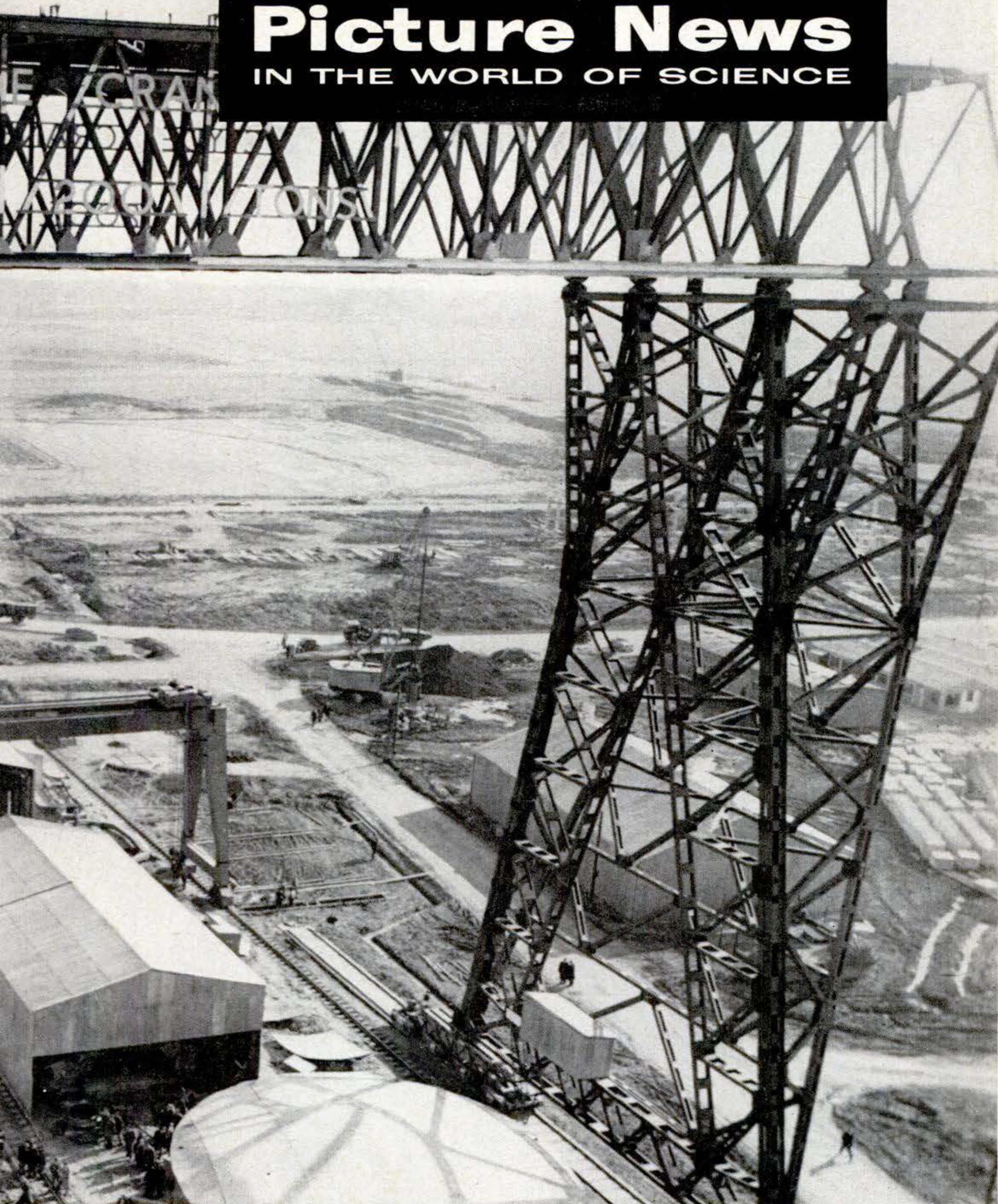

Steel colossus bestrides A-power plant. This 170-foot-tall crane straddles the Bradwell nuclear-reactor station being constructed on the Essex coast by a British power company. Appropriately named Goliath, it is shown here lifting a 200-ton block of concrete. At left is one of the four giant feet on which the mammoth crane moves on standard-gauge rails. The power station will be completed in 1960.



Collapsible scooter. This tiny motorbike is intended to give pilots of small planes personal ground transportation to and from airfields. Its four parts can be stored easily in the plane during flight and assembled at the airport with three wing nuts. It has a double seat and telescopic suspension on both wheels.

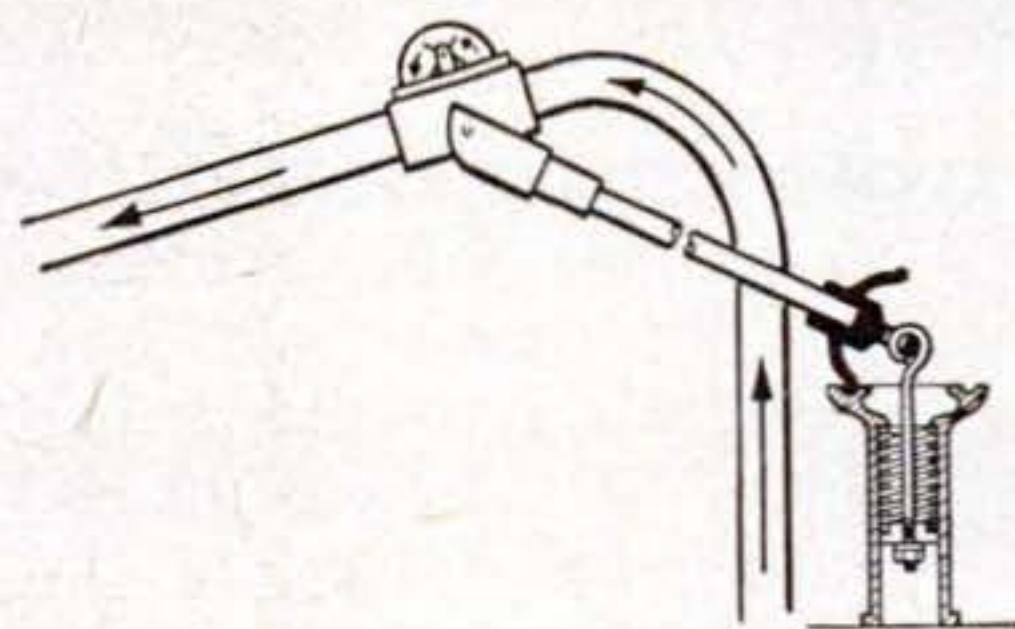

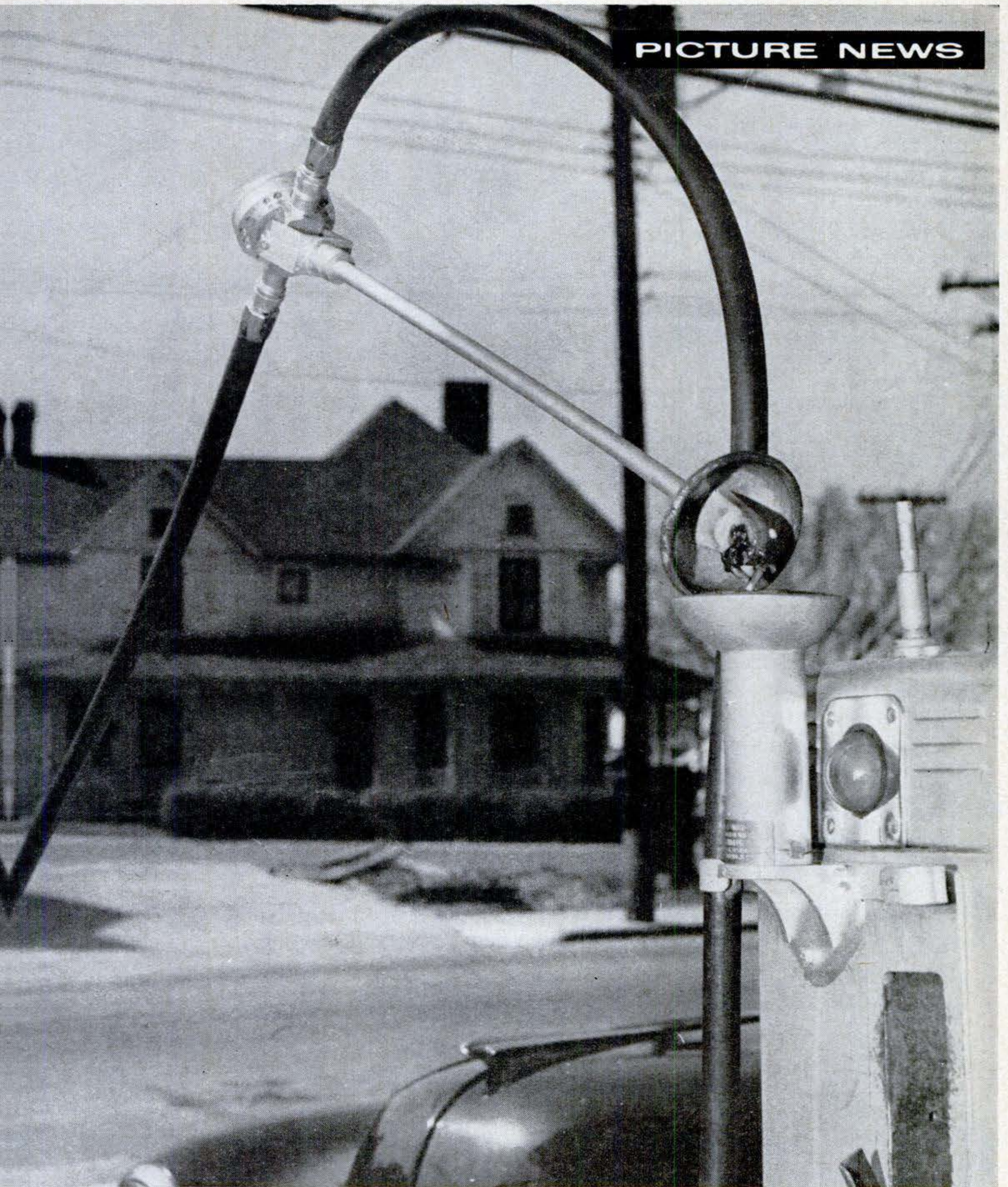

Spring-back gas hose can't smear cars. This spring-balanced attachment bolts to an ordinary gasoline pump and retrieves the hose without letting its nozzle drag in dirt and grease. W. H. Vestal of Greensboro, N. C., designed it. The hose-carrying stanchion works like an old-fashioned roly-poly doll—but instead of a counterweight, a heavy spring in its base (drawing at left) brings it back erect when pressure on the 15-foot hose is released. Extending from the top of the pump, it can refuel a car standing away from it in any direction.

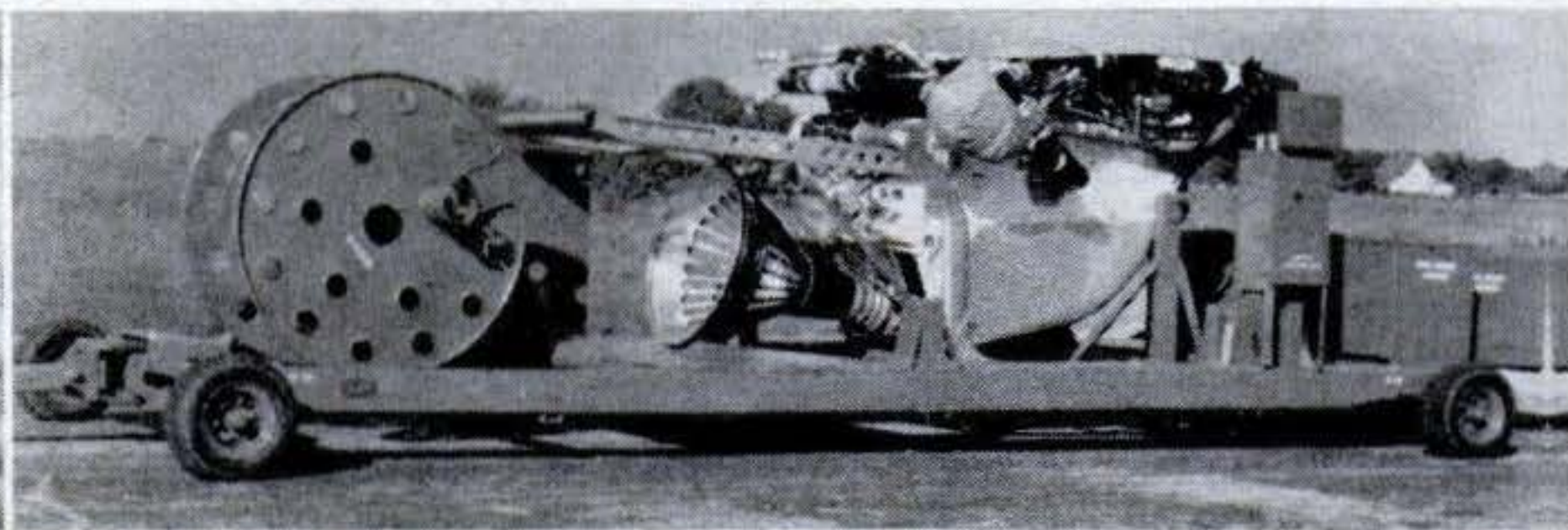
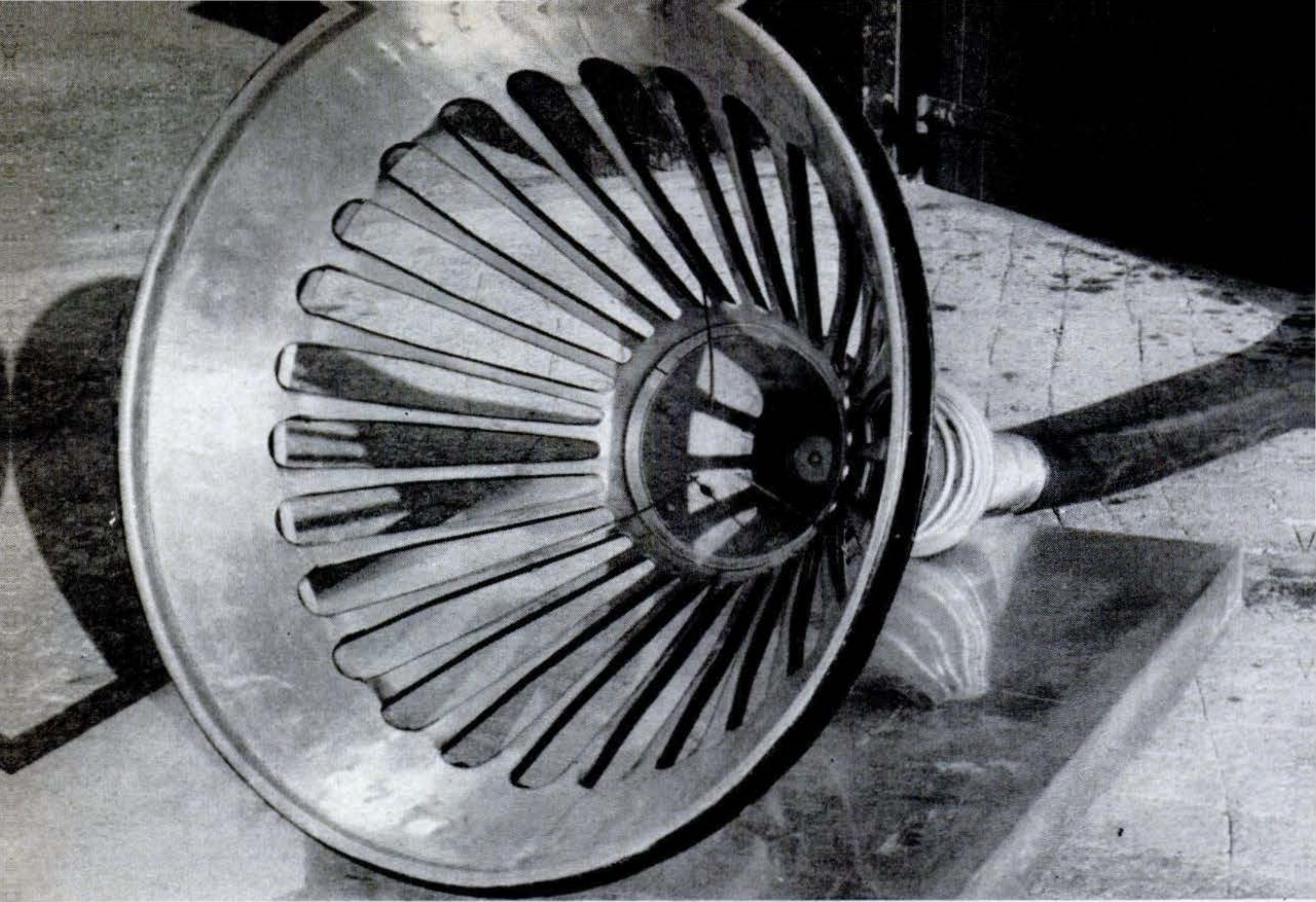

Clip-on refueling package. With this unit (above, right) tucked in its bomb bay, any bomber becomes a tanker capable of refueling jet fighters in flight. British-built, it consists of tank cells, turbine pumps and a 90-foot reeled hose complete with drogue and conical coupling (top photo) illuminated for night refueling. It is used also by U.S. Navy planes.

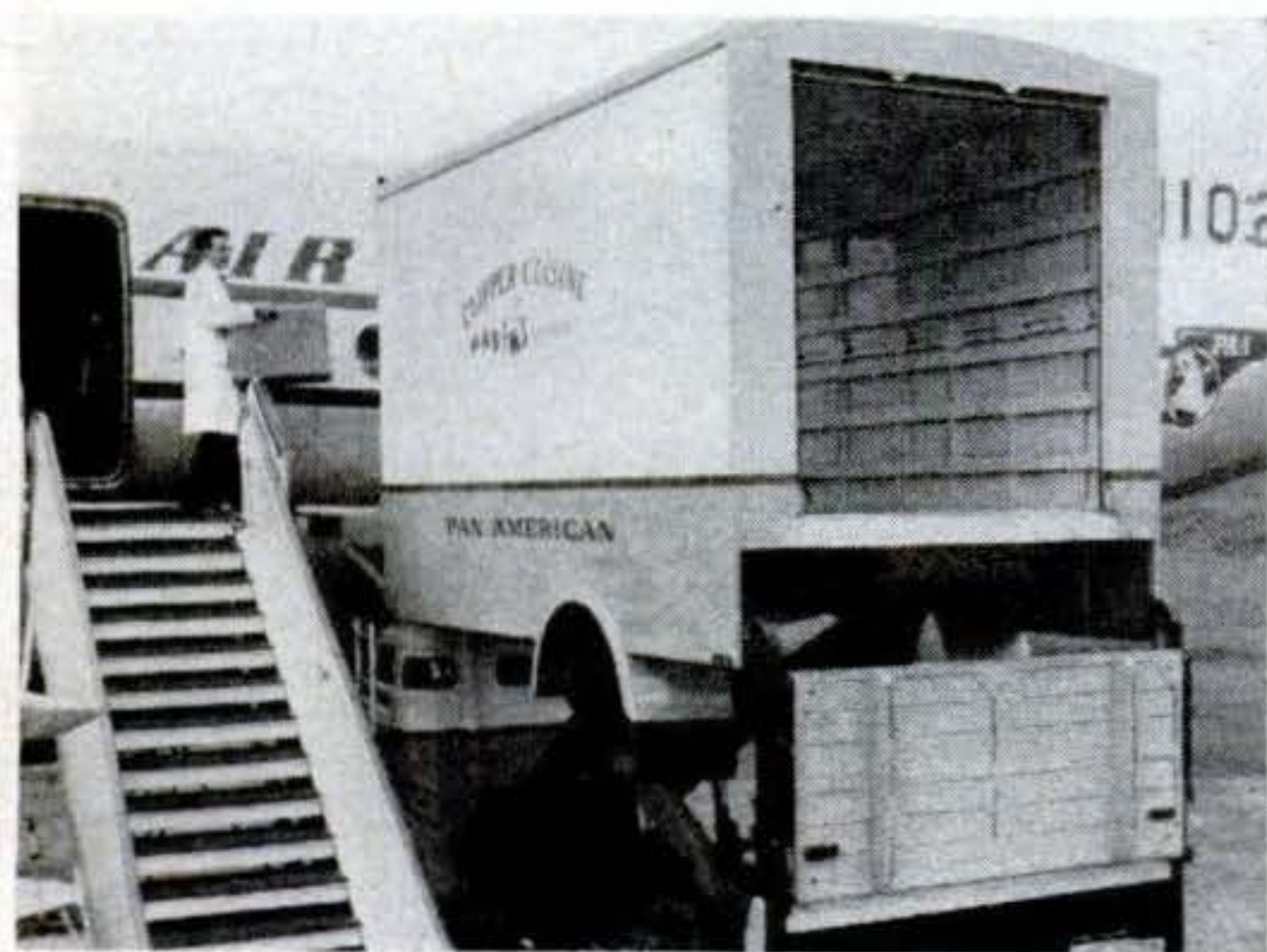

Elevator truck. This five-ton lift truck can hoist its body up to 13 feet to line up with the loading bay of any aircraft in the world.

It has an auxiliary flip-up sidepiece that acts as a bridge to reach the head of the passenger stairway at left and a power-operated tailboard that alone will raise up to a ton of cargo.

A rubber bumper on a front bridge turns on a warning light inside the cab if the truck touches the plane fuselage. The truck loads from the back, unloads from the front above the driver's head.

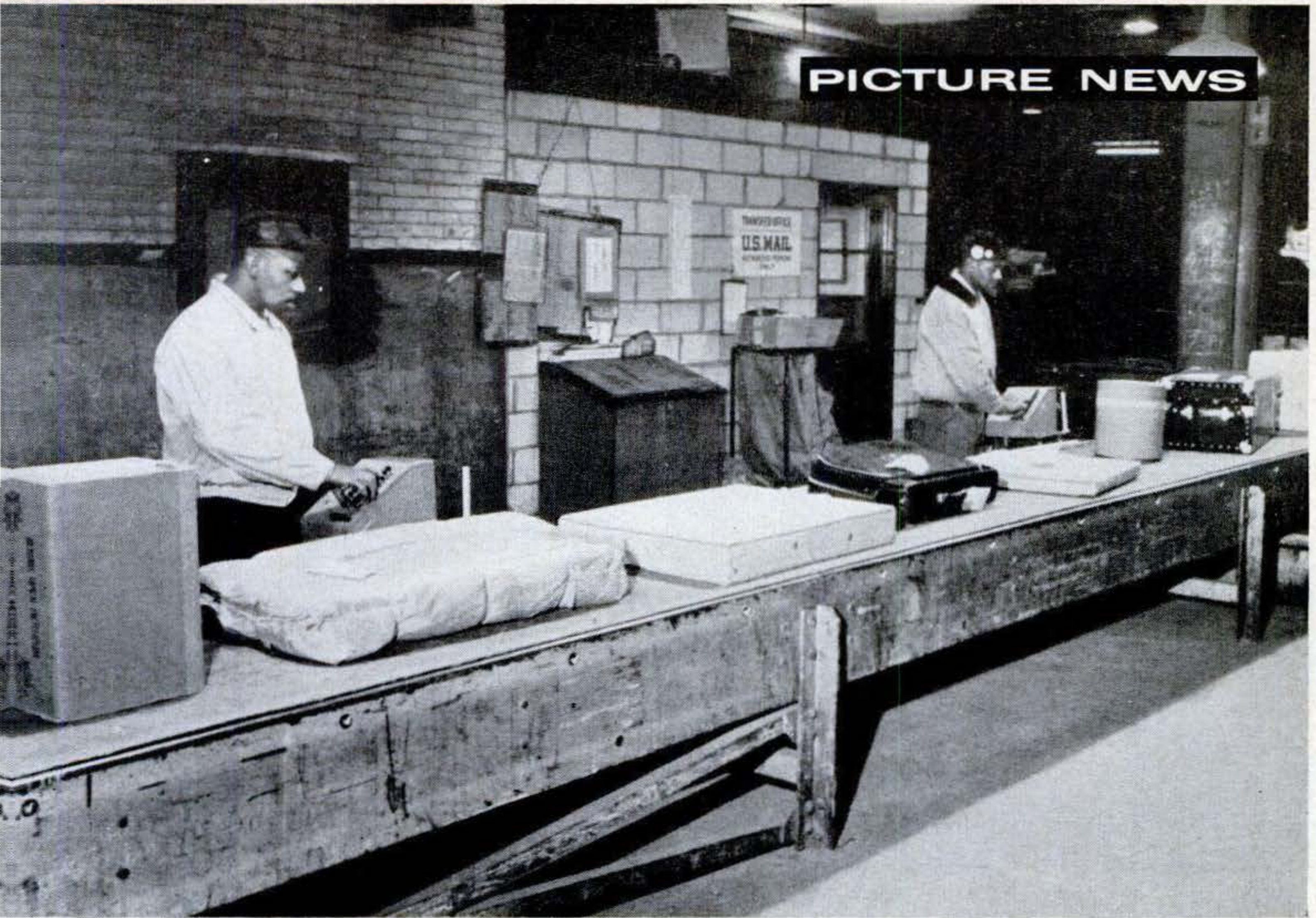

Speedway for parcel post. Packages now get on trains faster thanks to electronic brains. Here's how a Stewart-Warner system works at Pennsylvania Railroad's station in Philadelphia.

Packages too big for sacks are placed address up on a conveyor and their destinations punched (top) into an electronic memory. An electric eye (right) records time as they pass. The brain then reads the destination code and pushes them by chain-and-sprocket paddles (bottom) off the main belt to rollers that take them to any of 39 different trains.

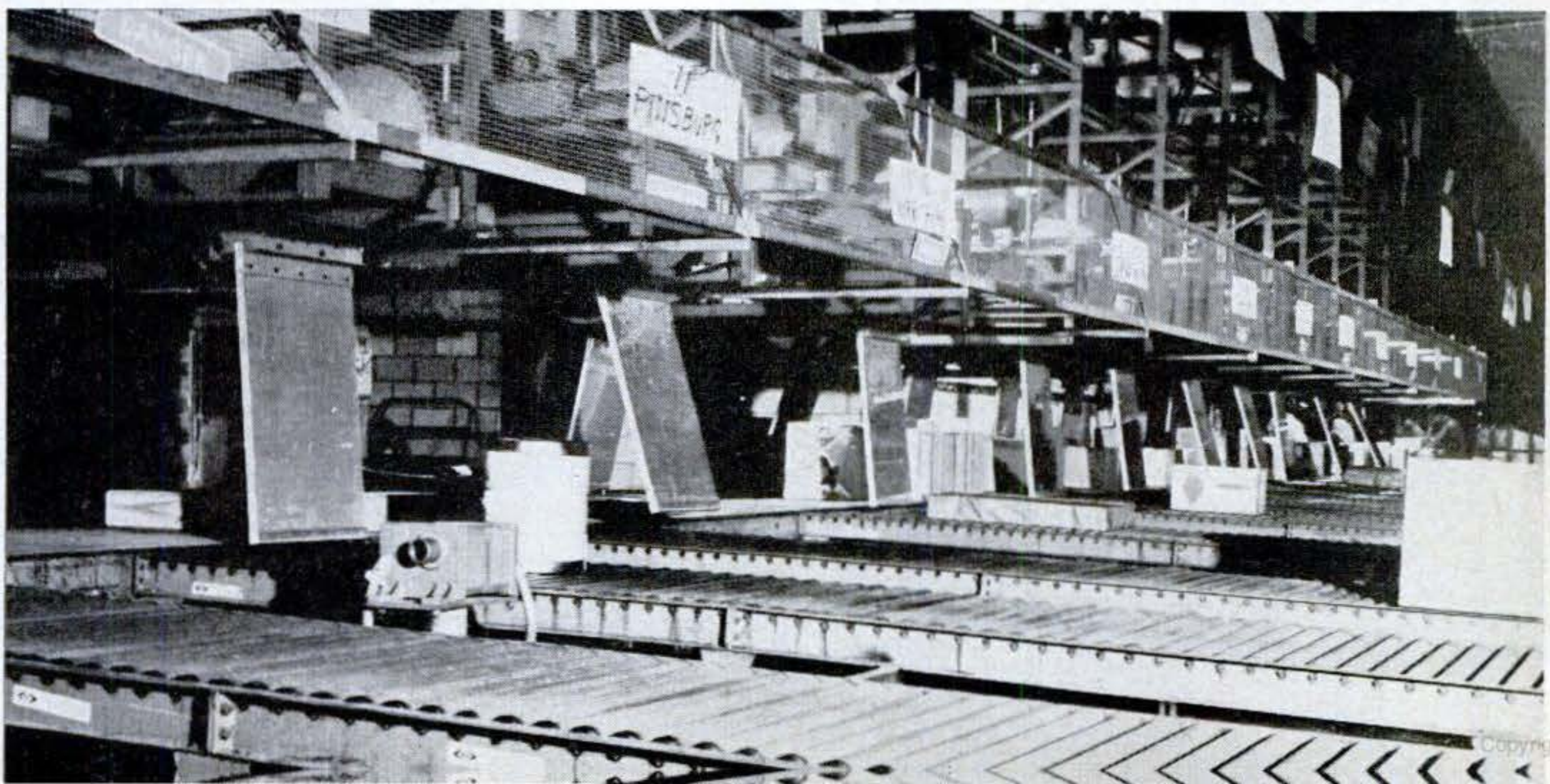
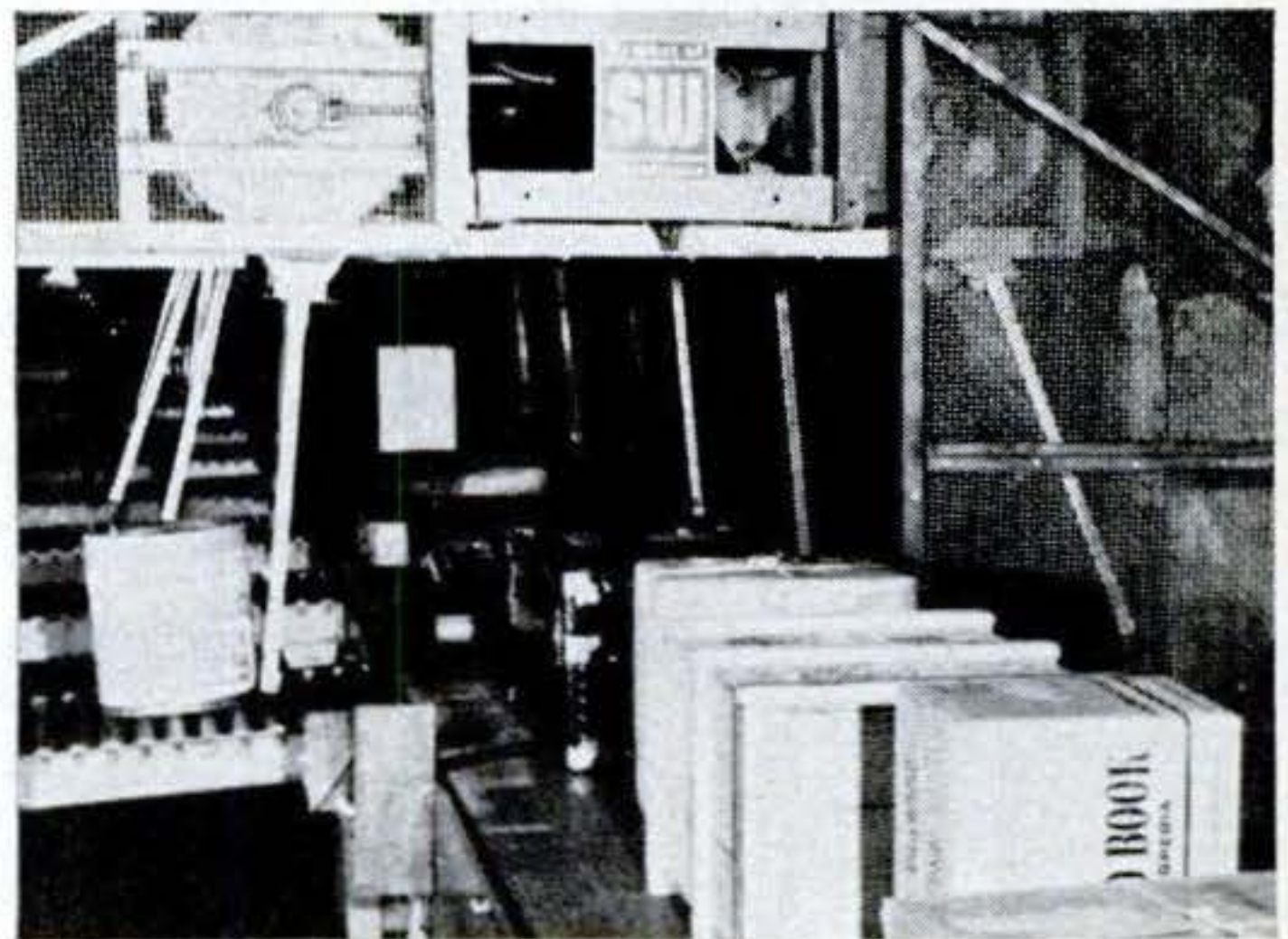

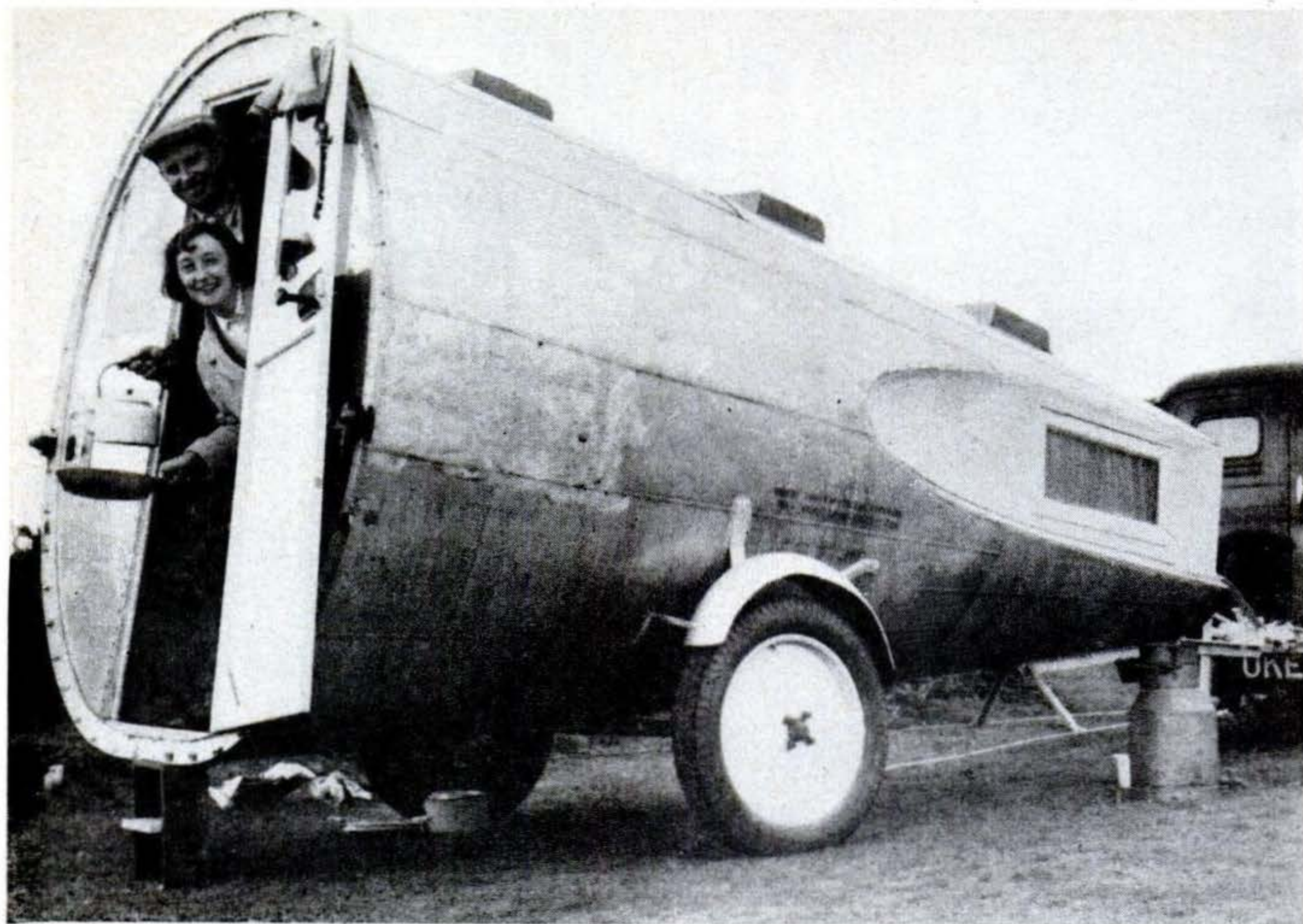

Plane's tail now a trailer. When a Dakota transport came to grief at Croydon Airport, farmer Claude Jesset of Hadlow Downs, Sussex, latched on to the tail section for \$50. For \$40 more he converted it into a trailer. It's wired for lights, has a built-in bed, kitchen and dinette.

Circular camera takes cone-shaped photo. The 200-degree panorama below of Rockefeller Plaza, New York, was snapped by the camera at far right. It runs by gears and a spring-wound motor, works by rotation and scanning, and takes pictures with an f/4.5 lens on four-

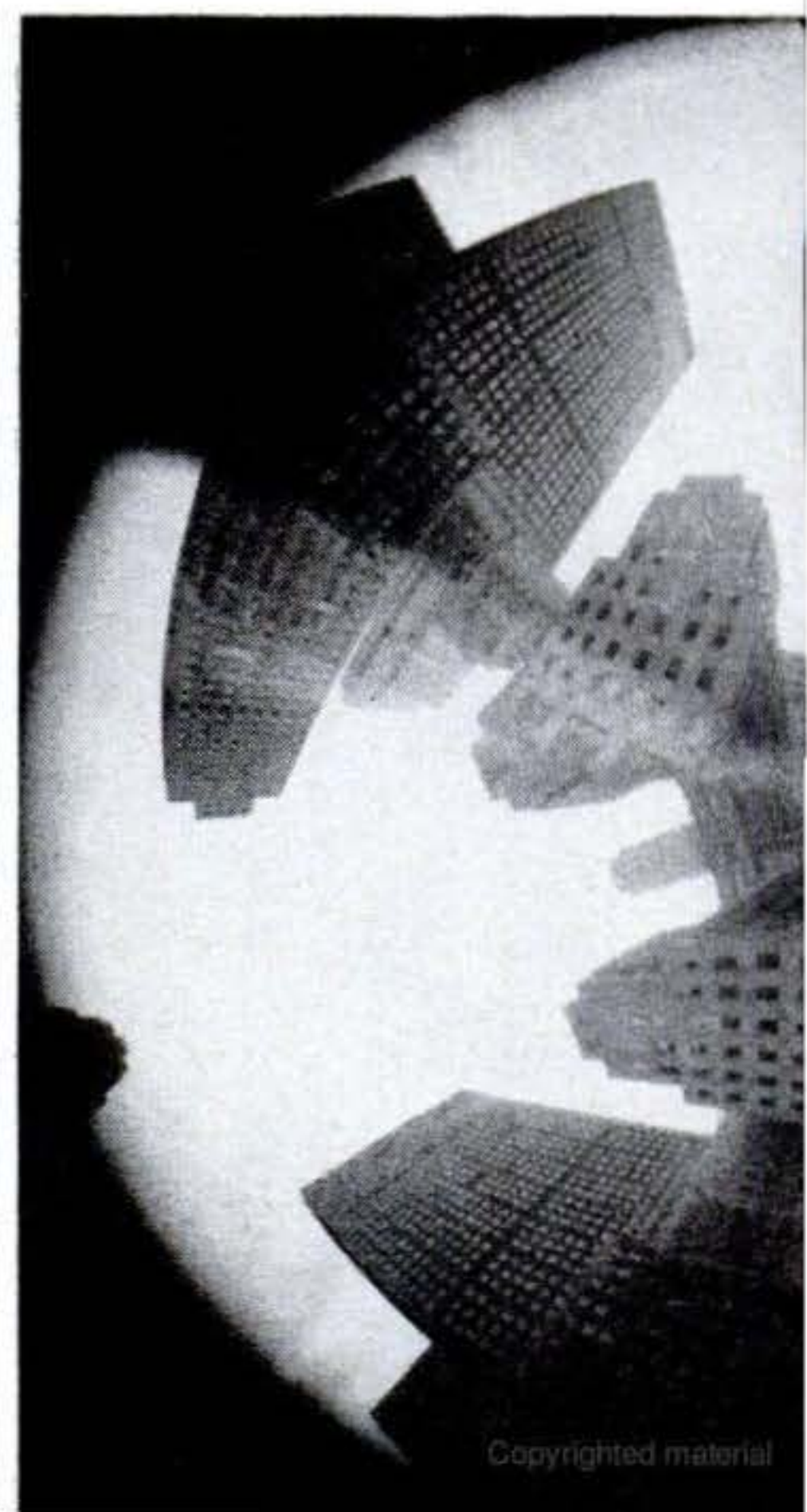
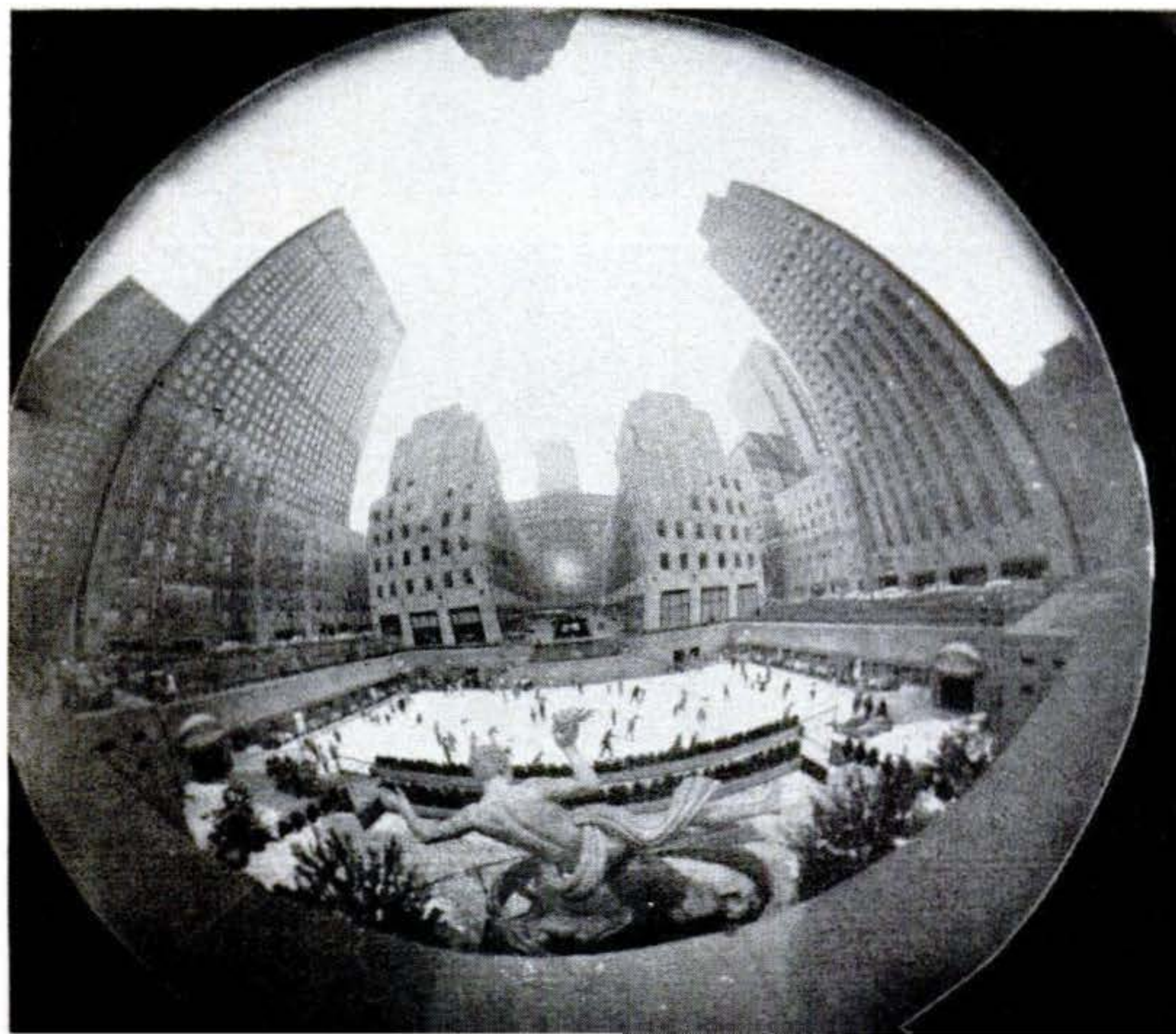

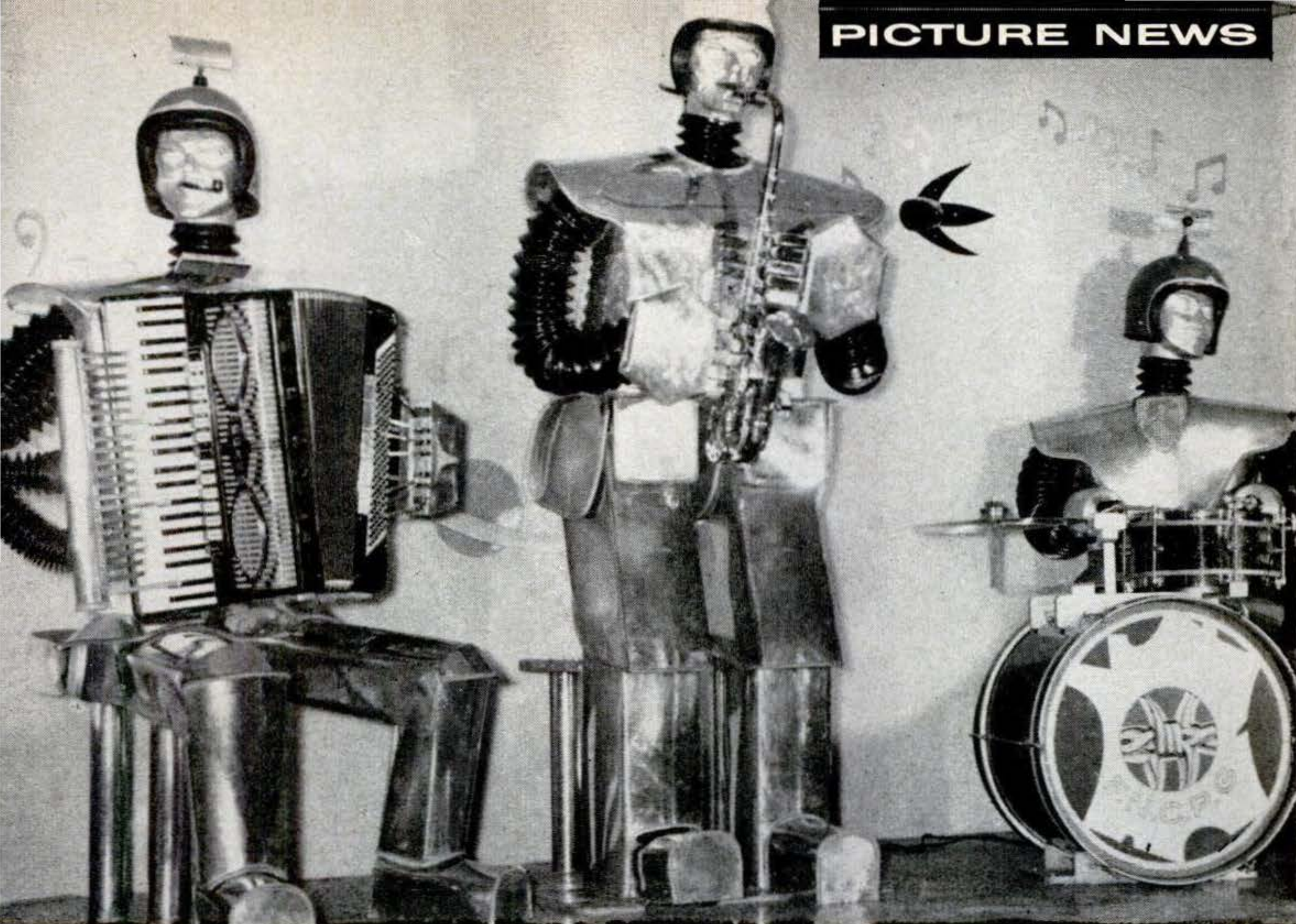

Robot dance band. These Martian-looking cool cats swing, not by ear, but by electronic tape. They are the latest rock-and-roll fad at a popular Paris night club. Instruments are the real thing. Drums are beaten, the accordion fingered and squeezed, compressed air blown in the sax.

by-five film. Flat prints (center) show partial duplication that is overlapped when they are cut on a radius and formed into a cone. Dr. Eugene Trachtman, Red Bank, N. J., inventor, visualizes astral and plane-mapping use. One of his views is displayed at the Brussels Fair.





Traveling mailbox. Letter boxes are attached to buses making the regular routes in Naples and other large Italian cities in a scheme to speed up mail deliveries. Here a tourist posts a letter in a box that will be emptied within the hour at the central post office which all buses are scheduled to pass. The legend "servizio celere" painted on the box means "fast service." And that's what the Italians get.

Traveling wind tunnel. Instead of building an expensive wind tunnel to test models of new planes at its Canadian plant, De Havilland mounts them on top of a flying test bed. Results are the same: model performance under the desired wind velocities. Below, a model of the Caribou, De Havilland's new twin-engine utility plane, rides piggyback on an Otter.





Classroom to schoolyard to water. Safety in handling boats is taught to teen-age youngsters as an optional course—first of its kind in the country—at Terry Parker High School in Jacksonville, Fla. At top, Principal Sidney Friend gives instructions in theory to his water-safety class; center, enthusiastic students get a close-up view of the school's outboard runabout; bottom, a group practices on the St. Johns River.

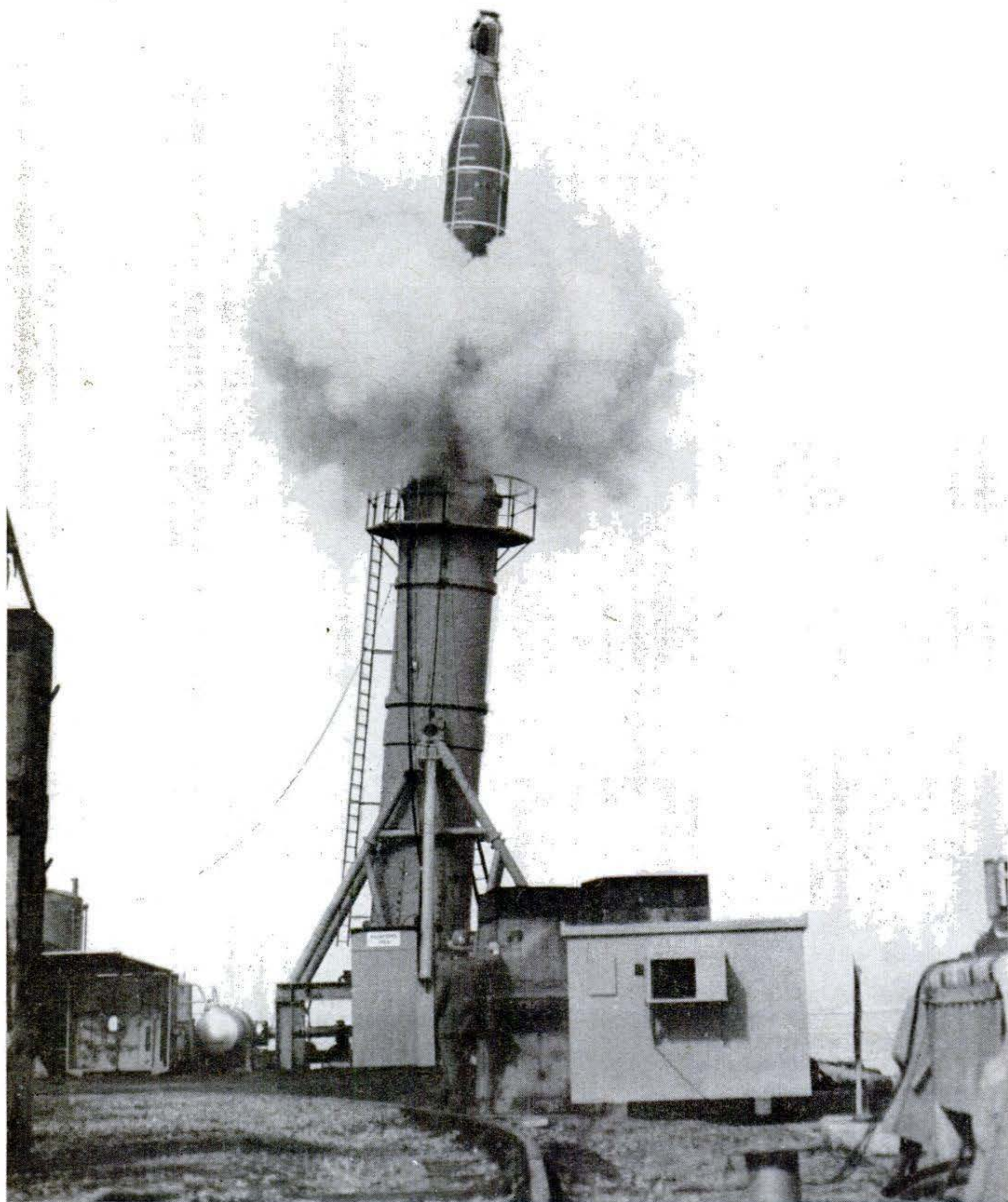

Life-jacketed Polaris. This dummy missile simulating the Navy Polaris reports via electric cable (left) on its own launching before falling into San Francisco Bay. There a tethered life preserver on its nose floats free to mark the spot, and a giant crane recovers the dummy for another test. Subs will launch the real Polaris from underwater.

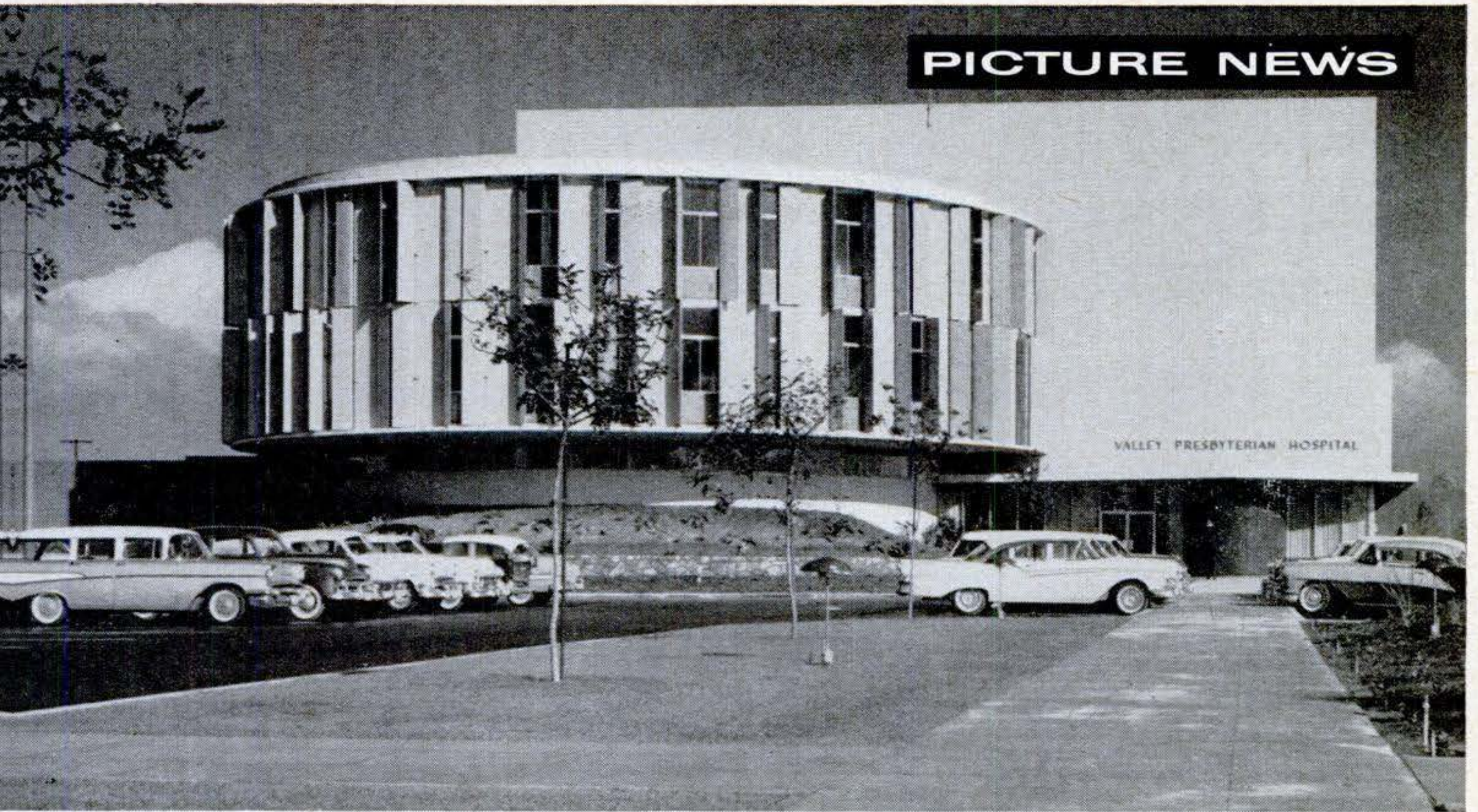

Circular hospital helps nurses get around. Hub-and-wheel floors reduce walking time of nurses at the 63-room Valley Presbyterian Hospital at Van Nuys, Cal. Instead of facing dead-end line corridors, attendants pass directly through nurse stations to the patients' rooms. Pereira & Luckman of Los Angeles and New York were the architects.

Telescoping gangplank. A new covered ramp to keep passengers dry in wet-weather boarding is now in service at Chicago's O'Hare Airport.

It extends in three sections from 55 to 107 feet and rotates at the terminal entrance in a 120-degree arc to fit snugly against the loading door of an airliner.

Its free-swinging end is carried by a power-driven dolly that supports its weight, moves it into line with the plane and adjusts its height by means of hydraulic cylinders. Inflated rubber pads cushion contact with the fuselage.

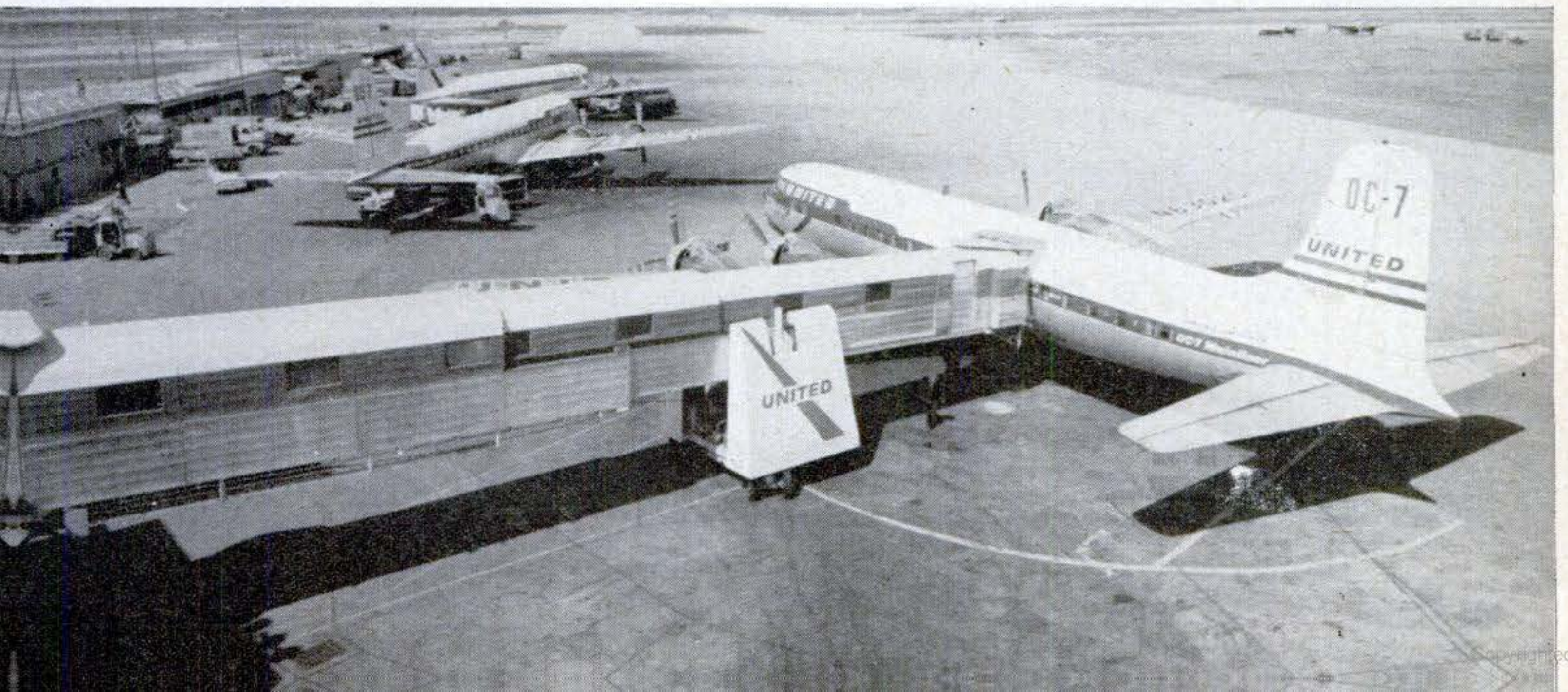

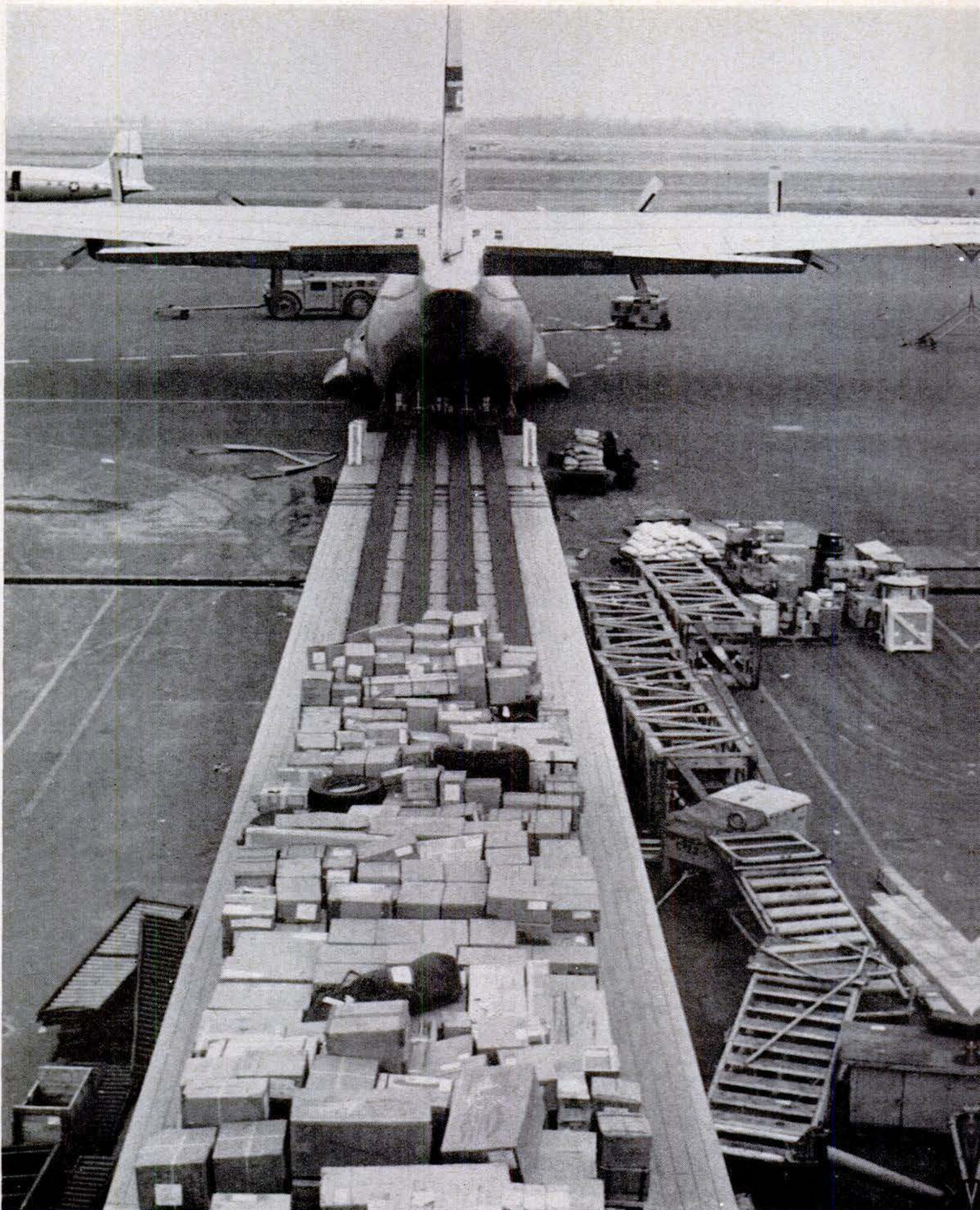

Speed-loading a cargo giant. At a special loading dock at its home base (Dover Air Force Base in Delaware), this big C-133 carrier takes on between 50,000 and 100,000 pounds of high-priority NATO supplies for Europe. Cargo is piled on pallets which are pushed onto rollers set in the ramp, and speeded into the C-133's cavernous maw. Loading can be completed in 10 minutes with the conveyor ramp.

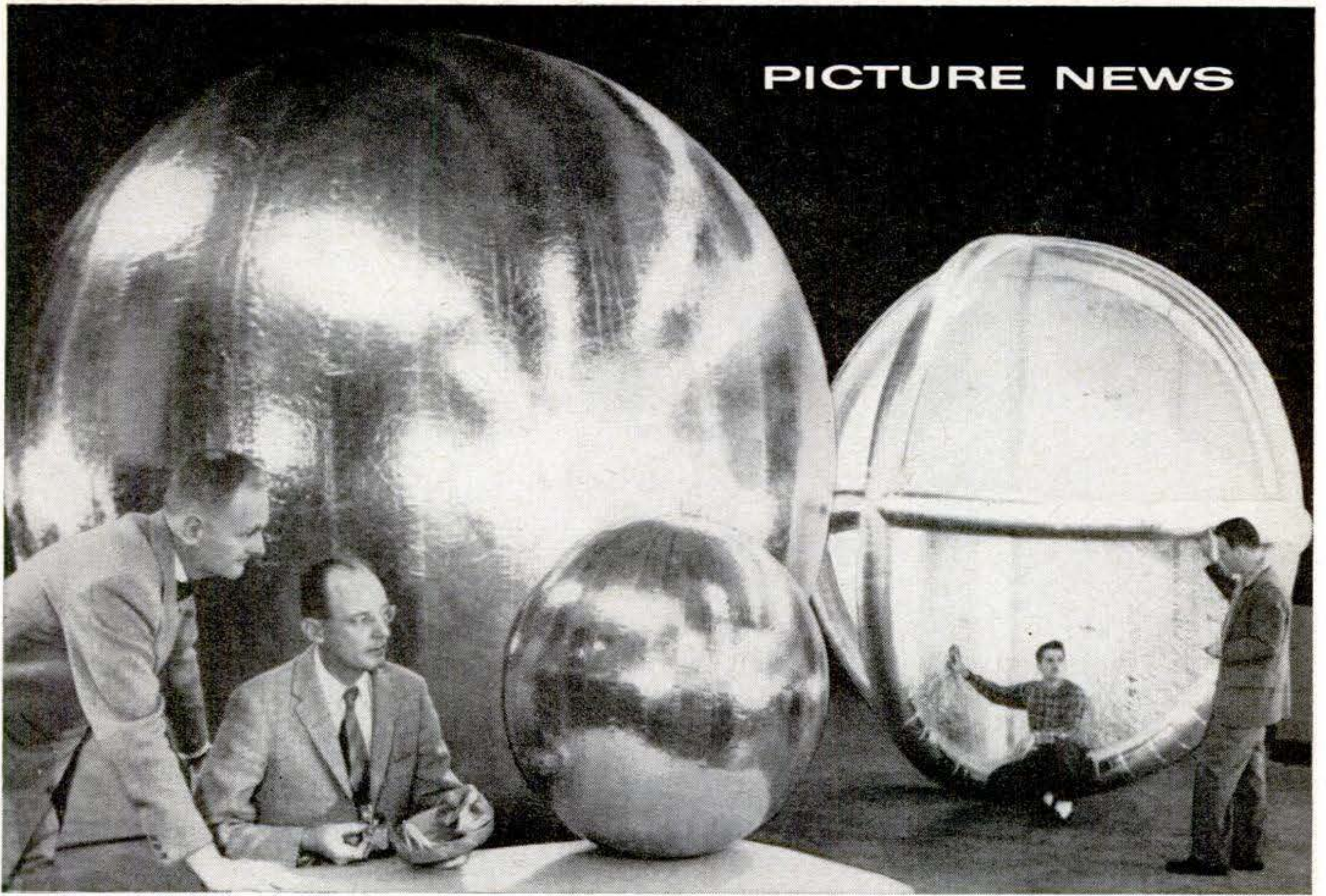

Sub-satellites made of aluminum foil. Easiest to see of all man-made satellites is the shining 12-foot aluminum balloon at left designed for launching, collapsed, in a Vanguard nose cone. It will be inflated by nitrogen. In the foreground are two 30-inch versions, blown up and folded flat, and at right a corner reflector that bounces radar waves. All are made of Reynolds foil similar to that used in kitchens.



Carpet of flowers. This roll-out mat needs only watering to grow flowers all summer. Made of organic material, it contains 30 different kinds of seed, weed killer, and enough plant food to stimulate several months' growth. Photo at right shows the flowers beginning to bud. Mats come in rolls $\frac{1}{4}$ inch by one foot by 18 feet. They can be cut to flower-box size. Horticulture, Inc., New York City, sells them at \$3.98 a roll.

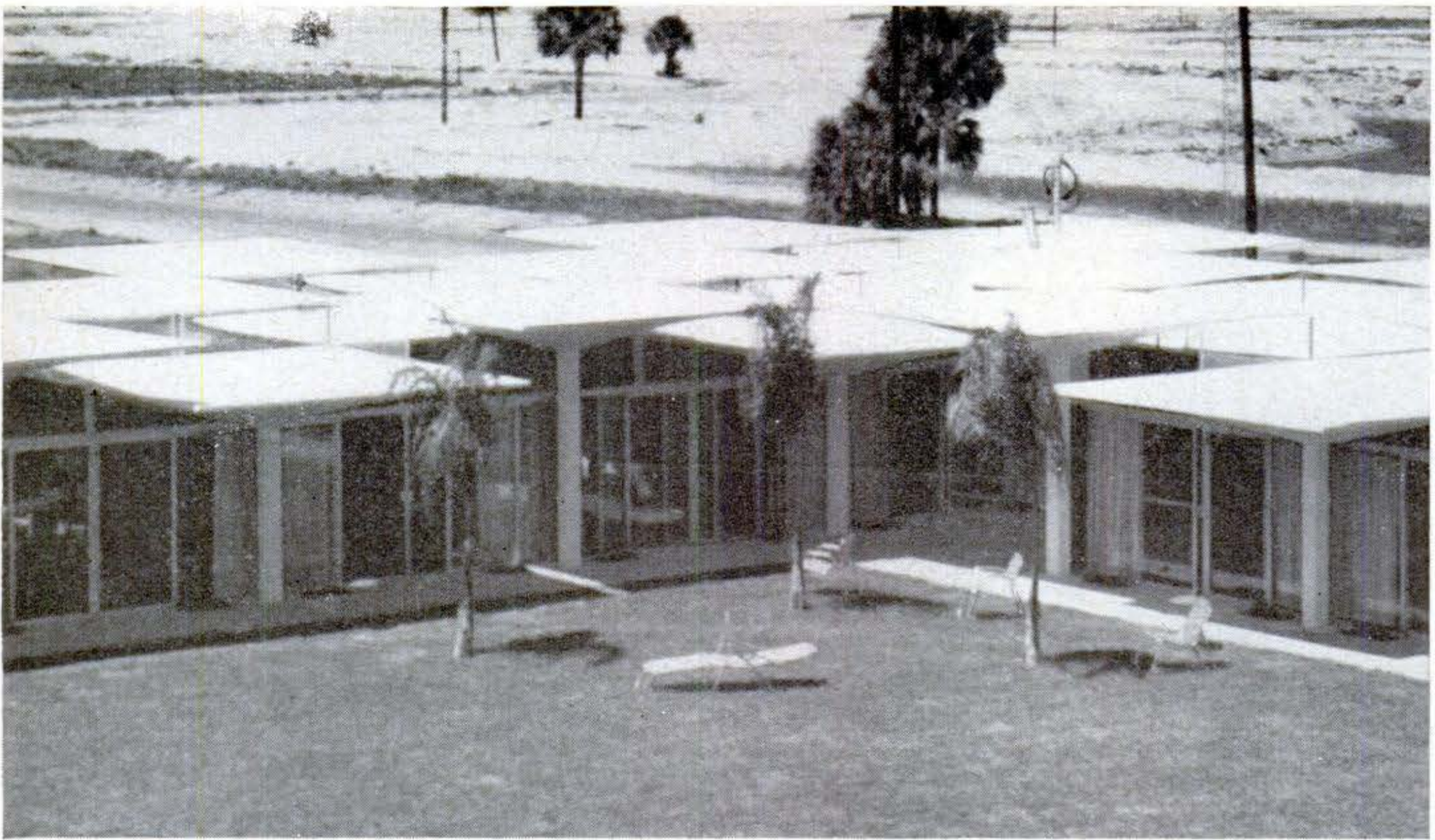

Cocktail-glass roof. Concave slabs of concrete, each supported by a single stem, form a roof for a motel near Venice, Fla. It's said to be hurricaneproof.

Shells are placed on two staggered levels, each a few inches higher or lower than its neighbor. Rainwater drains into a pipe embedded in each central column.

At right, a precast roof section goes into place with old tire casings on the ends of derrick ropes to prevent damage to the corners. The design won an award for architect Victor Lundy of Sarasota.

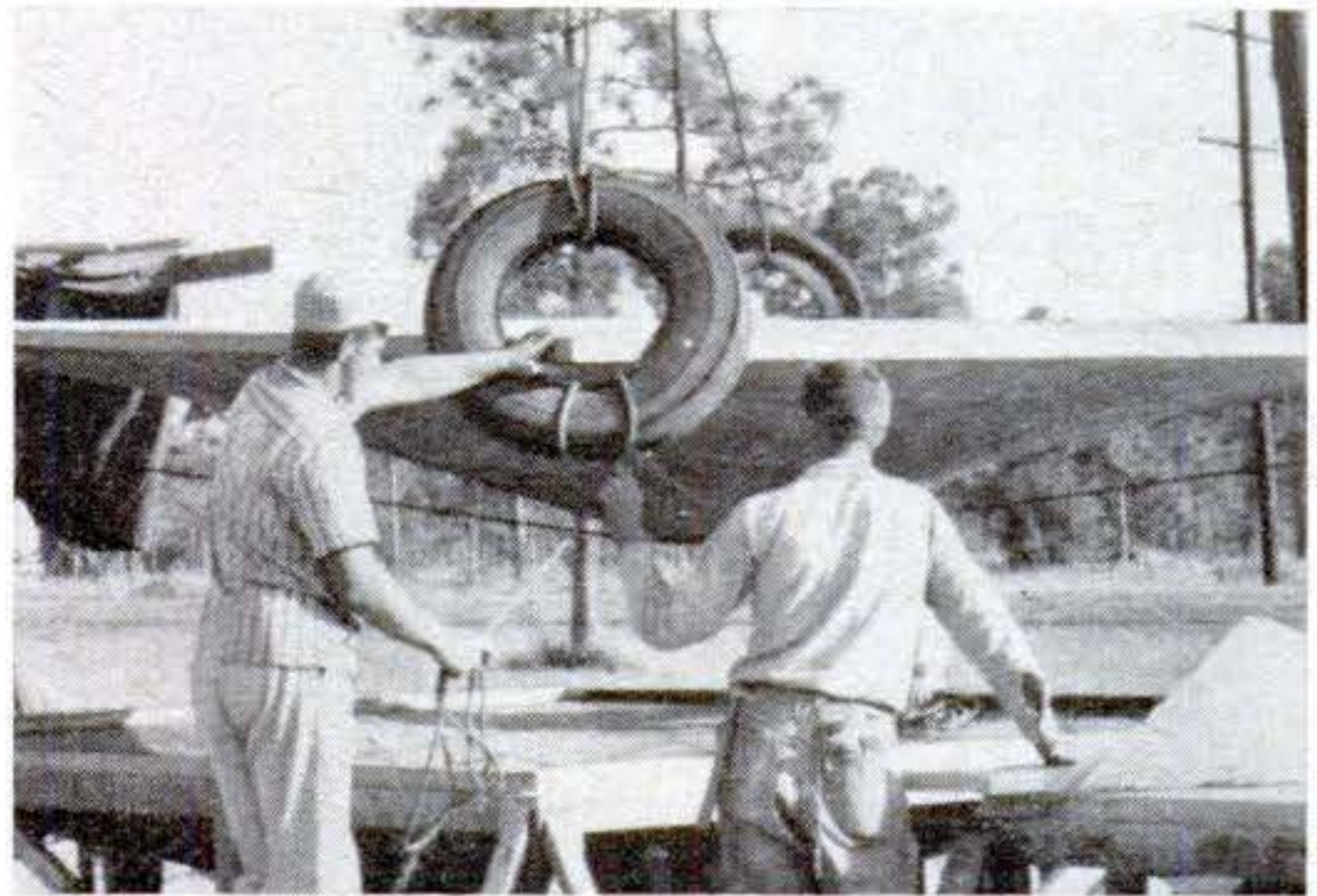

Air-curtain refrigerator. A gentle flow of air is the only door in this vertical refrigerated display case in a Minneapolis supermarket. Shelves (seen below from rear) are motorized endless belts. Lifting the last carton of milk or other item from front row actuates the motor to bring up the next row of goods. The shelves are reloaded from the rear.

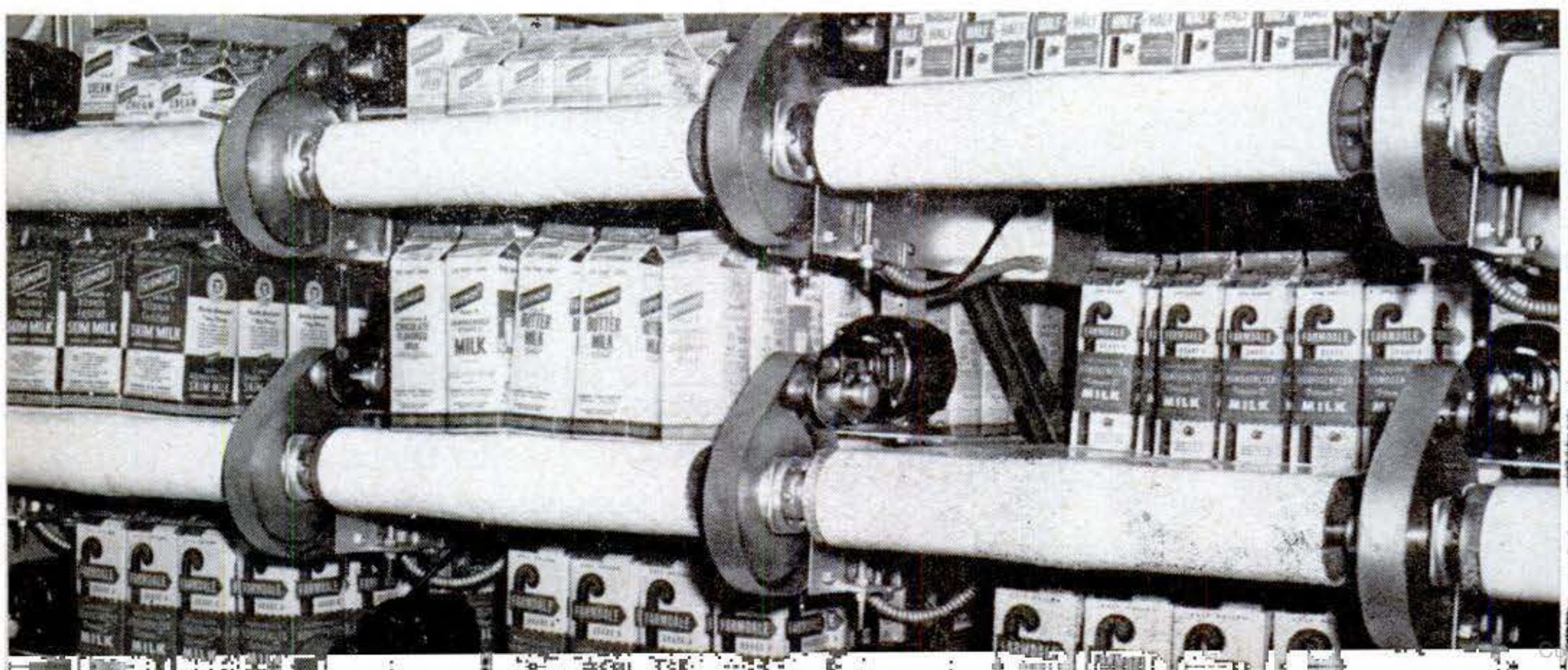

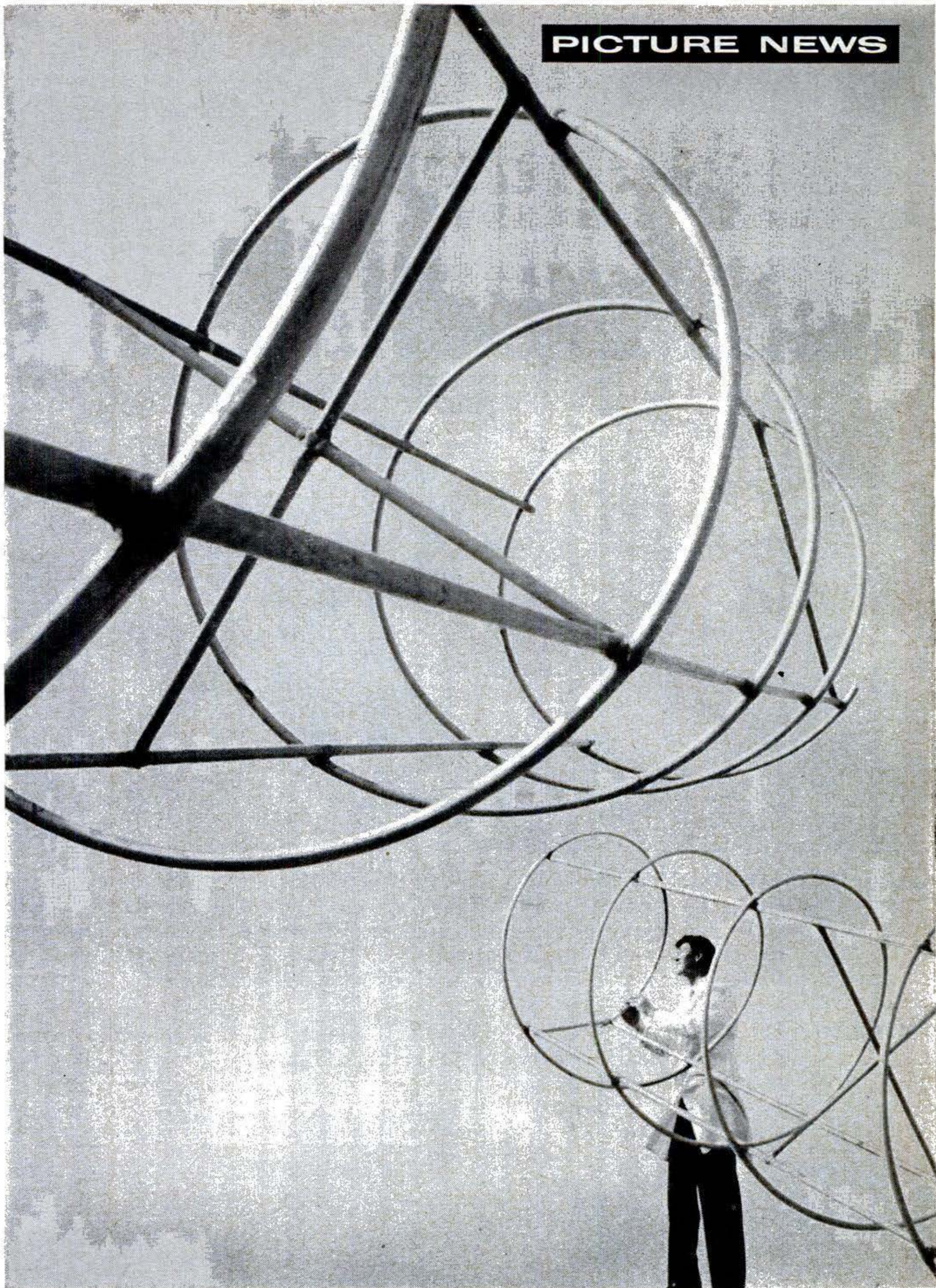

Catching signals from outer space. These circular antennas will pick up radar signals from the Atlas ICBM as it streaks through the ionosphere—the area 50 miles up and extending far into outer space. They'll help scientists at the Cape Canaveral, Fla., test center gather data on electron density, an important factor in missile guidance and radio communication.

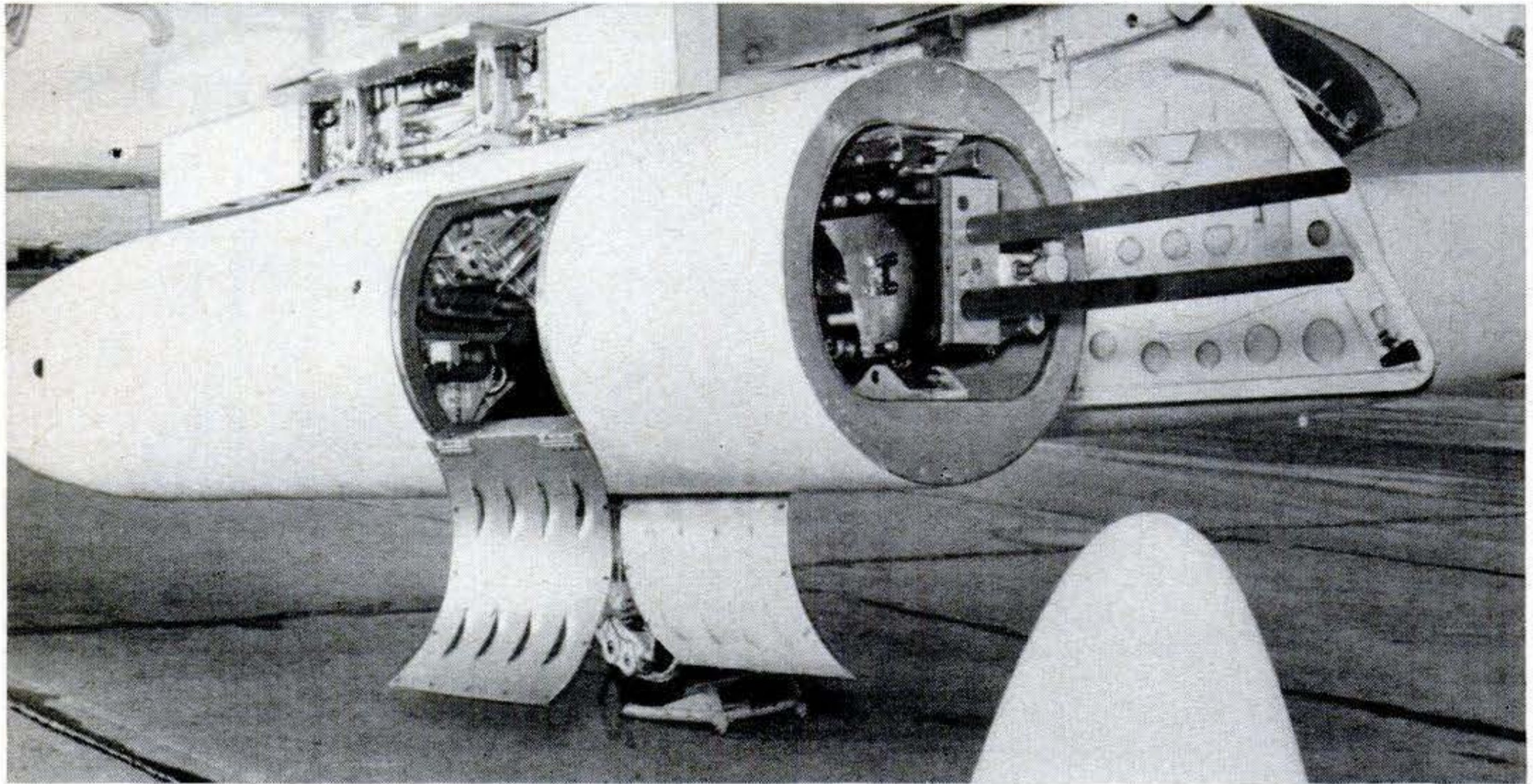

Gun-in-a-pod. Here the Navy shows its new Mark II aircraft gun for the first time. It's a double-barrel 20-mm. automatic cannon that delivers eight times the firepower of similar guns of World War II. It was developed by Hughes, and can be attached or detached quickly, jettisoned in flight. Here gun and pod are on a Douglas A4-D Skyhawk.

Russian bus rides the waves. The "aquabus" below is now in regular service on Soviet waterways. Its cabin is fitted like a highway bus, but it carries 66 passengers at half standard bus fare. The hydrofoil craft is 90 feet long, has a 15-foot beam, is powered by a 900-hp. motor and rides three feet out of the water at the prow at top speed, 43 m.p.h.

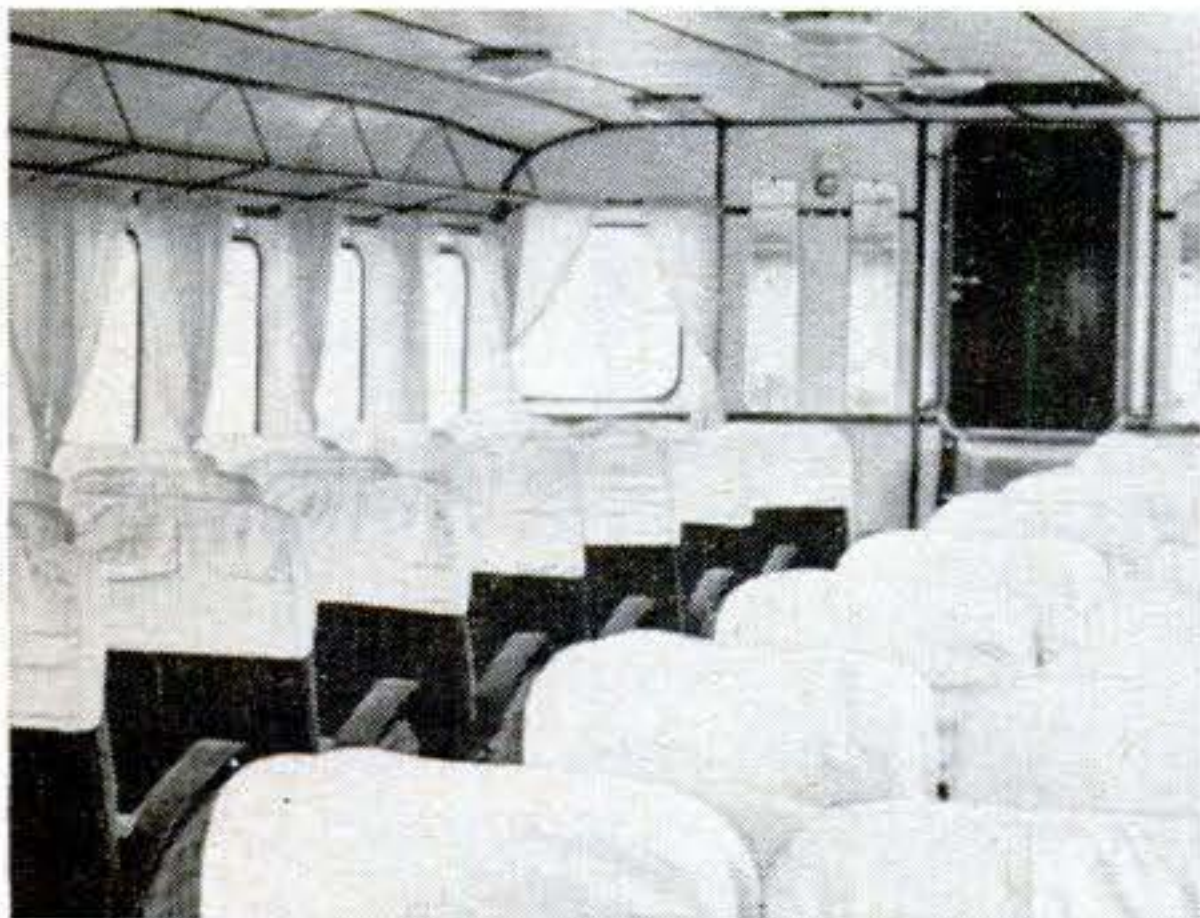

What Are Your Chances If You Meet a Shark?

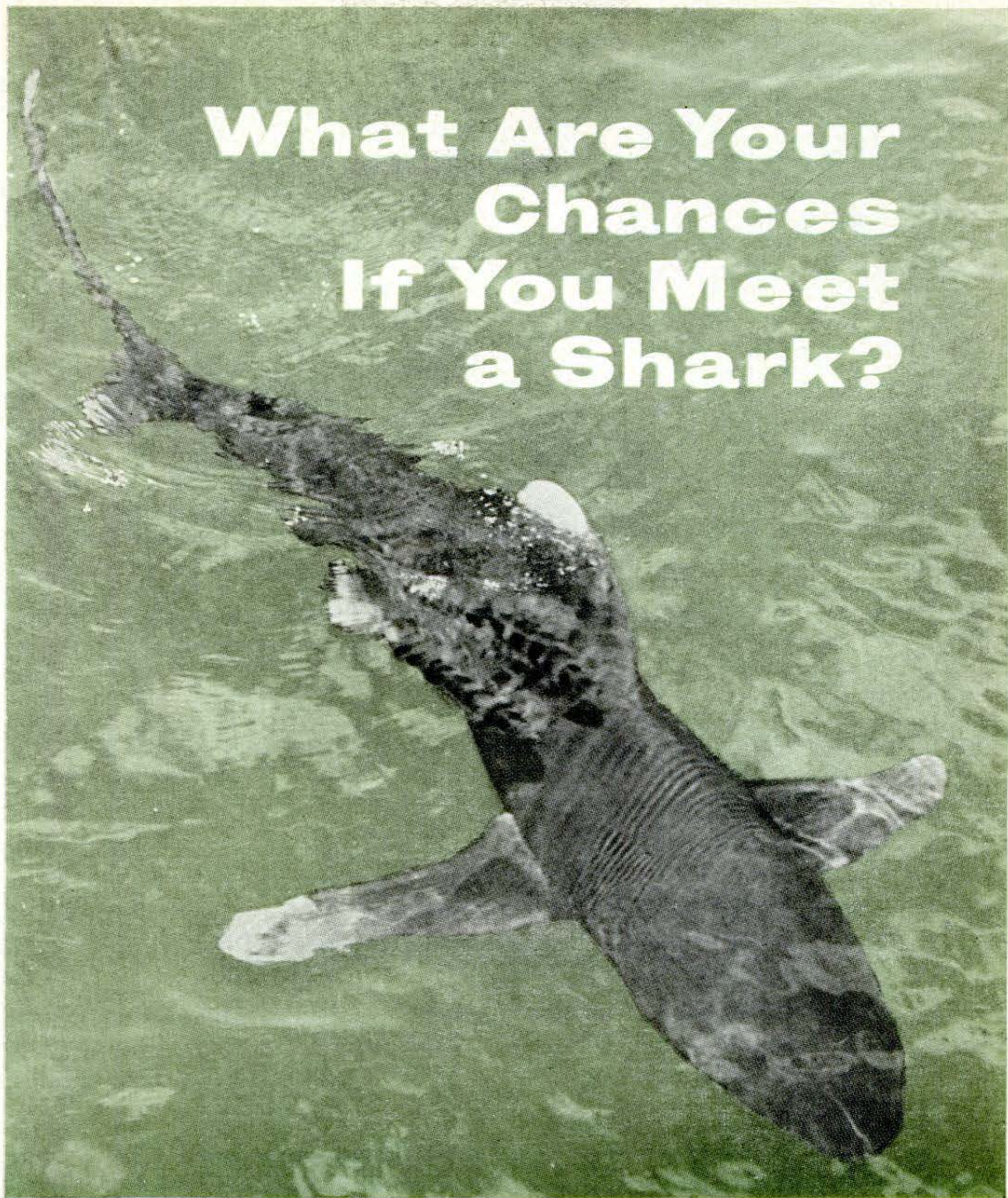

The white-tip, an accused but not proven man-eater, plies the Atlantic. Note two pilot fish.

The biggest is so lazy you can bump right into him—but DON'T try that with the man-hungry White or the Hammerhead

By Gardner Soule

THE most qualified man I could find answered my question: "Do sharks attack people?"

"They do."

Afloat and ashore, Harvard's Bill

Schroeder has studied sharks for 40 years. He has hauled them up from Nova Scotia to the West Indies. At Harvard and at the Woods Hole (Mass.) Oceanographic Institution where I found him, he pores over reports of their activities. Schroeder and Dr. Henry B. Bigelow, also of Har-



OXYNOTUS' TOOTHY GRIMACE is familiar sight to Mediterranean fishermen.

Sharks' innards have revealed sea

creature known as *the man-eater*: the White shark. He is by no means active only near Australia. In fact, he is cosmopolitan: He roams the tropical and temperate oceans of the world. He shows up as far north as the Gulf of Maine. He is the only shark known to battle small boats. Last summer in Massachusetts Bay a harpooned White turned on a boat and bit it. "Left quite an impression of his teeth," says Dr. Schroeder.

vard, are the authors of the outstanding encyclopedia of sharks: Volume I of *Fishes of the Western North Atlantic* (Sears Foundation for Marine Research, Yale, \$10).

I asked the question because a number of people, including some skin divers, are going around saying sharks are harmless. "Not true," Dr. Schroeder says. "There are too many verified instances of sharks attacking men."

He showed me an account of a man fatally bitten off North Carolina. "In the West Indies, where I've been often," he said, "some of the native divers go down among sharks without hesitation. Still, every now and then one gets bitten."

"Around Sydney, Australia, there's a large number of attacks—the most anywhere." These Australian incidents are likely to be tragic. The records show that one in two persons bitten by a shark there dies. So Australia has put wire netting around some of its beaches, and has established a shark patrol—guards who watch for fins cutting the water.

"Of course I don't say that all species of sharks attack men," Dr. Schroeder continued. "Most don't. Not even all of the species known popularly as man-eaters are suspected by scientists of being dangerous. But there's always a bad actor that comes along."

The species that makes the Australian beaches the world's most fearsome is the

That a White shark could swallow and digest a large hunk of man is indicated by what actually has been found in their stomachs: entire sharks four to seven feet long, a whole 100-pound sea lion, seals, sturgeons and turtles. Nor does he limit himself to sea fare. He has also swallowed horse meat, mutton, pork, and once a whole Newfoundland dog complete with collar. One shark, when opened up, was found to have gulped down a packet of ship's papers, and he is suspected of having been a White. But it happened too long ago to be sure.

Back in 1916, four people were bitten to death off New York harbor. A White shark, caught a few days later, may have been the culprit. This man-eater is one of the big sharks: A specimen caught in Cuba weighed 7,000 pounds, had a 1,005-pound liver, and was 21 feet long. But Australia claims the whopper: The Aussies hauled in a 36½-foot White, with teeth three inches long. You can see his jaws in the British Museum in London.

"I DON'T mean to imply that off New York or New England you're in great danger from White sharks," Dr. Schroeder says, "because you're not. They are not really plentiful anywhere—even around Australia." Besides the New York incident, the only other 20th Century fatality off the U.S. northeast coast that probably was due to the White shark was that of a boy fatally bitten in 1926.

Statistically, your chances of being bit-

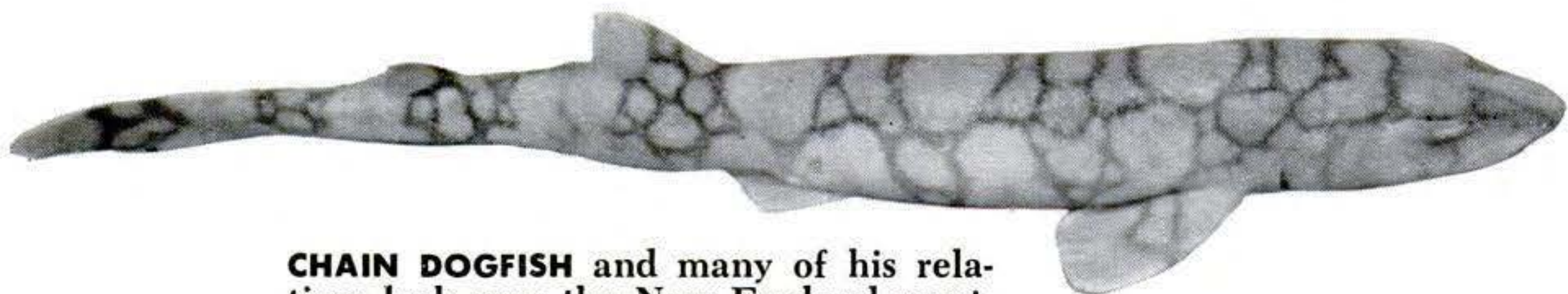

CHAIN DOGFISH and many of his relatives lurk near the New England coast.

lions, ship's papers, Newfoundland dogs, shoes—and men

ten, near any American beach, are very, very remote. Unless, of course, it is known that a shark of a dangerous kind has been in the vicinity.

One thing to give a swimmer pause: The stomachs of many sharks, especially the larger ones, when opened, are often found to contain nothing whatever. So it is probable that sharks are usually hungry.

The White shark is not the only man-eater you may encounter off U. S. shores. There is the Hammerhead. He is one of the cannibal sharks—known to consume other Hammerheads. According to an early account, one Hammerhead was found to contain some human remains. Had the shark been the killer? There was no way of telling. Then came a verified attack by a Hammerhead upon a swimmer at West Palm Beach, Fla., in 1913.

Hammerheads in great schools swim north along the Atlantic coast in summer. They go right into coastal bays, even into New York harbor. They grow to 12 or 13 feet and 900 pounds and when hooked they put up a shark-sized battle.

THE contents of stomachs tell much about sharks, and of all those that show up off the U. S., the Tiger or Leopard has displayed the most voracious appetite. He has contained: sting rays (poison spines and all); great chunks of sharks, including other Tigers; crabs, birds, sea turtles, spiny lobsters, skates; and even such indigestible items as lumps of coal, tin cans and empty sacks.

The record Tiger, caught in Cuba, was 18 feet long. There and in the rest of the West Indies he's considered the most dangerous shark. Australians began to agree when, on one occasion, they caught a Tiger and he vomited up a man's arm. But the arm was proved to have come from the dismembered body of a murder victim. Besides his appetite, the Tiger has another attribute that could qualify him to be a man-eater: His big, coarse, rolling teeth cut like a saw through the cast-iron hides of other sharks and the shells of the biggest sea turtles. It is possible that he also eats men; proof is lacking.

Stomach contents can sometimes be misleading. A tremor went around the world a few years ago when one shark,

caught near the Philippines, was opened and found to hold 47 buttons, three leather belts, seven leggings, and nine shoes.

All this incriminating evidence came out of the belly of a specimen of the world's biggest fish: the Whale shark. He is known to reach 45 feet and may attain 60. One caught at Knight's Key, Fla., weighed over 25,000 pounds.

The evidence, however, did not mean what it appeared to. For the Whale shark eats plankton (minute one-cell plants and

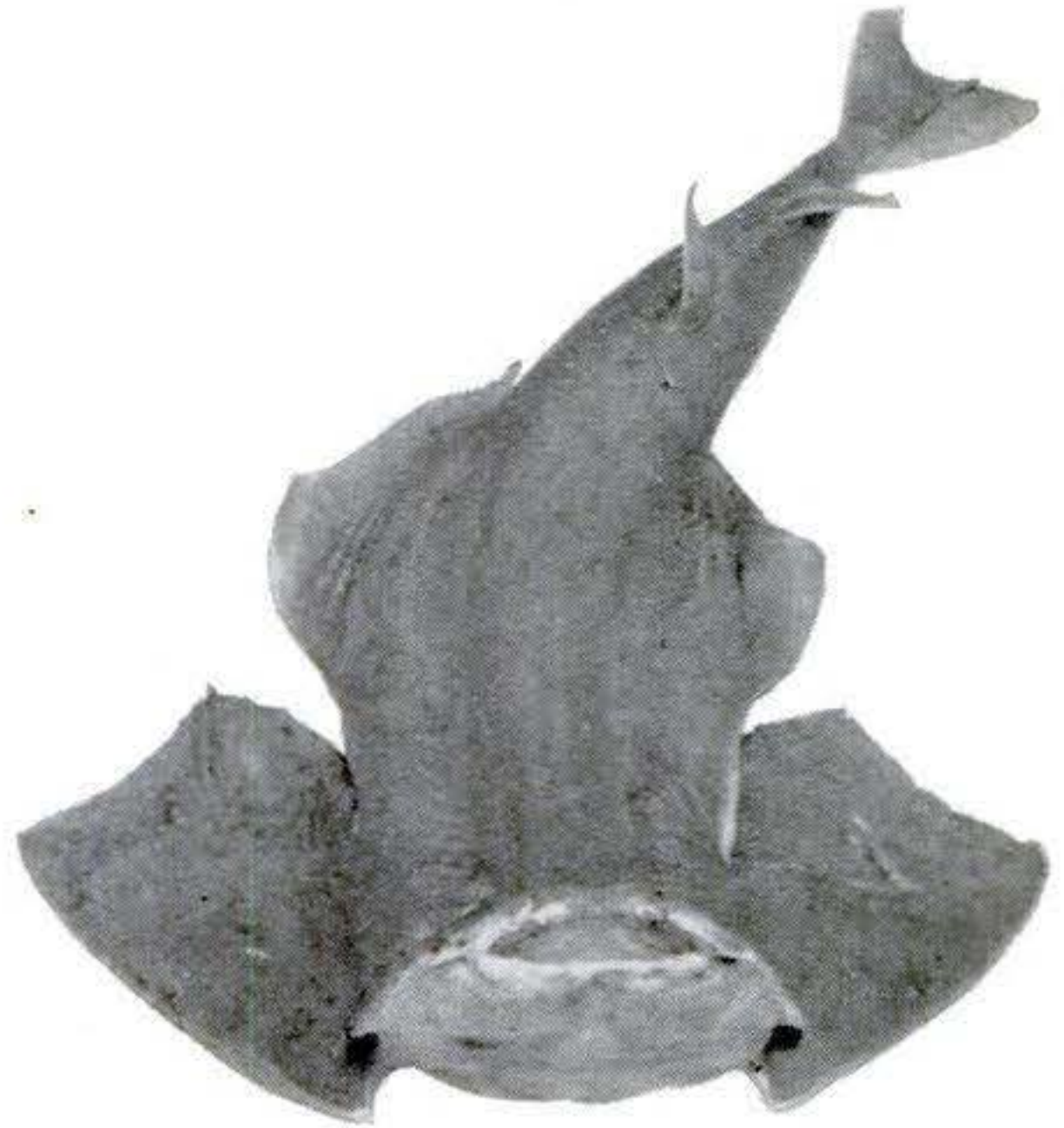

THIS ANGEL SHARK was caught in shallow water off the coast of Massachusetts.

animals), crustacea and small schooling fishes. He obtains this food by cruising slowly on the surface with his mouth open, and gulping anything—including buttons, belts, leggings and shoes—that floats in. His danger to man is not his bite. He moves so slowly that he won't even get out of the way of your boat. You can bump right into him, and some ships have. But he can deal you a lusty swat with his giant tail.

Next biggest shark, the Basking, eats the same things and obtains them the same way. He gets to be 35-40 feet long. A 30-footer weighed 8,600 pounds. If you see Basking sharks, as you're likely to do off either the Atlantic or Pacific coasts, you'll not forget them. They are found in schools of possibly 100 or so. Many people think they're sea serpents. This is because their snout, back and a couple of fins often show above the surface, and because they sometimes swim in line after

each other—the caravan looking like one long, writhing animal.

The stomach contents of the Mako, another suspected but unconvicted man-eater, are also impressive. One 730-pounder contained a 120-pound swordfish, the sword almost intact. Another Mako, over 10 feet long, weighed 1,009 pounds.

THERE are two other accused (but unproved) attackers of men among sharks on U.S. shores. One is the Lemon, of Florida and the South. He's strictly an inshore species, and is known to eat refuse around wharves. Though charged with attacking bathers off South Carolina, he hasn't been proved guilty. He reaches over nine feet.

The other is the Bull (or Ground) shark, a 10-foot, 400-pounder that hugs the shore and is caught from docks and in harbors at Galveston, Tex., Charleston, S.C., Bermuda, and points between. You may even encounter him far inland: He's been reported 160 miles from the sea in Louisiana's Atchafalaya River. The Bull has been called a man-eater, but his tribe is so plentiful that if he did have a taste for human flesh, shark bites would be much more frequent.

Indeed, by far the most sharks you're likely to meet are harmless. Take the Nurse, which frightens people with its fin cutting a surface. This Southern citizen enters water as shallow as one foot deep, lies motionless, lets you approach. He is harmless to men—so harmless, in fact, that Hollywood uses him for the battles it stages with "man-killers of the deep."

Another inshore dweller is the Sand, who will lurk in two to six feet of water anywhere along the Atlantic coast. The Sand is one of the few sharks that have done anything indicating brainwork: Off New Jersey, they are said to have been seen chasing bluefish into shallow water, corralling them to eat them at leisure.

If you go out to sea, you'll find the Great Blue shark: brilliant blue above, snow-white below. He has reached 12 feet, seven inches. He eats herring, sardines, anchovies and flying fish, and he gathers with great numbers of his kind to chew up dead sperm whales. He is a ship

follower, waiting for garbage to be tossed overboard.

Are sharks fast swimmers? Not many of them; most can manage spurts of only 100 feet or so, say the experts. Take the Mackerel shark, found in both the Atlantic and Pacific. One of the most streamlined of sharks, he is a swift, powerful swimmer—in a short chase. Caught, he offers only feeble resistance.

"PEOPLE think of sharks as big," says Schroeder. "That's because they usually see only the large surface ones. But most species are small."

By far the commonest shark, off New England and the mid-Atlantic states, and also found in the Pacific, is the Spiny Dogfish. He reaches only about three feet, runs seven to 10 pounds. He causes fishermen untold trouble by gulping their bait. On a 700-hook line, near Cape Breton, once there were 690 Spiny Dogfish to be gotten rid of.

There are even tiny sharks, mostly from the depths, that nobody except shark specialists ever heard of. There is one that matures and bears young when it's six inches long. There are others, usually small in size, that are luminescent, giving off a vivid greenish glow.

Of all the 250 or more species of sharks, only five or six are reported dangerous to men—and some of these without proof. Most sharks are either too small, too sluggish, too weakly armed, or live at too great a depth to be of any potential danger.

On the other hand, as Schroeder and his partner Dr. Bigelow point out, there are unquestionably species, voracious, large, active, and armed with very effective teeth, that habitually feed on large prey. Such a shark can lacerate a man in a moment so he bleeds to death. One bather attacked by a shark in Florida was saved by 300 stitches. Many are not that lucky.

So if you see a fin or the shark himself, don't wade or dive in to see what will happen. And if you're swimming from a ship or boat at sea, always post someone on deck to watch for sharks. Men like Dr. Schroeder, the men who know sharks best, never take a chance. **END**

Next Month: What makes a 180-m.p.h. boat so fast? Ted Jones, designer of the hottest U.S. hydroplanes, tells you in August PS.

New Ideas from the Inventors

.....

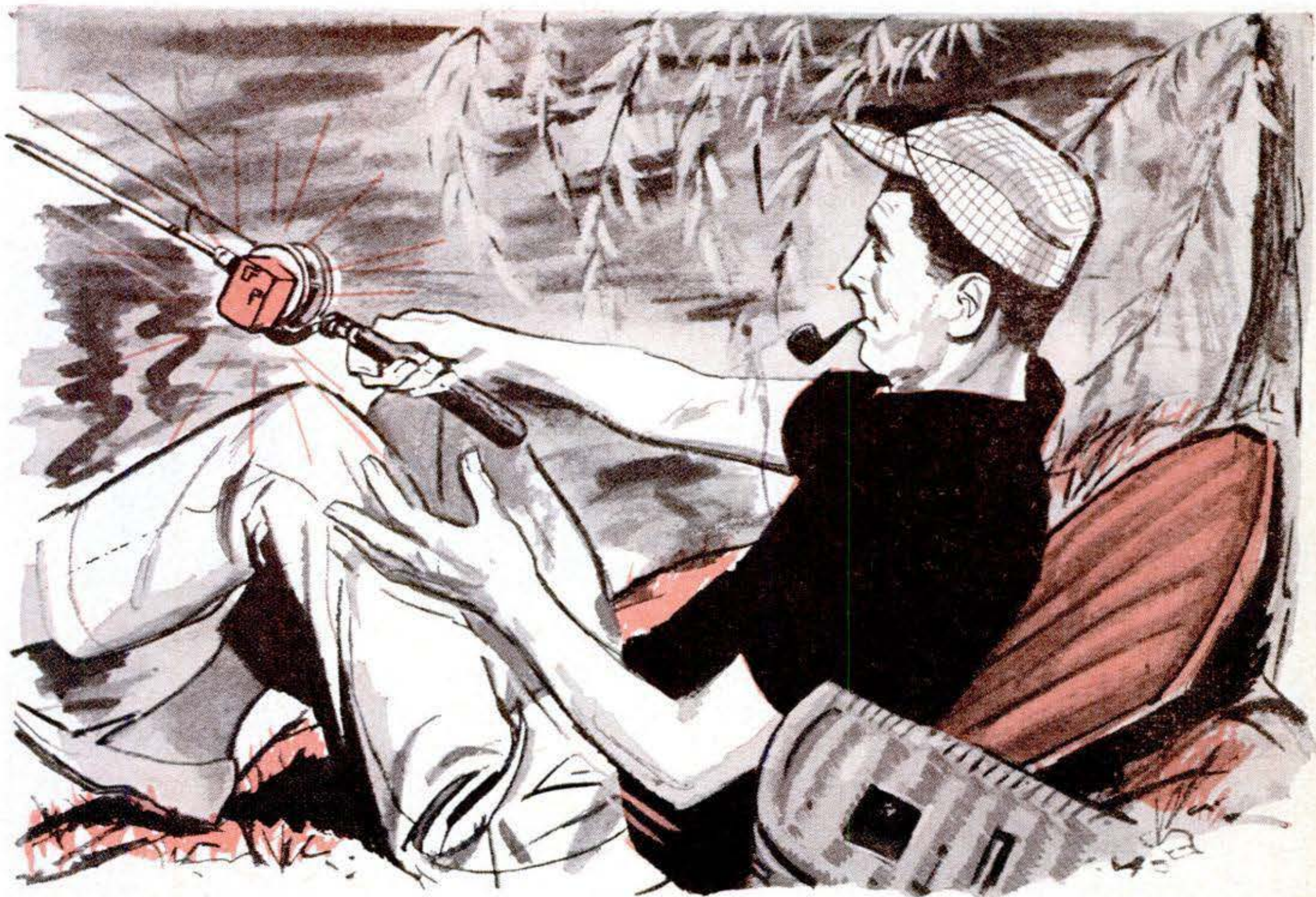

1 Buzzer Lets Fisherman Nap. With this recently patented signal clipped to the side of his reel, an angler could relax between bites. He'd loop the line

over a switch lever so that the pull of a hooked fish would sound a buzzer or flash a light. The signal would also be useful for fishermen who work two or three lines.

2 Ear Form Evens Sideburns. You'd have no trouble keeping your sideburns even—and equal—with an ear-fitting form like this to backstop your razor. Half of the shaving aid would be shaped to fit the left side of your face; reversed, the opposite half would fit the right ear.

3 Car Frame Hangs Clothes. This detachable window rack with its notched bar for spacing the hangers might lessen crushing and wrinkling of clothing on car trips. At stop-offs, you could lift rack and garments together and transfer them to a closet. It would fold for trunk storage.

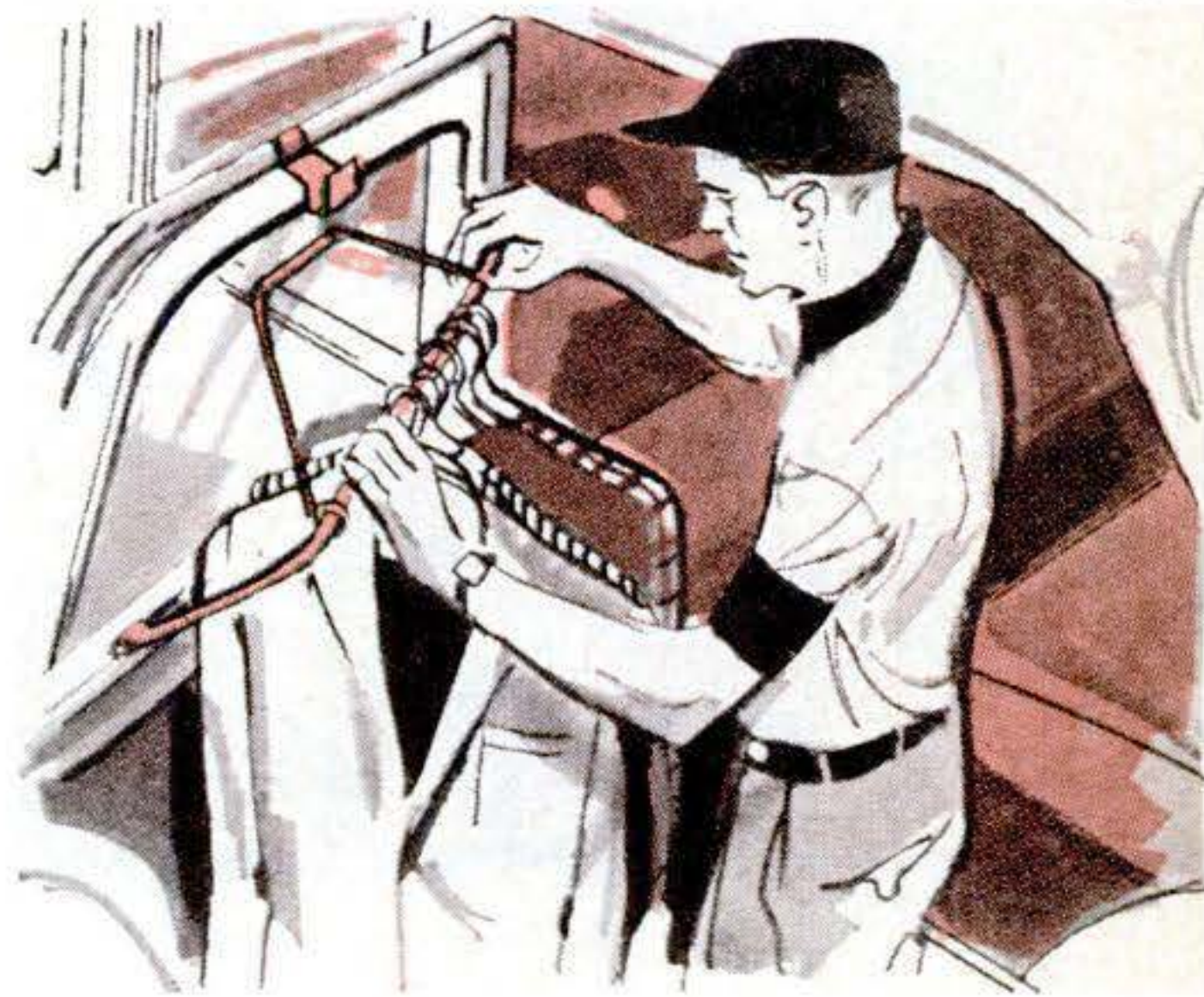

Please turn the page for more new ideas

JULY 1958 113



4 Pool Signal Guards Swimmers. By interrupting sonar-like waves, swimmers in this pool would automatically signal their presence. In one version, a time-delay circuit—and a beam focused across the pool bottom—would sound an alarm if anyone stayed under too long.



5 Directory Dials the Phone. Dr. Lee DeForest, the “Father of Radio,” would use an electrically driven finger—guided by punched cards—to dial frequently called numbers faster and more accurately. The device wouldn’t interfere with manual dialing of unlisted numbers.

6 Canopy Protects Picnic Diners. Sudden rain couldn’t dampen your outdoor meals (nor would flying insects beat you to the salad) if you carried this table-

tent as part of your cook-out gear. The folding frame would clamp to any standard picnic table, and the fitted canopy would enclose table and diners.

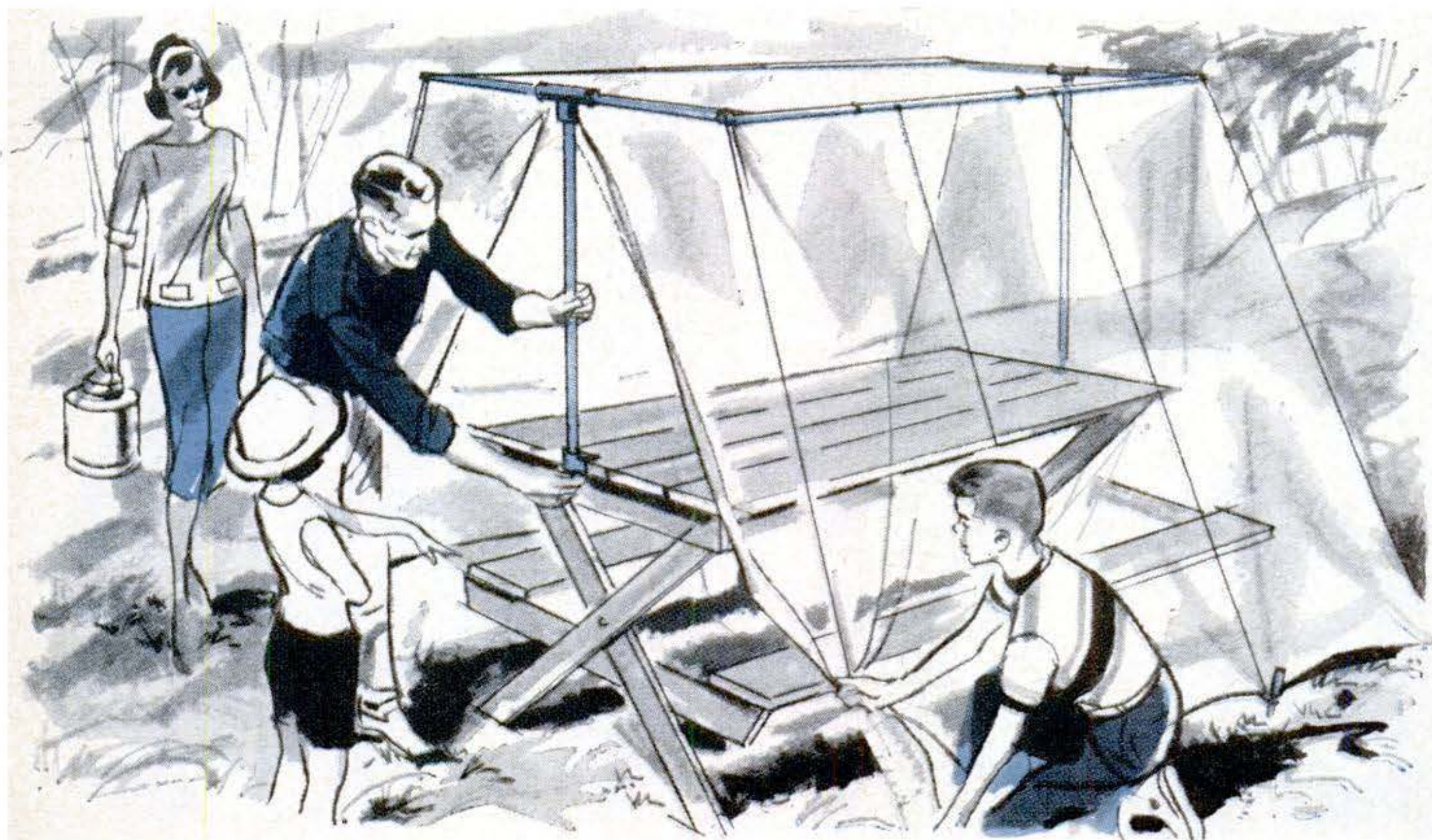



7 Plumber's Rule Checks Angles. To simplify pipe measuring and fitting, this inventor would combine a steel measuring tape with three "bubble" tubes that would quickly check the main pipe settings—vertical, horizontal, and both inside and outside 45-degree angles.

8 One Can Opens Another. If you've ever been on an outing and found that no one remembered to pack the bottle opener, you might like to stock up on beverages put out in containers like these. A metal insert in the bottom of each can or bottle would serve as a cap remover; it would be recessed so it couldn't interfere with normal stacking or storing.

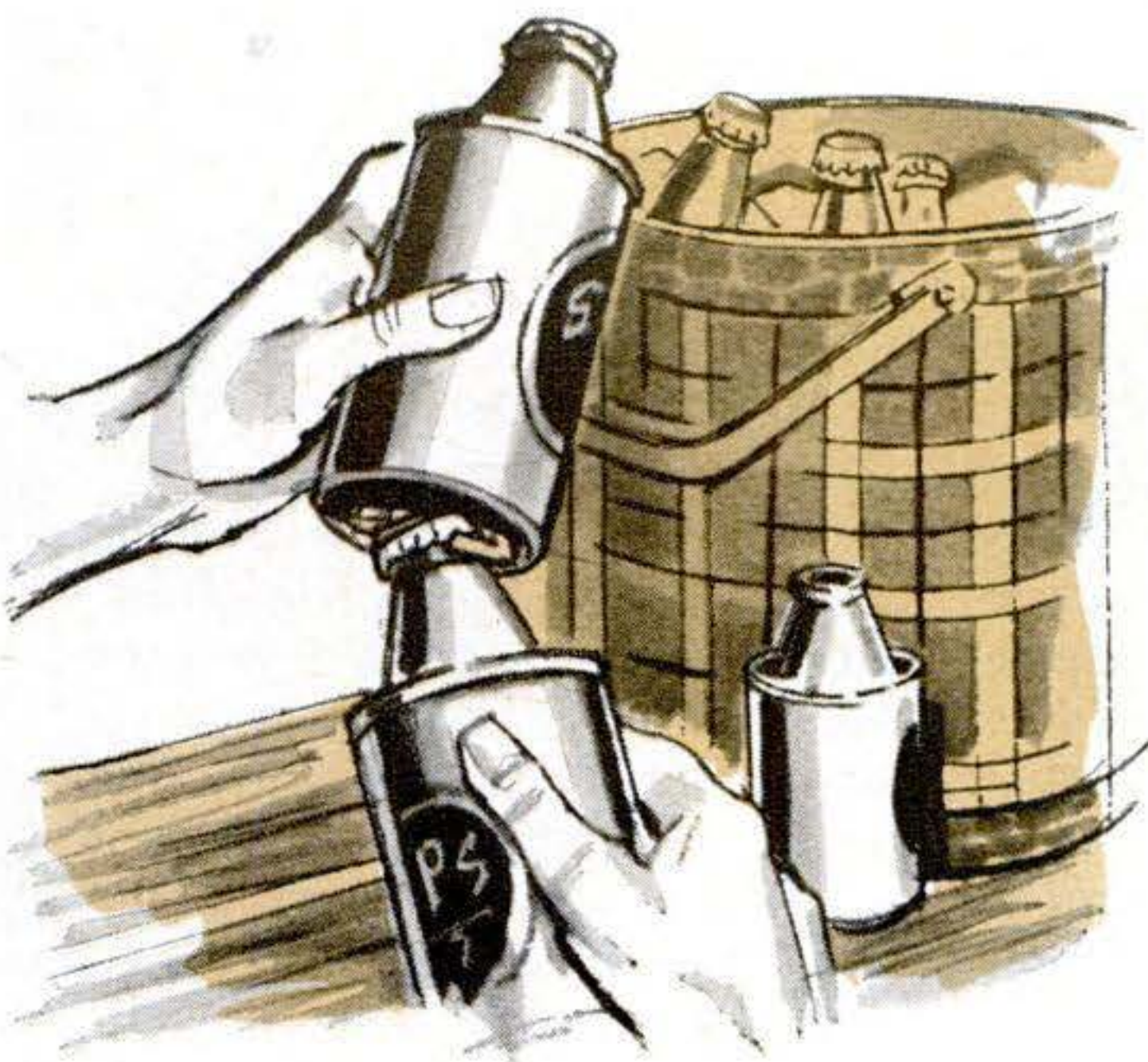

9 Scraper Cleans Ceiling Cleanly. With this long-handled scraper you could remove paint, paper or plaster from a ceiling without ever mounting a ladder. The poised receptacle would catch most of the scrapings. Paintbrushes and rollers that could be fitted to the same handle would help you complete the refinishing job.

The following patents have been issued on these inventions: 1. Patent No. 2,814,900 to R. L. Frazier, Kansas City, Mo.; 2. No. 2,749,922 to J. M. Daniel, Bridgeport, and E. A. Hultgren, Fairfield, Conn.; 3. No. 2,747,781 to H. A. Schofield, Dallas; 4. No. 2,783,459 to C. C. Lienau, E. Orange, N. J., and J. C. Patterson Jr., Falls Church, Va.; 5. No. 2,813,931 to Lee DeForest, Los Angeles; 6. No. 2,790,452 to Carl Dusek, Chicago; 7. No. 2,816,369 to W. F. Becker, White Horse, Yukon Ter.; 8. No. 2,745,301 to Edward Grunwald, NYC; 9. No. 2,820,290 to J. D. Porter Jr., 272 Central St., Rockland, Mass.

Copies of patents may be ordered, by number, from the Commissioner of Patents, Washington 25, D.C., at 25 cents each. To write to an inventor, if the address given above is insufficient, you may address him (by name and patent number) in care of the Commissioner of Patents.



How to Drill Big Holes

Home
and
Shop

**By R. J. De Cristoforo
and J. L. Hamar**

TODAY'S tool manufacturers offer you an exciting variety of bits and cutters especially designed for drilling large holes. They range from the familiar hand-cranked expansive bit to cup-shaped hole saws that whiz through hardwood with the ease of a cookie cutter. Each has its own advantages and limitations. These may make the difference between an easy, neat and safe cutting operation and one that is troublesome and dangerous.

Hand and power bits differ. All hand-turned bits, including the expansive type, have a screw point that provides the feed power. The angle, or "lead," of the screw draws the bit into the wood at a rate more or less synchronized with the slow speed you apply to the brace handle. Power-tool bits, on the other hand, do not have threaded points. The drill supplies the r.p.m.; *you* regulate the feed with pressure.

Not realizing this, many power-drill owners get into trouble by chucking a drill designed for hand cranking in a drill

press or portable electric drill. Rotating at high speed, the screw point embeds itself in the work almost instantly, binds, and turns the part into a flaying knuckle buster. It should have been clamped, of course. But even then the screw would have jammed the cutter and stalled the motor.

There's a way around this problem for the drill-press owner. Clamp the work to the table with a thick piece of scrap below it. Then with a metal drill, bore a pilot hole through both, just larger than the fullest diameter of the screw point. Keeping the stock in the same table position, you can now drill the full-size hole without danger of grabbing. With an expansive bit, you'll do even better by filing the threads off the screw point (the removable cutter makes this possible).

Avoid overloading. You risk burning out power equipment by overloading it. Unfortunately for the owners of $\frac{1}{4}$ " portable drills, there are bits with turned-down shanks that may fit their chucks but require more torque than the motor can supply. Think twice before you use them. If you can't baby one of these bits through stock without excessive jamming,

9 Hole-Cutting Tools for Power Drills

TYPE	DIAMETER OF HOLE	APPROX. DEPTH OF CUT	MATERIAL HANDLED	APPROX. COST
Hole saw*	adjustable to 2½"	1½"	wood, plastics; (metal-cutting blades also available)	\$6.00
Continuous-circle hole saw*	nonadjustable sizes to 2½"	¾"	wood, plastics, metal	\$2.50 (arbor) .90 (2½")
Fly cutter*	adjustable to 3"	2"	wood, metal	\$4.50
Groove-type fly cutter**	adjustable to 6"	1"	wood, plastics, nonferrous metal	\$5.50
Machine bit*** (drills center hole and counterbore)	nonadjustable collars to 1"	5"	wood	\$2.00 (1" size, without drill)
Solid-center bit***	¼" to ¾"	4"	wood	\$6.00 (per set)
Interchangeable flat-blade bit***	⅜" to 1¼"	5"	wood	\$3.50 (per set)
Multi-spur bit***	nonadjustable sizes to 3"	5"	wood	\$24.00 (3" size)
Modified expansive bit**	adjustable to 3"	5"	wood	\$7.00

*Use in drill press, or portable drill if sufficiently powered **Use in drill press only
***Equally good in drill press or portable drill

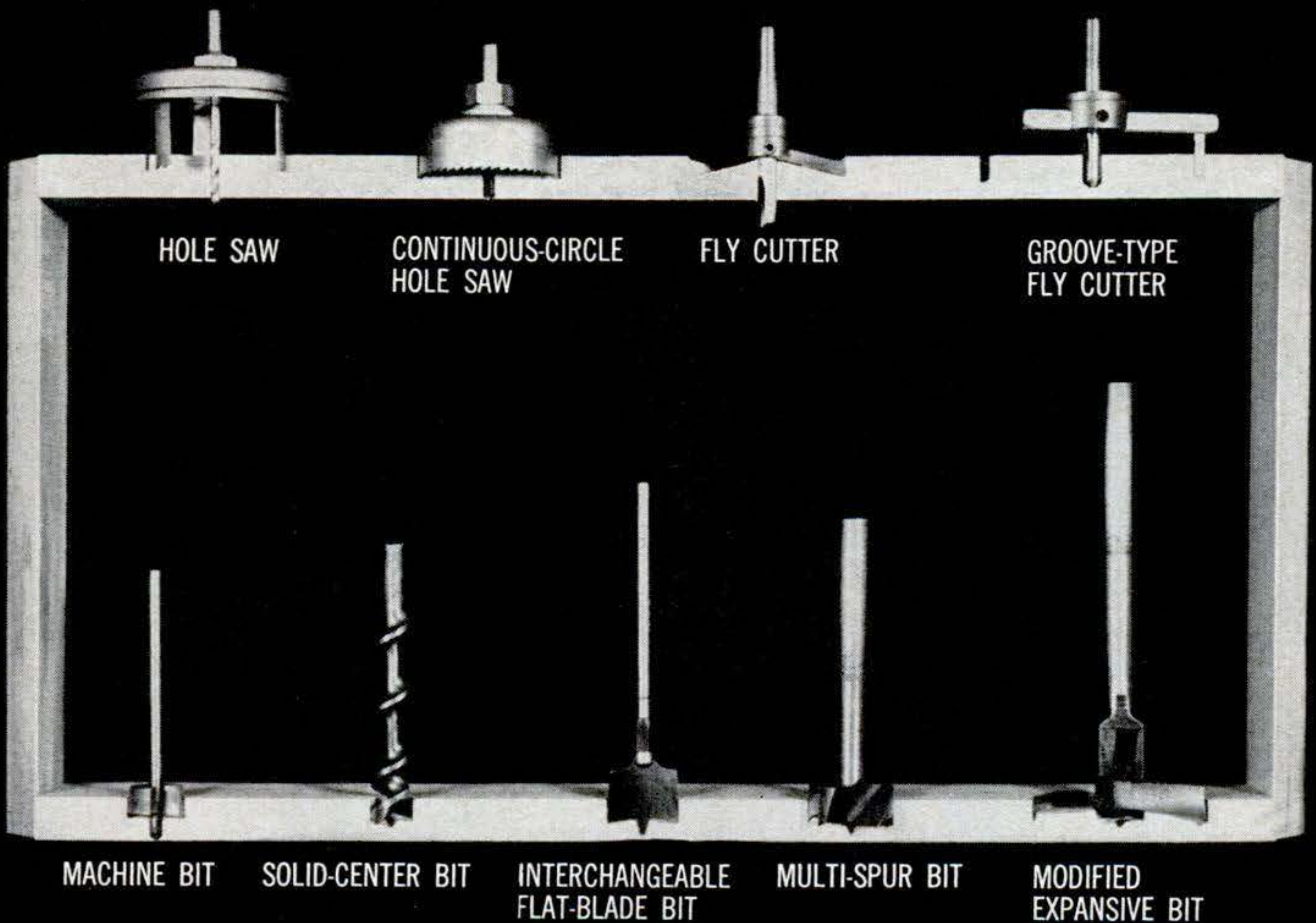

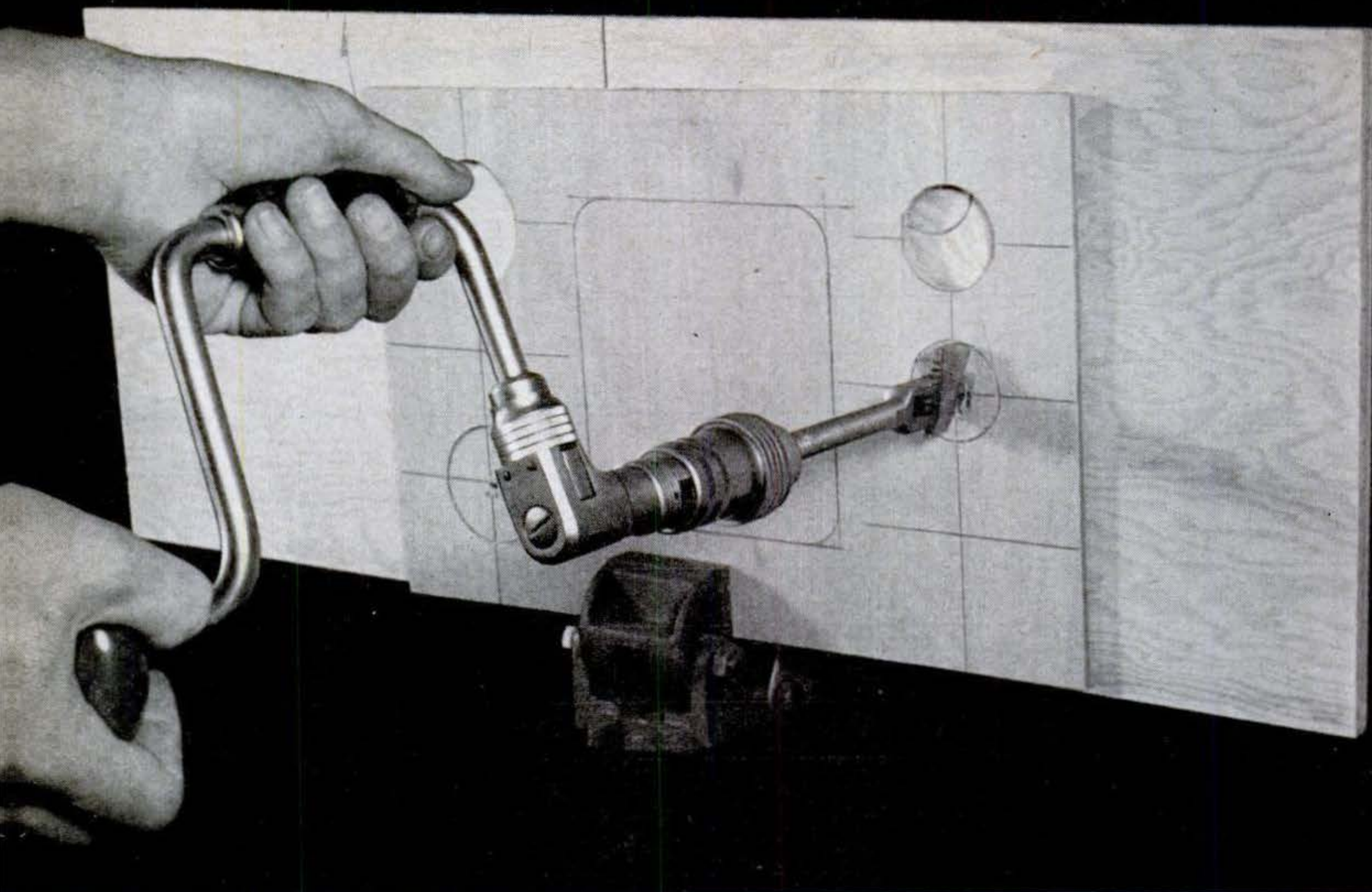

Hand-cranked expansive bit uses your muscle power

"STRONG-ARM" METHOD OF DRILLING BIG HOLES: The cutting blade of the expansive bit is set at the right radius and a screw point provides the

power feed—all you do is supply the r.p.m. Backing the part in a vise with waste stock insures that you get a clean breakthrough.

This fly cutter gives you an inside dividend

GROOVE-TYPE FLY CUTTER has an adjustable, horizontal arm with a vertical cutter at the outer end. Working like a circular dado, it

offers, as a bonus, clean-edged center disks with diameters to 5½". All fly cutters must be run at slow speed, with light pressure.

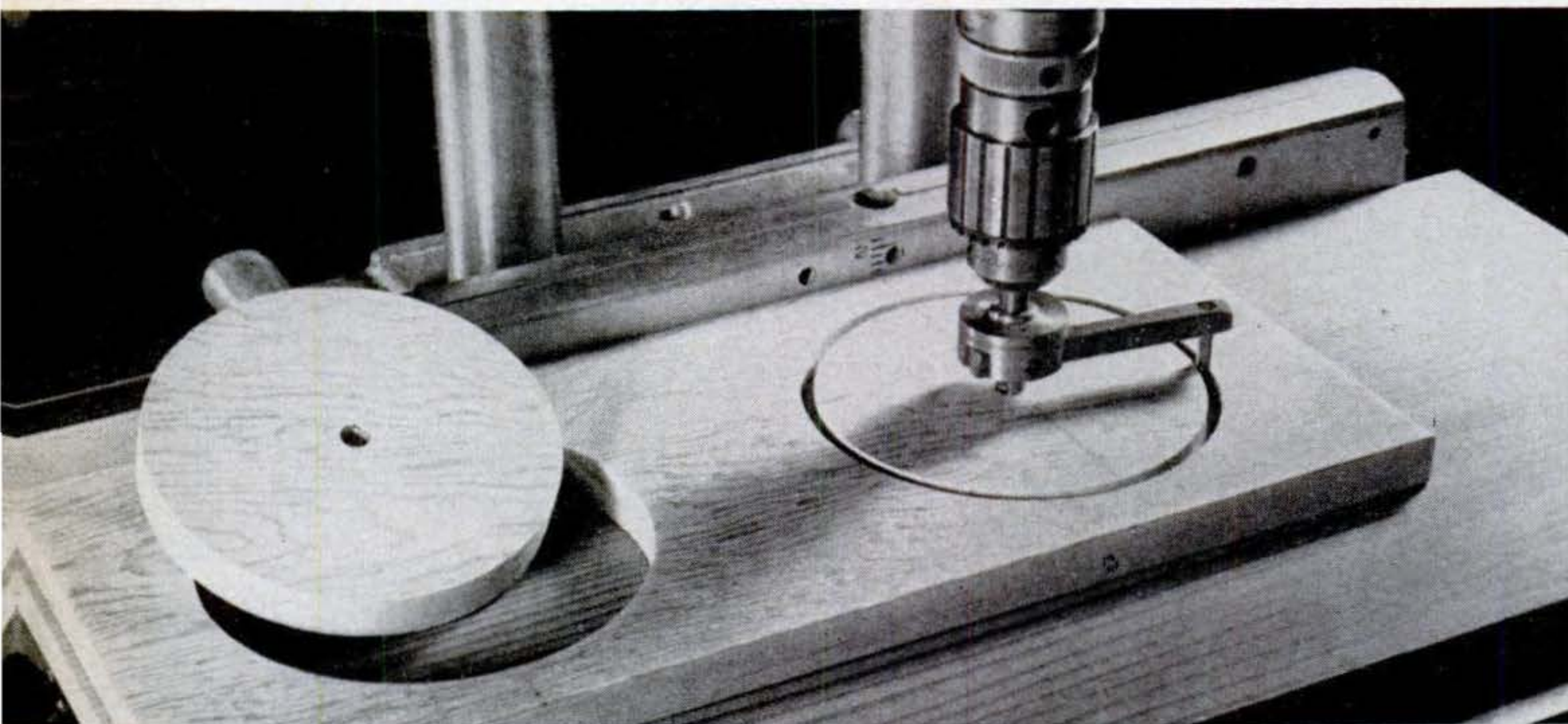

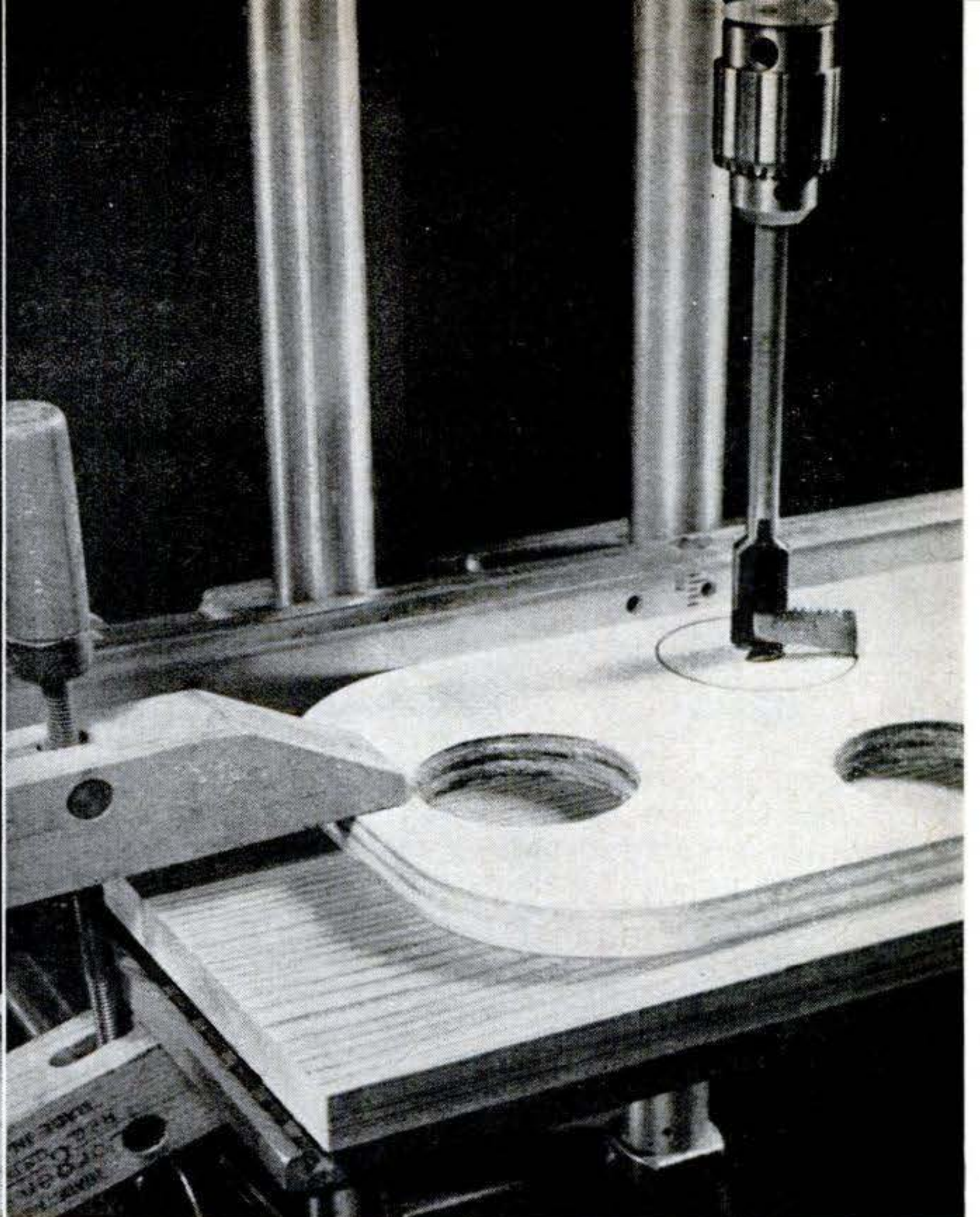
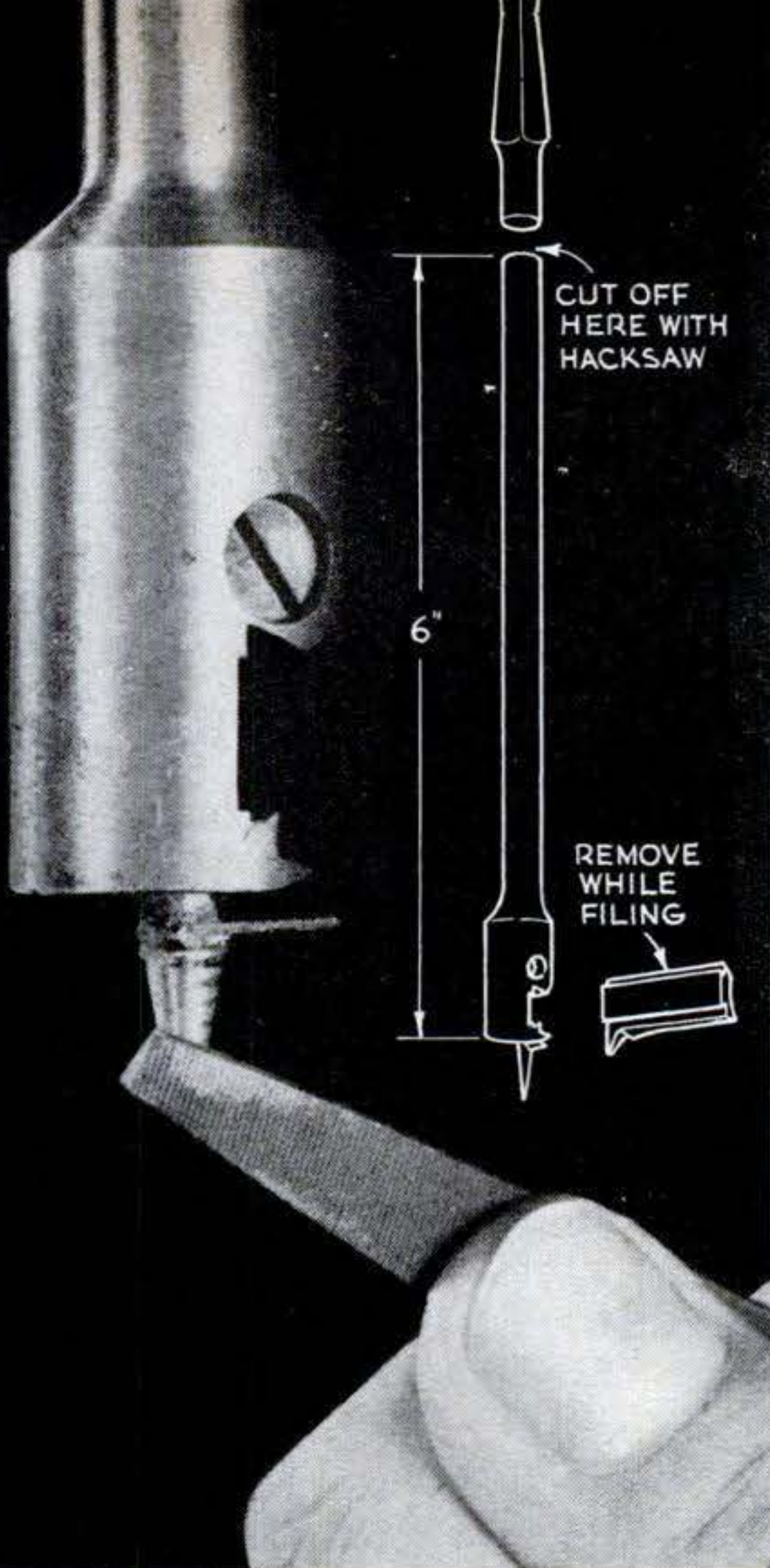

EXPANSIVE BIT IS MODIFIED for use in a drill press by sawing off the squared top section and removing the threads from the screw point by holding them against a file as shown, while running the bit at slow speed. The smooth point prevents dangerous grabbing.

BACK STOCK WITH THICK SCRAP, and clamp both to the table, when using a one-sided cutter. Butting the wood against a guide is further insurance against shifting. Start with slow speed and light feed pressure. Increase both until the bit is cutting steadily and smoothly.

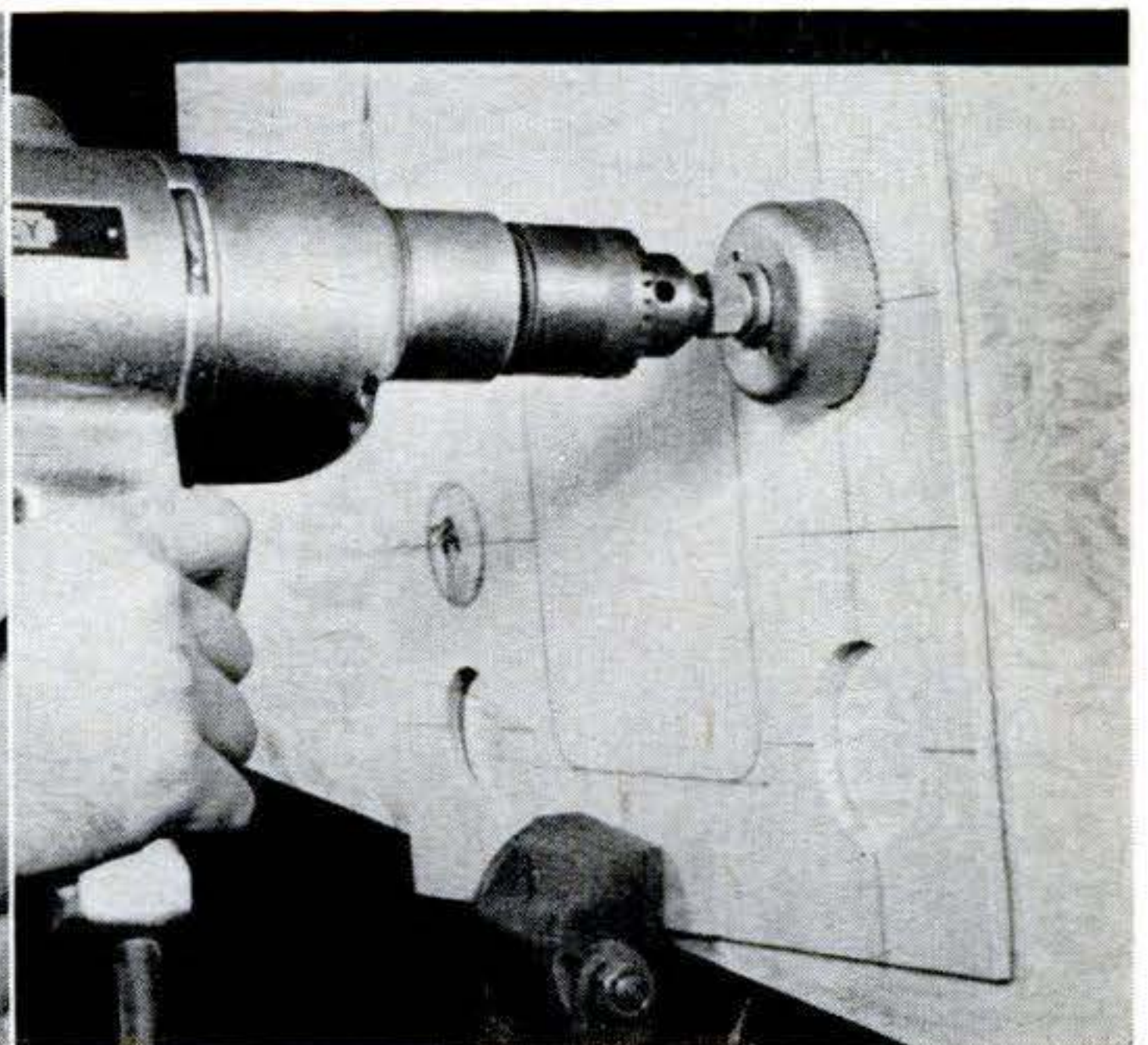

Hole saws trade depth of cut for speed and convenience

FOR HOLES TO 2½" DIAMETER, hole saws offer the smooth and fast-turning characteristics of multicutting blades or continuous saw teeth. Adjustable model at left (you turn the upper disk to get the right setting) can be fitted with

either wood- or metal-cutting blades. The cup-shaped type (right) requires a different saw for each hole diameter. All saws are attached to the same arbor. Heavy-duty portable drills will handle either type of hole saw.

No cutting tool large enough? Then use this trick

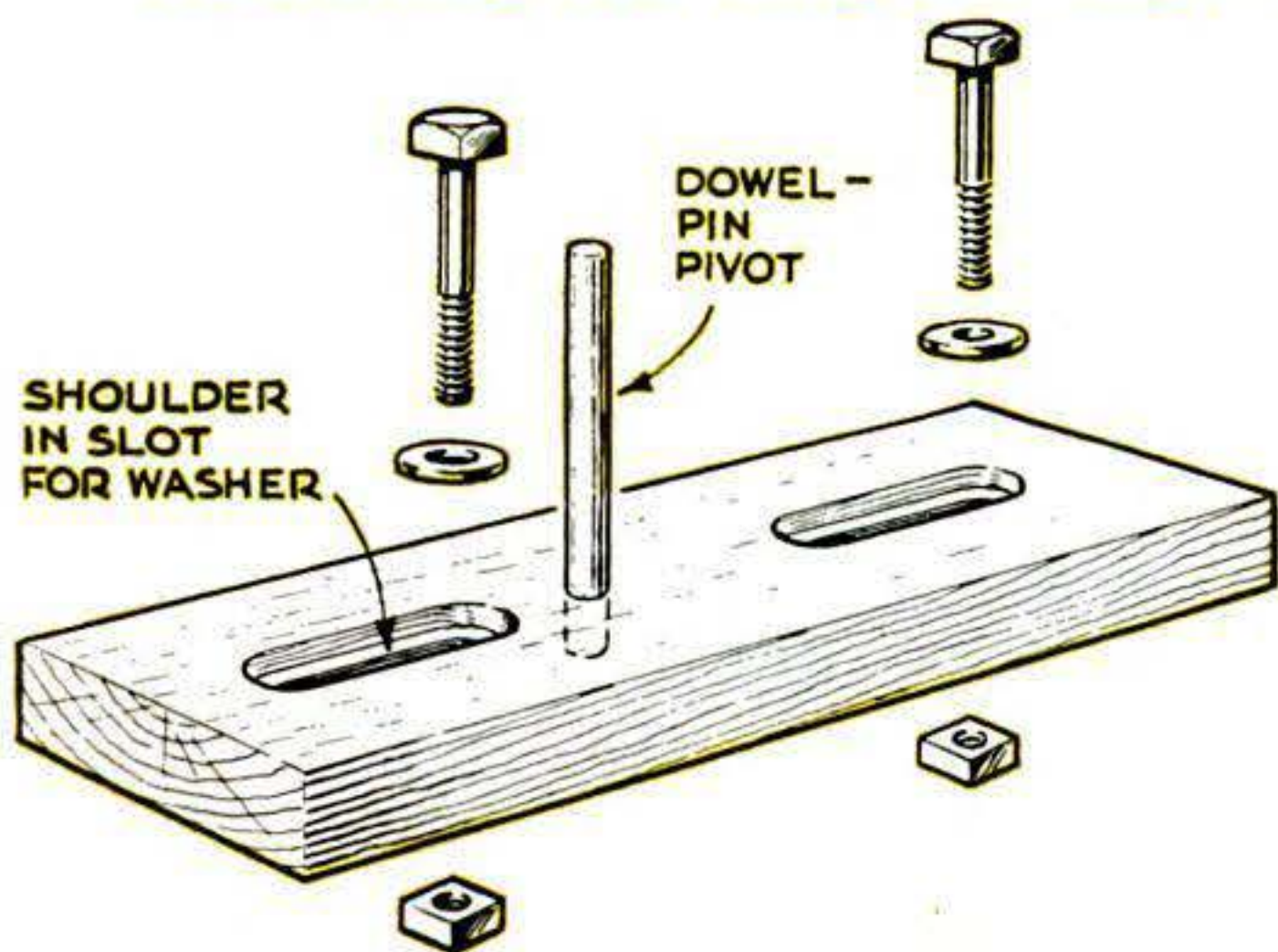

ADJUSTABLE JIG, made from a board and dowel pin, lets you cut holes and disks limited only by spindle-to-post clearance of drill press. A $\frac{1}{4}$ " router bit makes cut.

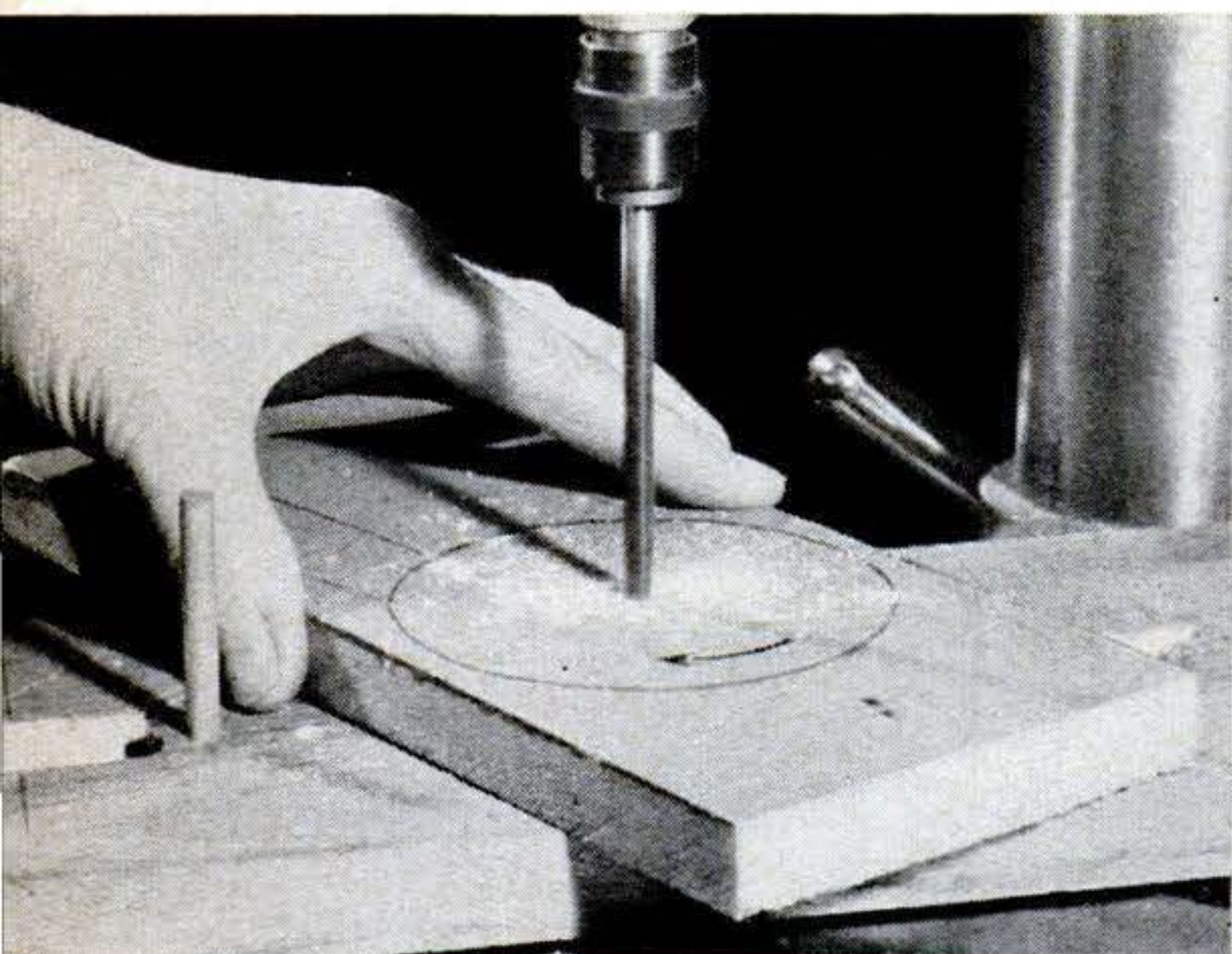

MARK A CIRCLE of the desired size on the stock and drill a hole through its center, using a bit of the same diameter as the dowel pin. Then place the bit in a collet chuck.

WITH STOCK ON THE PIN, bolt the jig to the table and drill a hole through the circle's edge. Raise the bit for a $\frac{1}{8}$ "-deep cut, lock the spindle, and rotate the work clockwise.

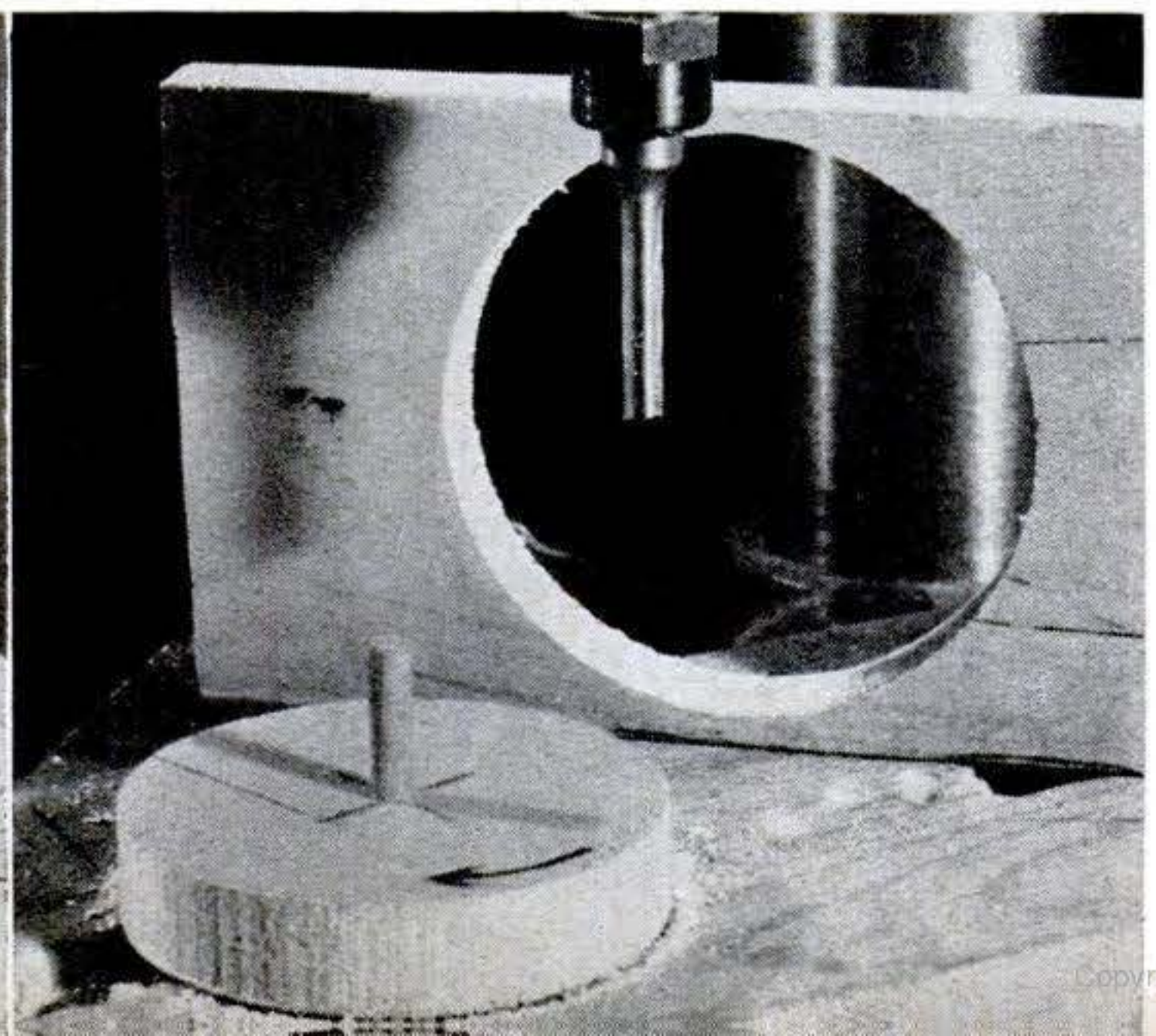
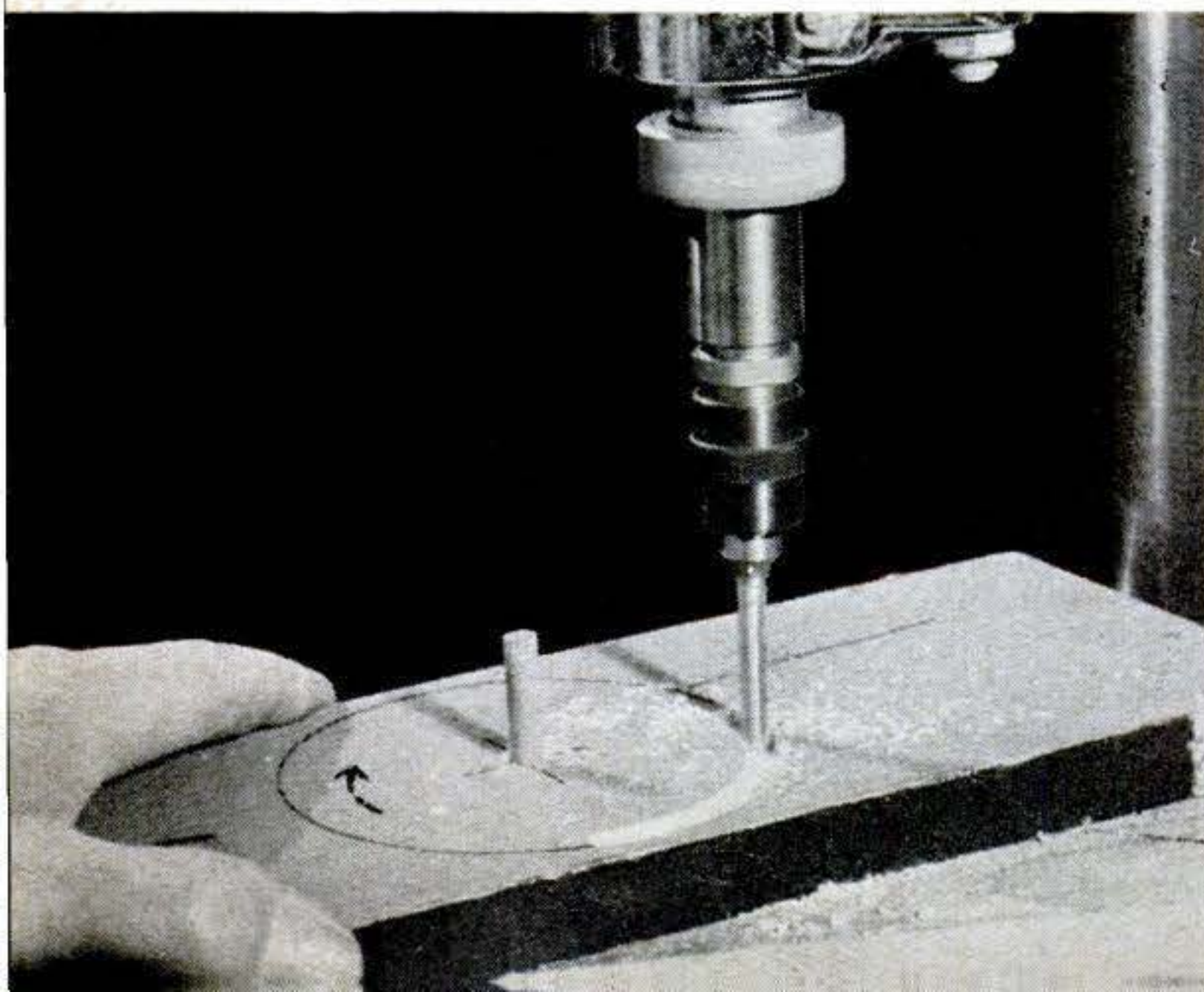

accept the fact that you are under-powered, and use a hand brace.

Drill-press rules. It's good practice, with most drill-press work, to clamp the stock securely to the table. Make it a must when boring any hole larger than $\frac{1}{2}$ ". Bear in mind that the speed and power of the driving unit—and this goes for portable drills, too—influence the performance of the cutting tool.

More power and less speed are required for large holes than small ones. When drilling any hole over $\frac{1}{2}$ ", start at the slowest driving speed, regardless of the bit or cutter you use. Increase the speed gradually to a point where the tool is cutting continuously and cleanly, without smoking, under moderate quill pressure. You can keep comfortably close, on a drill press, by belt changing. With a portable you can't. You'll have to control the feed pressure, instead.

Using hole cutters. These tools have larger capacities than conventional bits and are divided into two categories—one-sided cutters (the fly type), and multiple cutters, such as hole saws, spur bits and double-spur bits. The first are more likely to dig in and jam if you try to make them cut too much by forcing the feed. Generally they are not well adapted for use in portable drills because they must be backed with plenty of torque to core out large areas.

Your best bet for drilling big holes with a portable drill is a multiple cutter—preferably a rotary saw, which removes a minimum of material.

MAKE SUCCESSIVELY DEEPER CUTS until the coring operation is complete. If you want to make a disk with this method, set up the jig so the bit cuts *outside* the guide line. **END**



Planning to build? Nature can give you a moneysaving answer to this big question:

Which Direction Should Your New House Face?

By John L. Springer

HOW you mate your new house to the building lot is a decision that hits right at the pocketbook. Bad judgment can cost you a few thousand unnecessary dollars both in immediate construction and in a succession of heating, lighting and cooling bills that you will have to pay through the seasons.

You can save those thousands. Put nature to work. Most of the day the sun is in the south. In the early morning it shines in the east; in late afternoon in the

Next month: 10 Common Mistakes in Planning a House are discussed by architects. They tell you how to recognize and avoid building blunders that can cost you money and cause unhappy afterthoughts.

Use nature's aids to make your house a better home

Take a look at the land you're planning to build on. It may offer many ways of cutting construction costs and creating better living for yourself and your family—if you know how to take advantage of them. Here's a checklist that will help you—and nature—plan your home.



Winter sun riding low in the south can help heat your house if you invite it in.

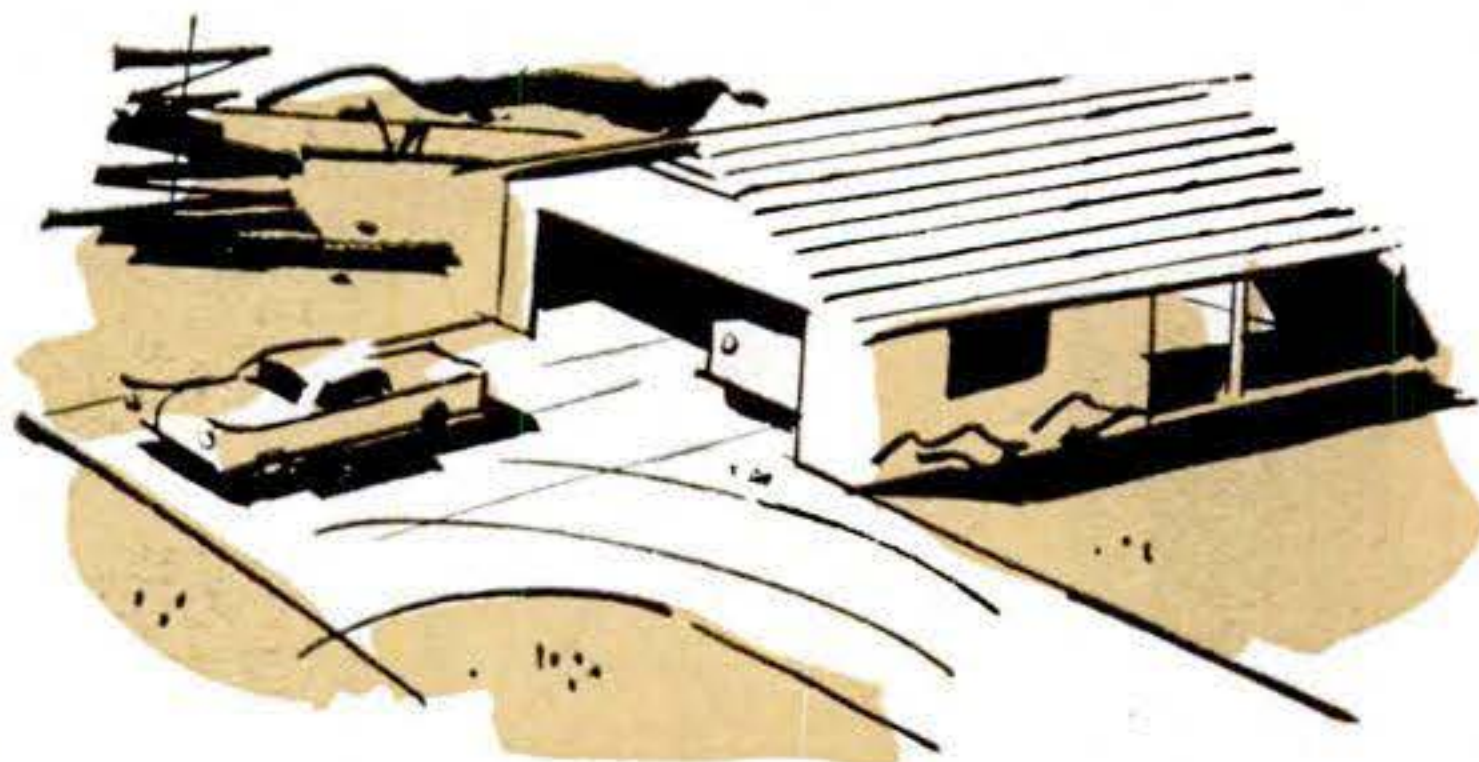

Beware of ambitious driveways. A side approach needs extra paving at the turn.



Place picture window not only for sun, but to have a view you won't get tired of.

west. In summer it's mostly high overhead; in winter, usually low-hanging. In most parts of the United States, prevailing winds come from the west and north. Your cue is to turn these facts of nature to your own advantage by the way you position the house on the lot.

It is not generally realized that most communities will allow you to turn a house any way you please. Of course, zoning laws require it to be a certain distance from the street, and from the sides and rear line of the lot. But you usually can locate the house at an angle, turn it so its side faces the street, and even put the entrance at the back.

Heating. If you place your house so most of your big windows face north or west, your furnace will work overtime to offset those frigid winds. That's because glass—even double-layer glass with an insulation space between—does not keep out the cold as well as a solid wall. An east window lets the sun in only early in the morning. The rest of the day it leaks house heat to the outdoors.

But if you put your big windows on the south, they will be on the protected side—away from the prevailing cold winds—and they also will let the sun in to do a heating job in winter. In fact, the sun's

heat alone could warm your house on clear, cold days. Tests have proved that in all but the coldest sections of the country—up near the Canadian border—windows on the south let in more heat on sunny days in winter than they let out. And you can cut your heating bills further by covering windows with heavy drapes. Open them in the morning to let light and sun in, close them at night to hold the warmth.

Cooling. During the summer the trick is to keep out the sun you've been inviting in through your south windows all winter. Otherwise your home will be a hothouse—or you'll need a big cooling plant and plenty of costly electricity to keep it comfortable.

Since the summer sun is high in the heavens, a wide roof overhang will shade the windows and keep you cooler. The overhang won't keep out your free heat in winter, because then the sun shoots in at a lower angle.

If there are big trees on your lot and you can place the house east of them, they'll be a cooling barrier between you and the sun. As the sun sinks on summer afternoons, aiming its rays almost on a horizontal line through your western windows, even roof overhangs don't help

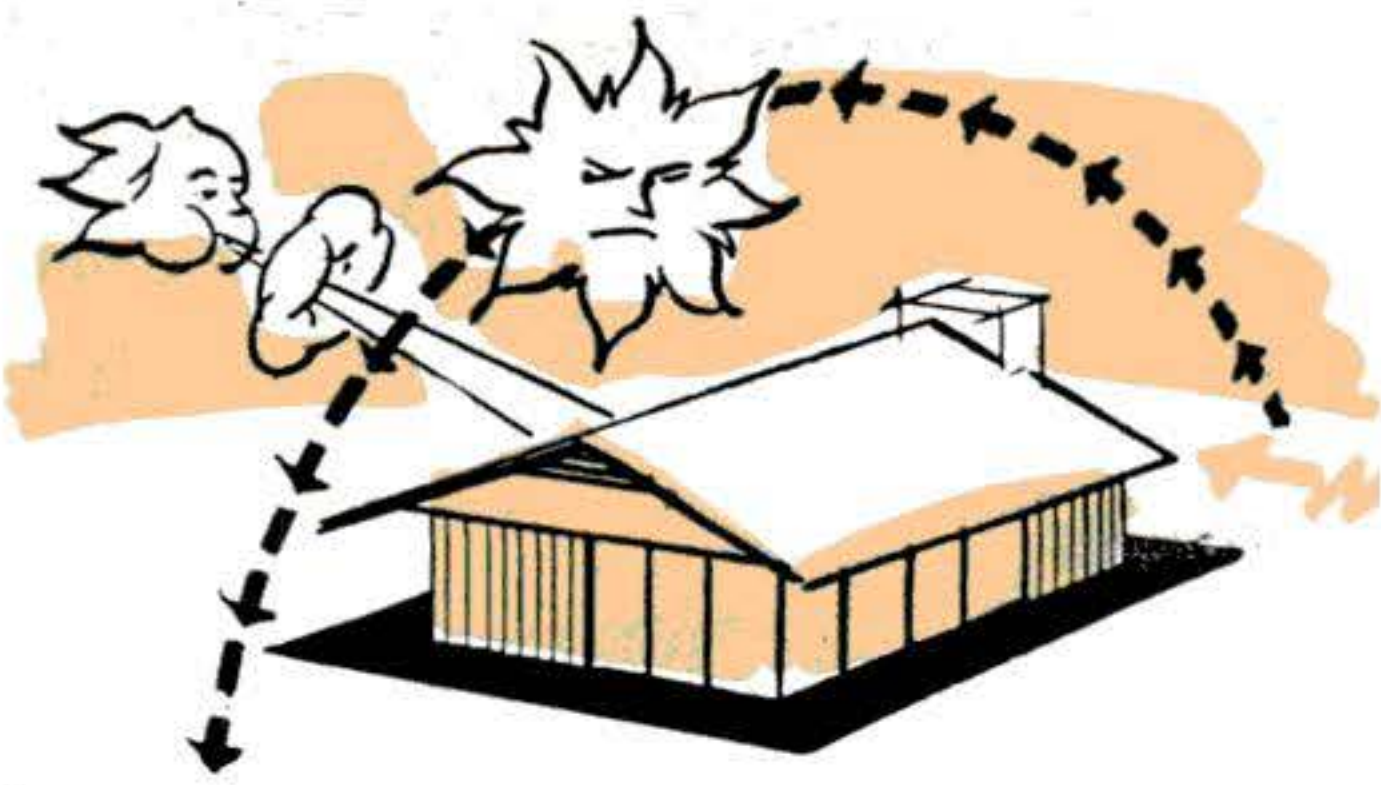

Roof overhang shades high summer sun. Trees help. Louvers let in cool breezes.



Ditch-digging is expensive. Locating near well, water main, sewer saves money.

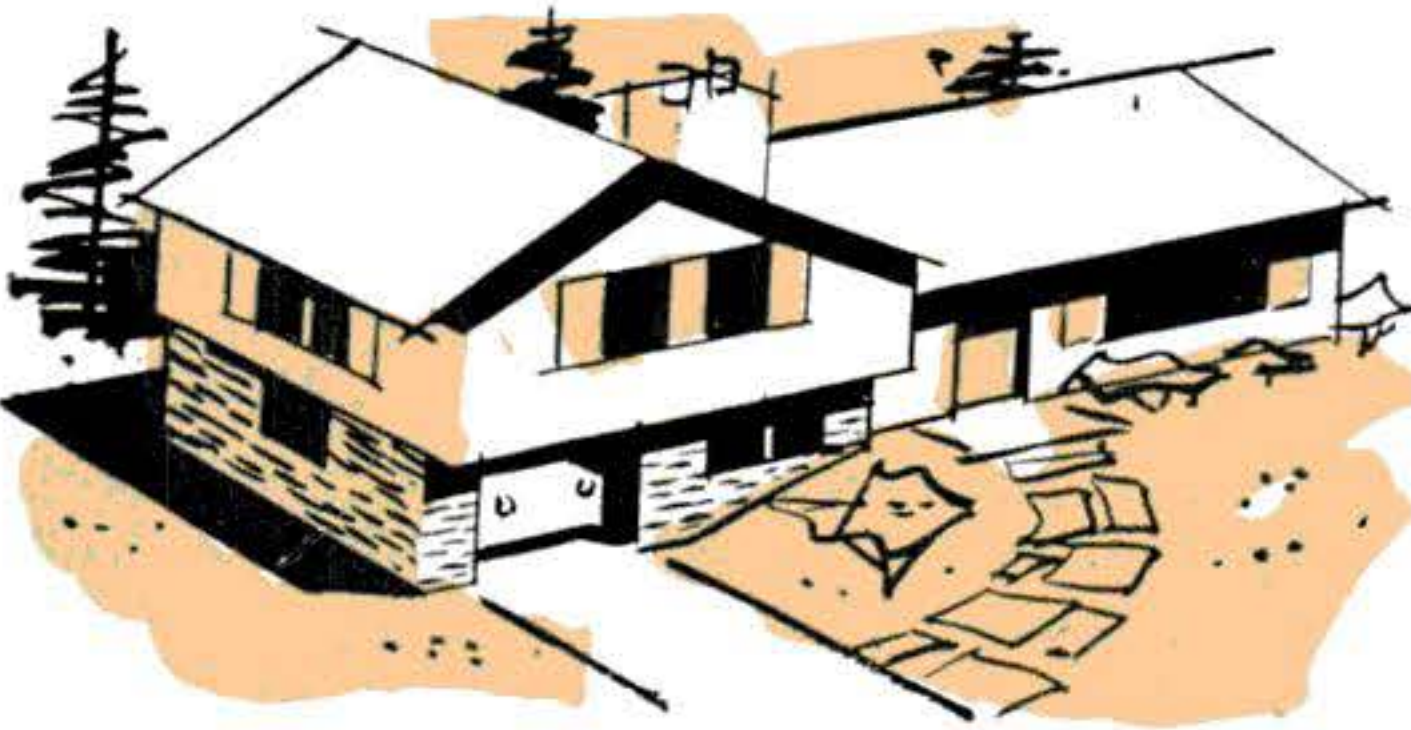

A house that uses a slope will eliminate costly earth-moving; retaining walls.



A southern-exposure kitchen will get free sunlight, cutting down electric bills.

much. But trees in full leaf create shade that will keep an air-conditioner snoozing during hot spells. Then, come autumn, the trees shed their leaves, just when you want all the help the sun can give.

If you can locate your house so its roof is shaded by trees too, extra summer cooling is the bonus. Since heat rises, the cooler your attic the more likely that warm air from below will rise into it, lowering the mercury downstairs.

In summer, too, you'd like to take advantage of breezes from the north. But say you've placed the house so that few or no windows face north, with winter in mind. How do you get those summer breezes? One way: Put oversize louvers in the north and west walls of the attic. Open the louvers all the way in summer for an attic "airwash" that will help cool the rooms below. In winter, close the louvers, but make sure the attic has enough air circulation to prevent winter condensation.

Air-conditioning engineers take locations of windows and trees into consideration when deciding how big a cooling plant should be. Letting nature help cool a house, they say, saves both on the cost of the original equipment and the cost of operating it, year after year.

Lighting. You don't need a flood of natural light in your bedrooms. Most families don't use their living room a great deal by day, either. But the kitchen, laundry area and dinette can use daylight as long as the sun will provide it. You can save on utility bills by putting these rooms on the south side where the sun will give them extra hours of free light.

Lower construction bills can result, too, from the way you set the house. Here are examples:

- **Plumbing.** In estimating the cost of water-supply and waste-disposal lines, plumbers figure the length of pipe run from the well or main water line and the sewer to your house. On a big lot, a few hundred dollars may be saved by building close to the main lines to eliminate long pipe runs. Even on an ordinary lot, you can save if all the water-consuming rooms—kitchen, bathroom, laundry—are on the side nearest the sewer.

- **Driveway.** With paving costs anywhere from 25 to 50 cents a square foot, the length of your driveway should be reckoned when you consider where you'll put the carport or garage. Obviously, the nearer the street the lower the cost. This is more of a factor if you have a big lot

3 ways nature can help you save money

- 1.** By letting the sun and winds coddle you, chopping sizable chunks off your bills for heating, lighting and cooling throughout the seasons.
- 2.** By locating the house—with due respect to local zoning rules, which you'll want to check—as close as possible to water source and sewage lines.
- 3.** By selecting your house design to fit the land, reducing the need for excessive earth-moving, for retaining walls and other money-gobbling projects.

instead of the usual suburban subdivision where most garages are the same distance from the street. Even so, a side approach, with a paved turn-around area, may easily add \$200 to the cost.

- Terrace or patio. How you locate these will determine whether you need an expensive roof to block the sun and keep you cool on hot days, or whether you let your house furnish the shade. The best patio location for both comfort and low cost is the north, where it will be in the house shadows most of the day and will be swept by cool northern breezes.

- Retaining walls. On some lots, if you put the house one way, a high wall is needed to separate the driveway from the lawn at a higher level; put the house the other way, and the lawn and driveway come together naturally. Figure a retaining wall at a dollar or more a square foot, and you'll agree that this could be an expensive item.

- Earth-moving. Here's another consideration. Houses built on concrete slabs need a level surface on which to lay the floor. If it does not already exist, dirt must be added or taken away. Split-level houses and houses with partially excavated basements require a ground surface that's higher in one part of the lot than the other. If the natural slope isn't there, or if you don't take advantage of it, hundreds of yards of earth may have to be moved. With bulldozer operators collecting up to \$100 a day, that dirt's not cheap.

- Clearing trees. On a heavily wooded lot you can easily spend hundreds of dollars to cut down and cart away tall trees. Remember that trees shade the summer sun and deflect winter winds. Save as

many as you can—why plant others after the house is built?

Plan or land—which comes first if you want the best possible combination of house and lot? There has always been an argument about this, and like the chicken-or-the-egg controversy, it has two sides.

Before World War II, standard advice was to choose your house plan, then find a suitable lot. But since the postwar building boom used up most of the good plots in many parts of the country, lot buyers can't be too choosy. Good building plots are harder to find now than good house designs to fit the problem sites that remain.

If you go shopping for a lot first, your best bet is one that slopes to the south. You can put big windows in the back of your house, where they'll get heat from the sun and you'll have a view of your own grounds. And, since cool air descends, you'll be in the path of breezes sweeping down from above.

When you try to fit your house to your lot (or vice versa) you probably won't be able to take advantage of all the money-saving opportunities in ideal house placement. You may have to make compromises. Surveys show, for example, that most women prefer a southside kitchen for sun and natural working light. But they also want the kitchen in the rear, so unexpected guests won't see the dirty dishes. If the rear of your lot is on the north, you'll have to choose between saving money and saving face—or buy an automatic dishwasher.

Even some of these ideas, however, can build more comfort into your home—at savings in the long run that may almost pay for the lot itself. END

Now, Make Your Own Book of Home Repairs

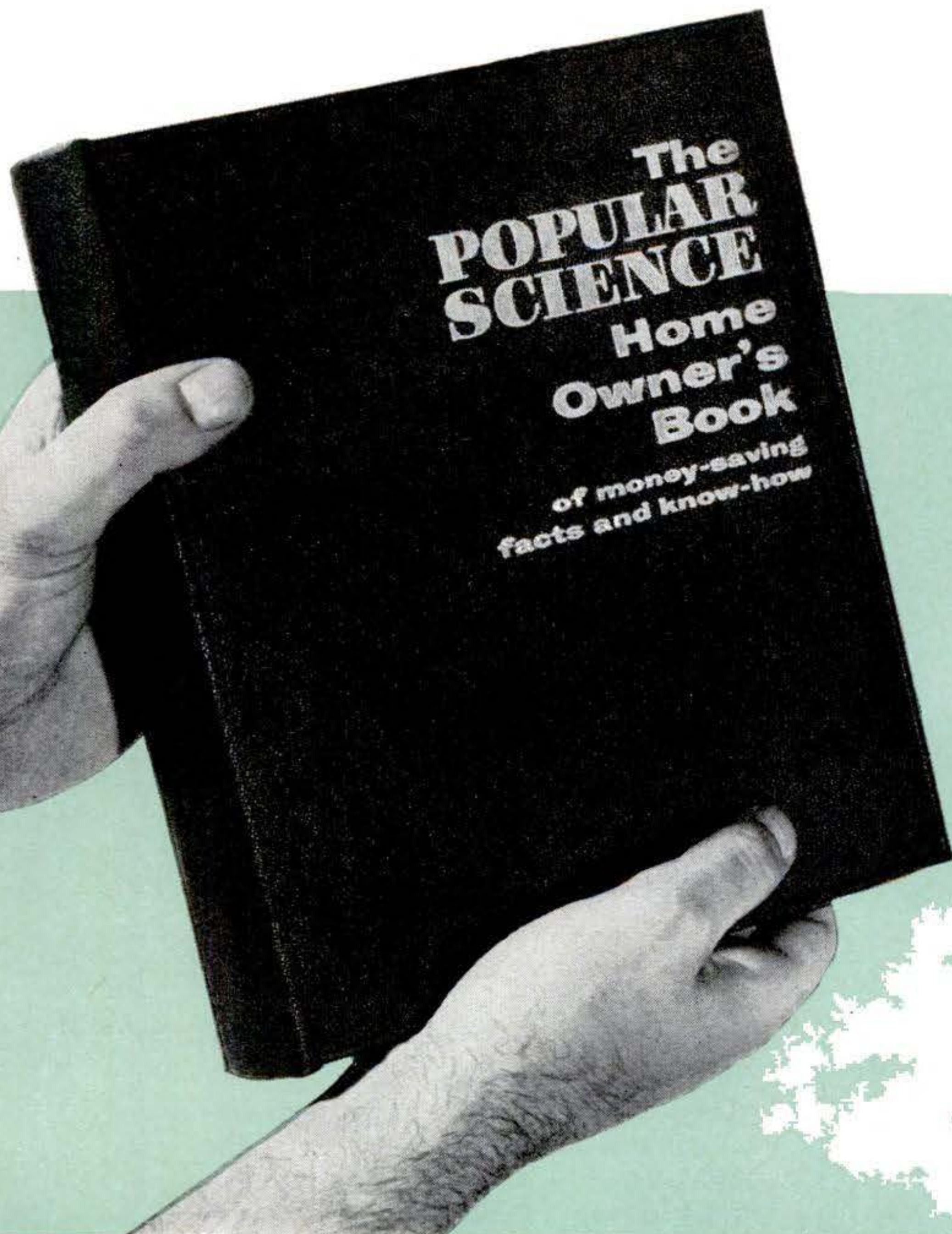

Big new
service
section
on next
8 pages

- know-how file
- fix-it file
- materials file

FACED with an unexpected job around the house, all of us sometimes think: "I read something about that once—wish I could lay my hands on it."

From now on, you can.

Three departments in this issue of POPULAR SCIENCE (they'll appear every month hereafter) provide facts you need—in a form easy to tear out and save *until* you need them:

The *Fix-it File* each month will tell how to handle a particular repair or maintenance operation.

The *Know-How File* will show in pic-

tures and words some specific technique useful in a variety of jobs.

The *Materials File* will report on items and equipment you may need tomorrow—or two years from now.

Save your guides in any looseleaf binder you have on hand.

Or you can get the special binder shown above, postage paid, by sending \$2.50 and your name and address to:

Magazine Services, Inc.
Dept. B-758
104 East 26th Street
New York 10, N. Y.

Cutting Glass Like an Expert

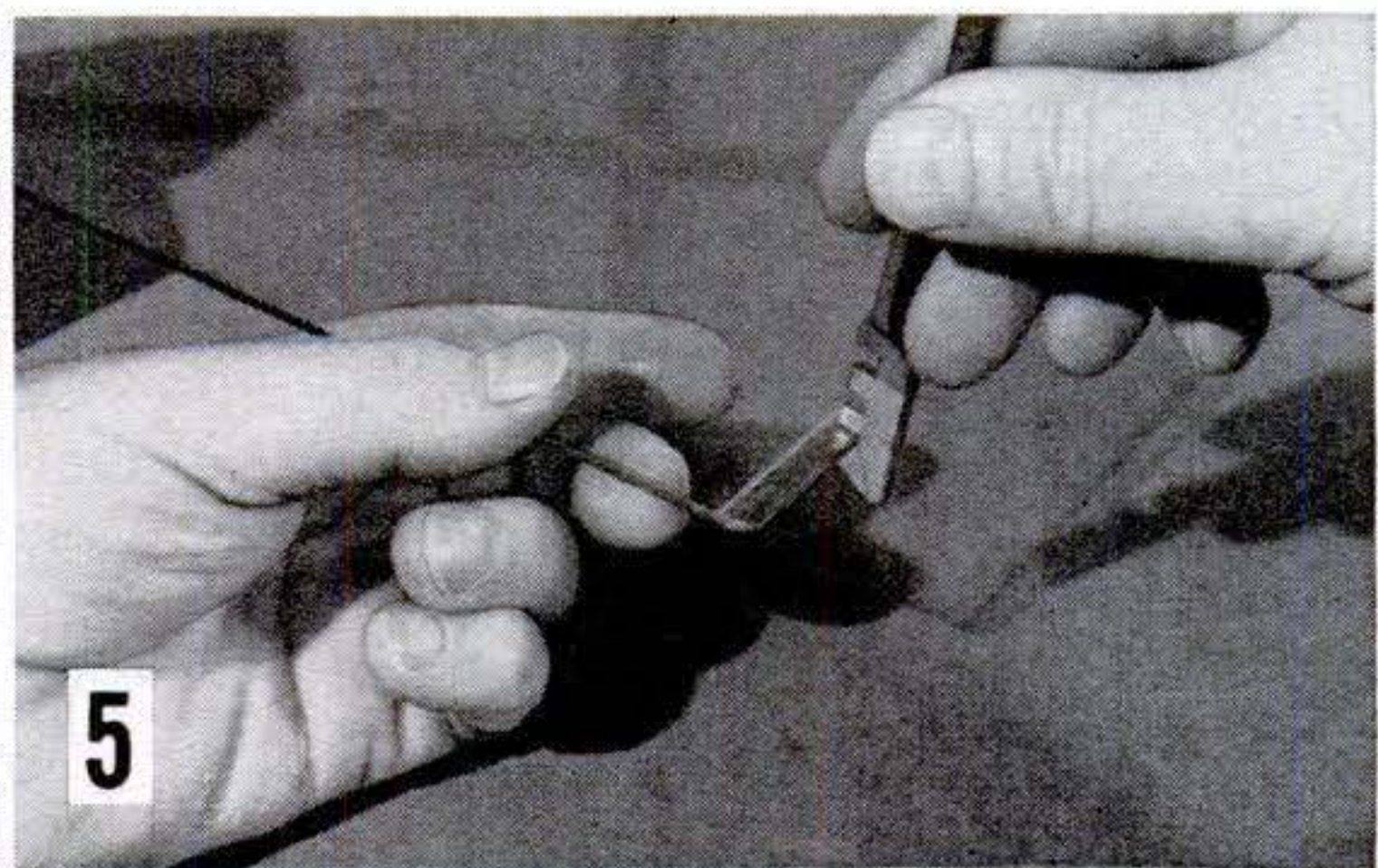
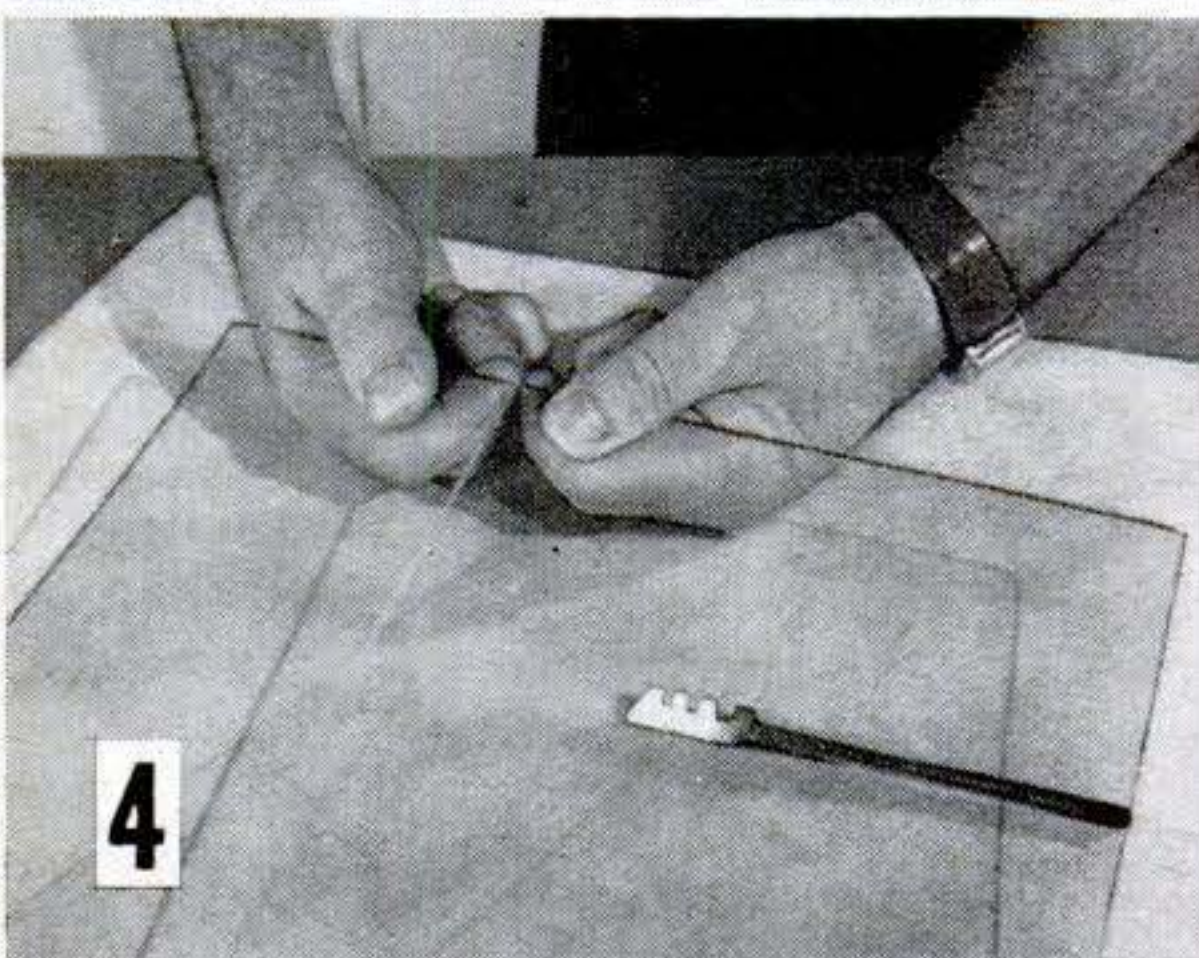
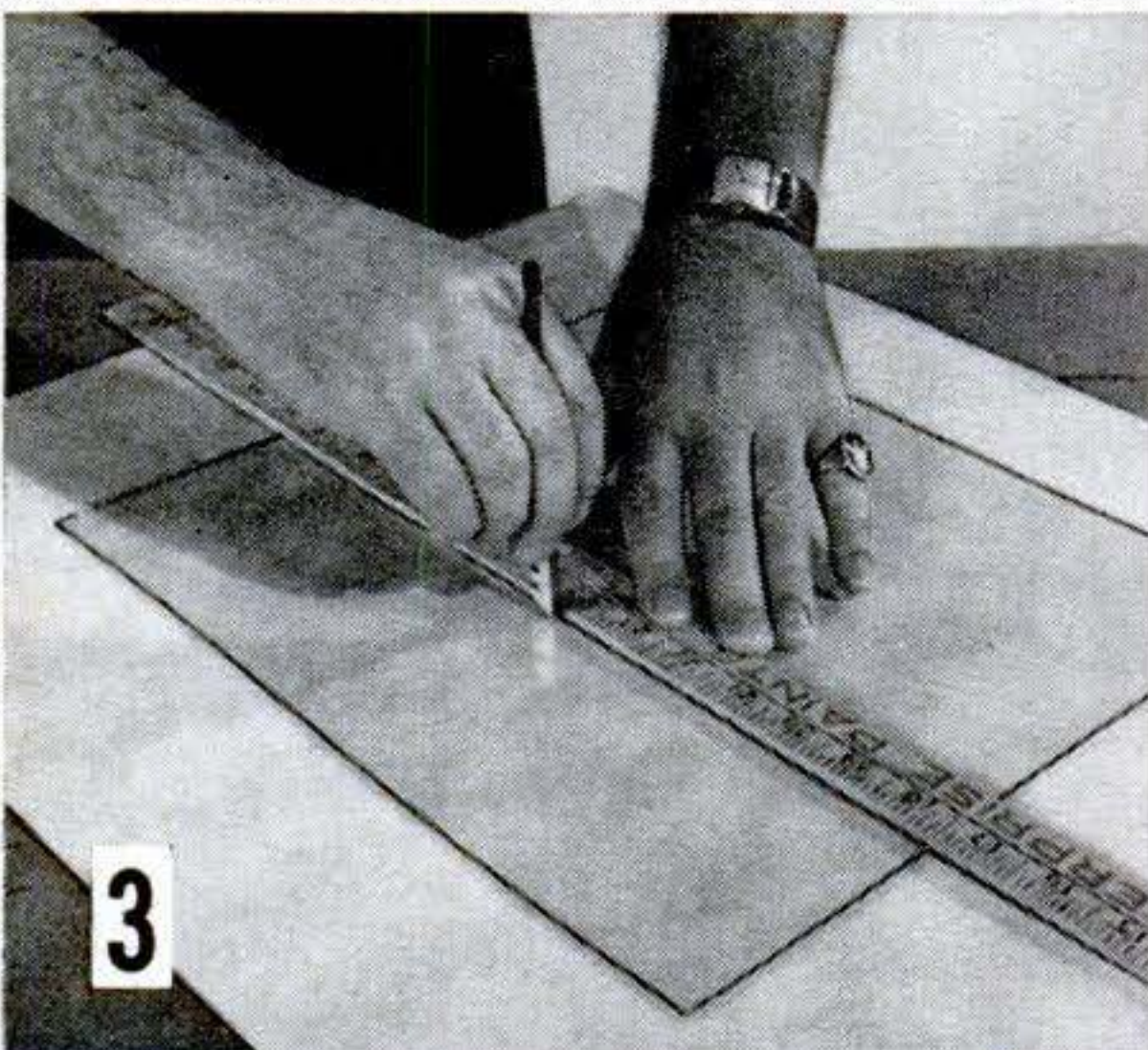
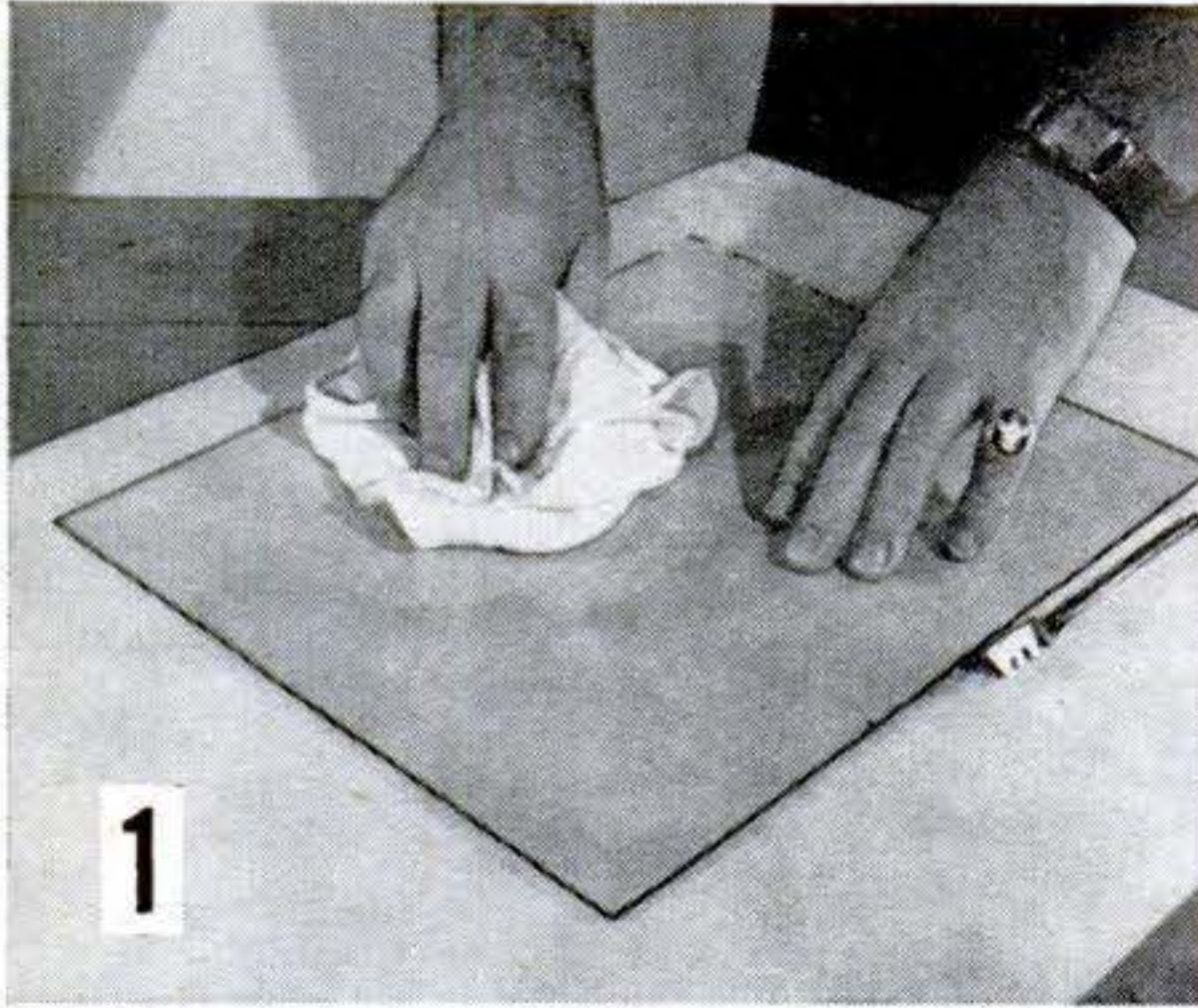

CUTTING glass is as easy as it looks if you follow the rules. You don't have to make a deep cut; a fine line will do. The sound of tearing silk as you make the cut is a sign that all's well.

You need a sharp cutter, of course, and a flat work surface. Rest the glass on layers of newspaper, felt or perhaps a blotter. Wipe away all dirt and grit (Photo 1 at left) that might dull the cutter or cause an imperfect cut, then lubricate the cutter wheel (2) with household oil, blotting off the excess. A free-running wheel stays sharp longer and won't jam or skip. Guide the cut with a wooden yardstick (3), dampening the underside or applying masking tape to keep it from slipping on the glass. Grip the cutter between the first and second fingers, with the thumb on the underside, and be sure to hold it vertically, never at an angle. Lower the cutter to the glass just short of the far edge and draw it toward you with an easy, continuous stroke. Use gentle but firm pressure. Never go over a cut twice.

Holding the glass firmly on both sides of the cut (4), break it with a quick down-bend motion. Some workers first gently tap the underside of the cut with the handle end of the cutter to crack the glass. Use the slots in the cutter to break off narrow strips (5). If a strip does not break cleanly, use the slots to nibble off short pieces. Practice on scrap glass.

If glass edges will be exposed in use, it's customary to smooth them on a wet grindstone. Lacking that, rub them on an oilstone soaked in water.

Doorbells and Chimes

BELL CIRCUITS

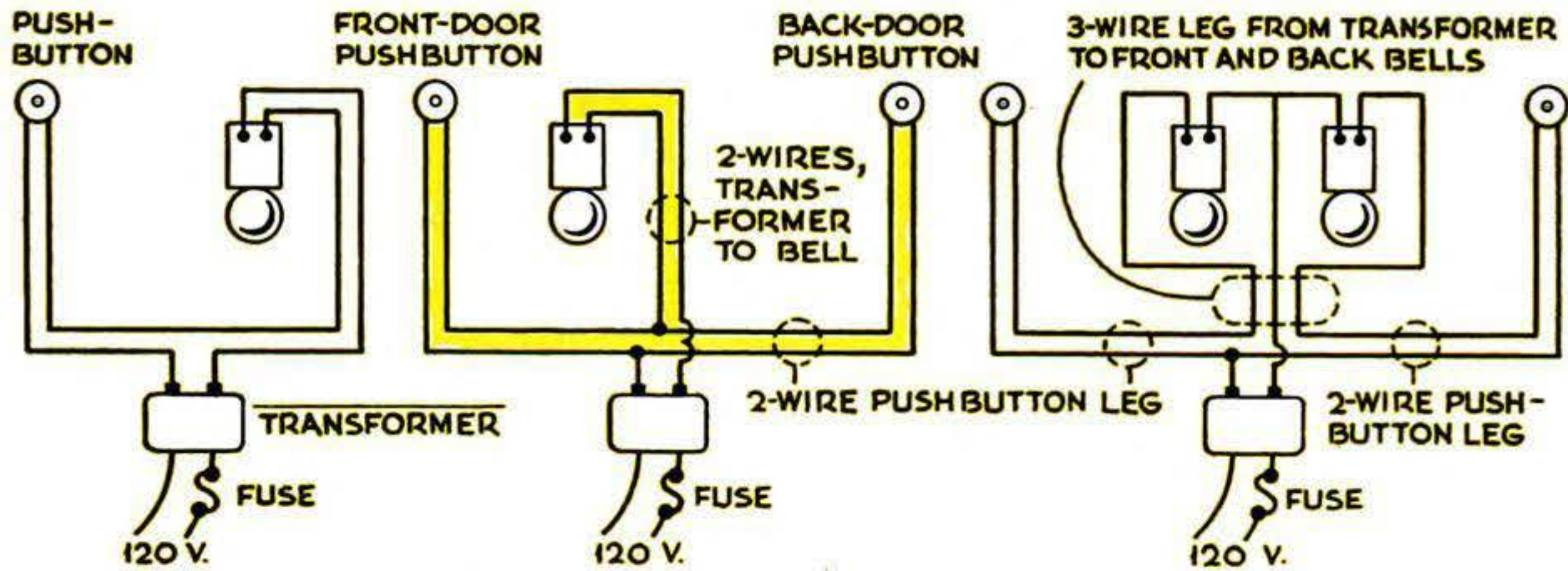

THE CIRCUIT for your doorbell or chimes is probably among the three typical ones sketched above. To troubleshoot your circuit you'll find the test equipment at the right helpful—a test lamp and a jumper wire. The test lamp is a series-type Christmas-tree bulb and socket; the jumper wire is a piece of insulated wire with safety pins soldered on its ends to serve as contacts.

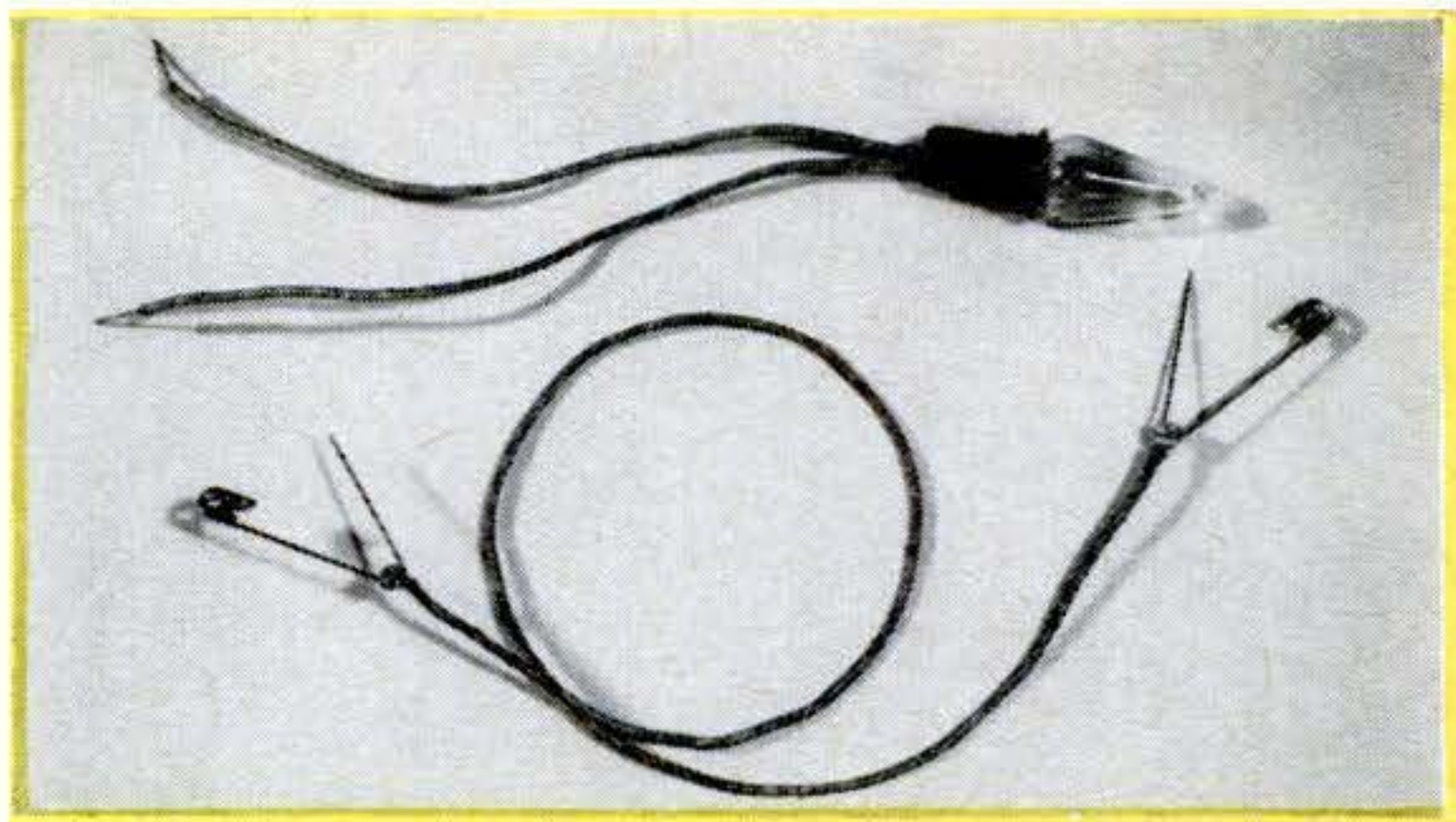

Symptom	Probable cause	To find trouble . . .
Bell dead	Pushbutton faulty	Short across button terminals
	Break in wires to pushbutton	Bridge wires with jumper
	Break in wires from transformer to bell	With button shorted, use test lamp at intervals along wire
	Short in circuit between transformer and bell	Make spark test at transformer with button shorted
	Transformer dead (burned out or fuse blown)	Use test lamp at transformer
Bell rings continuously; chime doesn't sound but plunger remains extended	Short in pushbutton leg of circuit	First be sure button isn't stuck. Then disconnect it. Snip wires in cellar or where they emerge from wall. If short is in wall use old wire to pull through new pair
Poor tone, or bell rings erratically	Dirt in mechanism	Clean with carbon tet or mount with gong down
	Burned points	File or sandpaper points
	Out of adjustment	Bend clapper, adjust chime
	Loose connection	Tighten all screw connections
	Pushbutton contacts dirty	Brighten with sandpaper
Two bell tones are difficult to distinguish	Improper installation	Use solder on one or slit one with hacksaw

What to do when the bell is dead

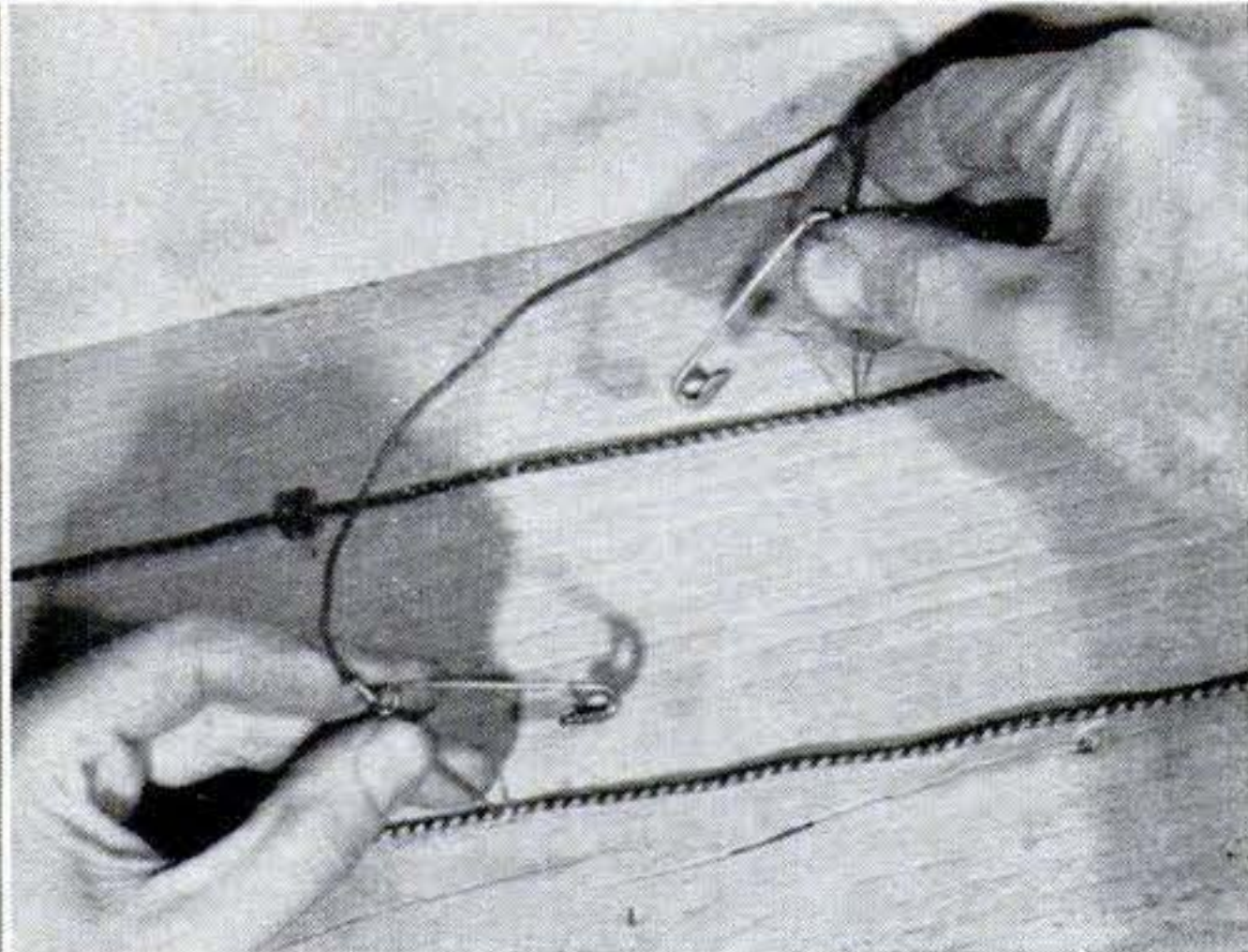
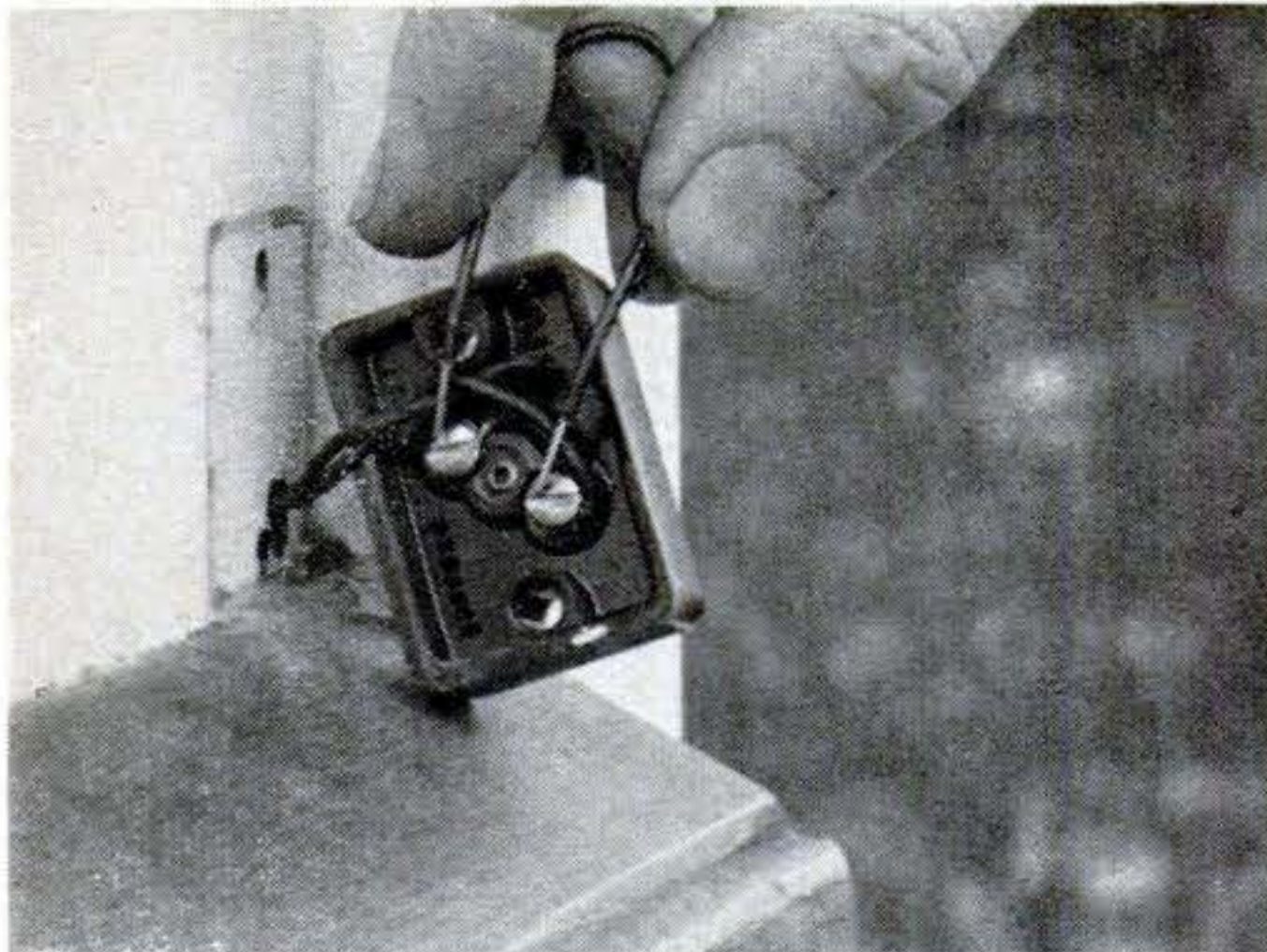

CHECK HOUSE FUSE FIRST. If okay, test transformer output by touching its leads with your test lamp. If lamp doesn't light, replace the transformer. Caution: *Remove* the line fuse before attempting to disconnect the transformer's 120-volt input leads. But if transformer is delivering, next bridge the button terminals with a wire (above left).

If this rings the bell, the button is at fault. If not, check continuity of the button wiring by piercing its insulation at several places with the pin-and-wire jumper (above right). Have someone push the button while you brush together one of the wires leading to the bell (below, left). A spark indicates that there is trouble at the bell.

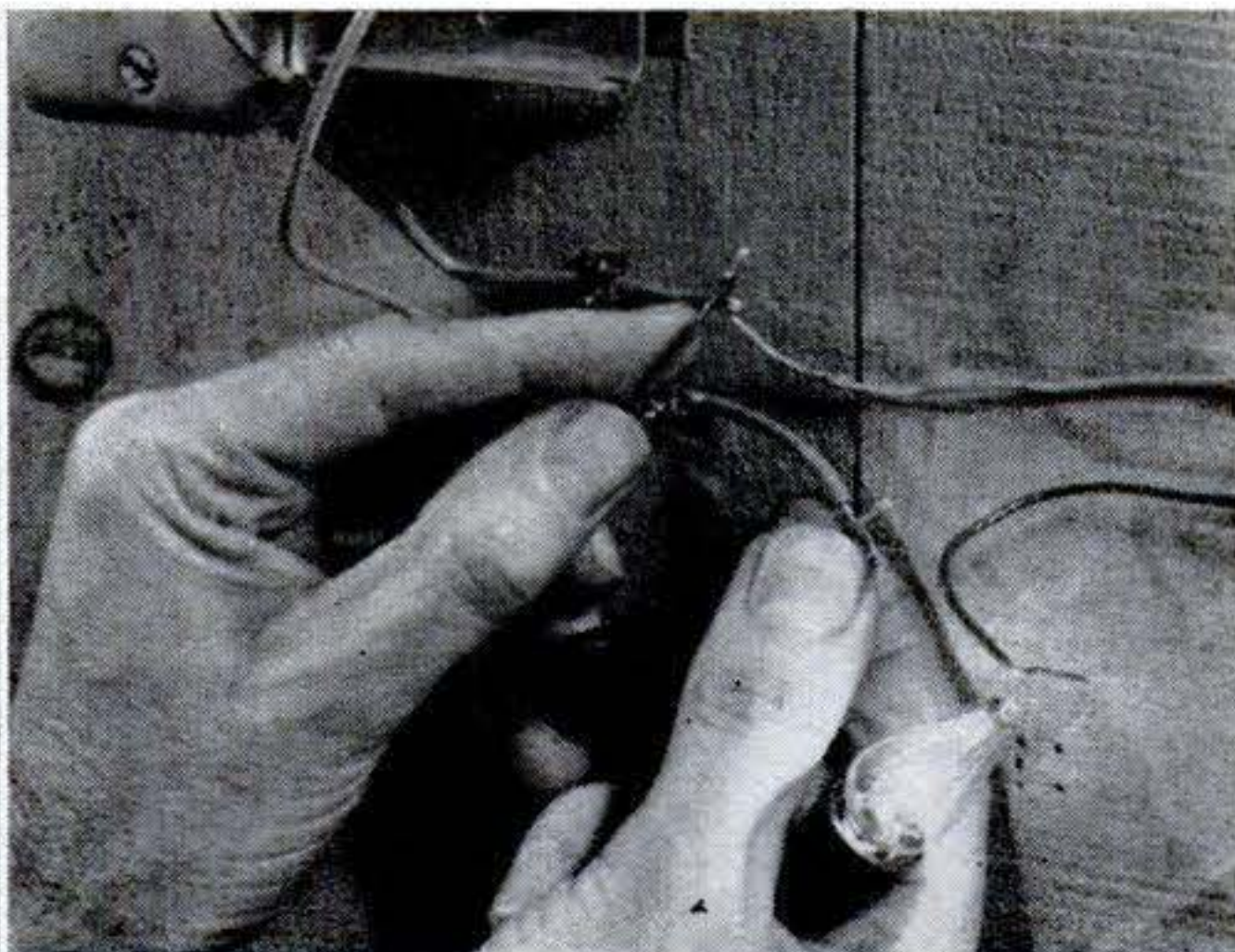
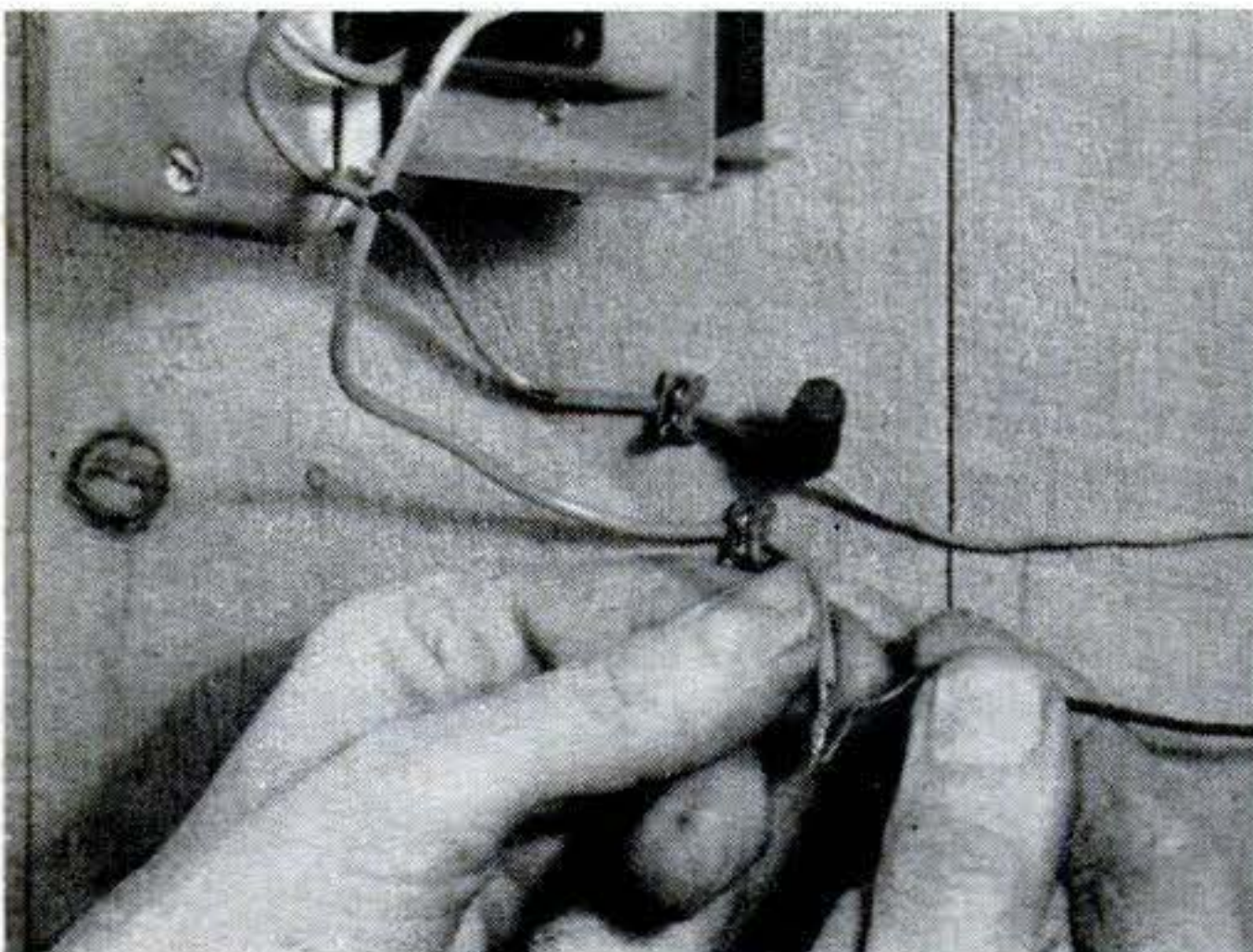

Cleaning and adjusting bells and chimes

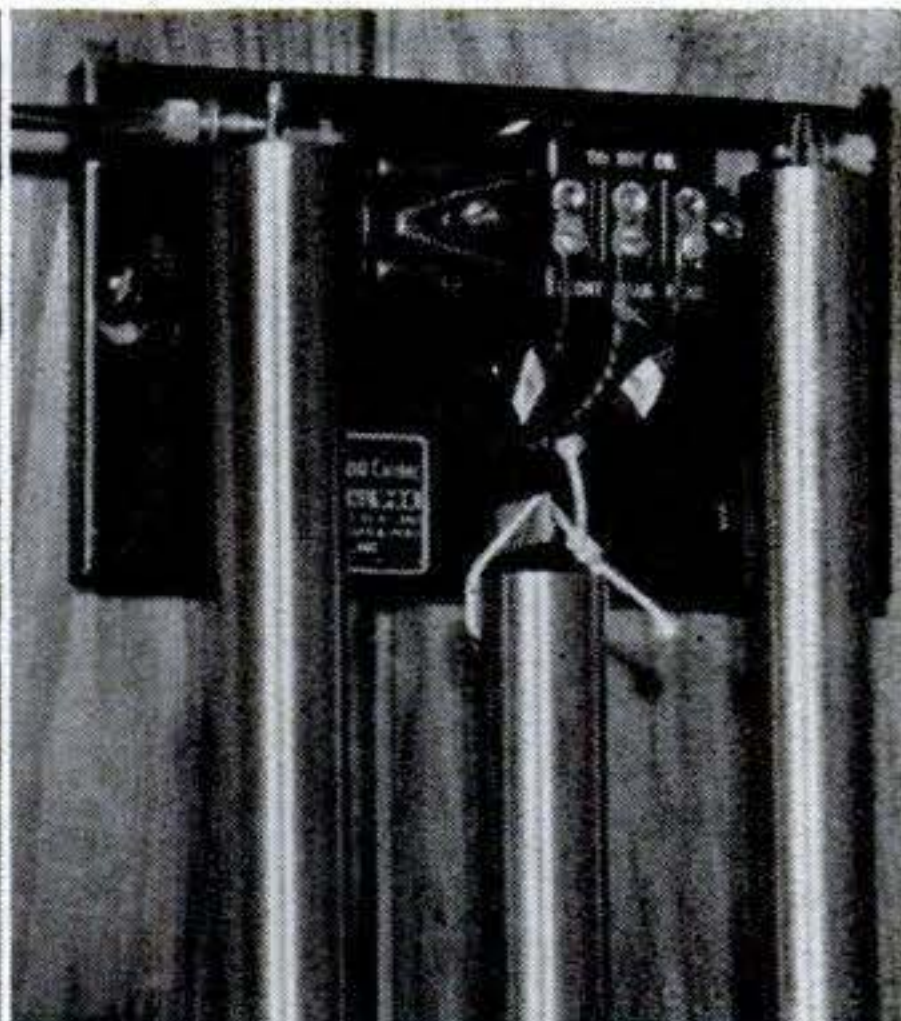
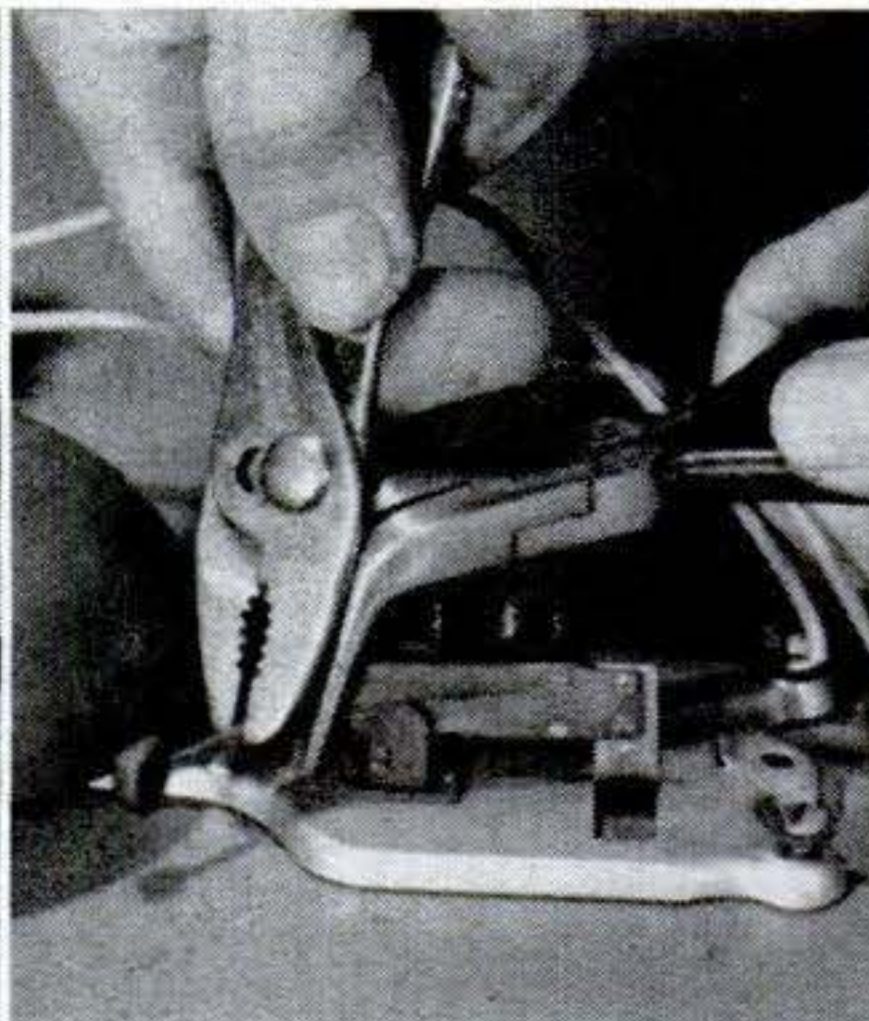

RUB FINE SANDPAPER between contact points to brighten them, then remove grit with a folded cloth. Bend clapper arm (center) so it strikes gong edge sharply. Mounting a balky bell upside-down will let gravity assist the clapper. Use a stiff brush to re-

move dust from chime mechanism; carbon tet for cooking-grease deposits. To adjust chimes, tap tube to make it vibrate, turn screw until tube touches plunger tip, then advance a quarter-turn more. If you take chimes down, number wires to avoid a mixup.



**materials
file**

The Basic Facts on Plastic Tile

PLASTIC tile offers you a modern way to cover walls. It's easy to install, inexpensive and easily maintained, and it comes in many sizes and shapes.

The squares, rectangles, triangles, L shapes, feature strips and trim pieces are all modular. This means that you can mix tiles of many shapes and sizes, yet have them fit together exactly.

Squares, for example, come in four sizes. You could fill an 8½"-square space with a single 8½" tile, four 4¼" tiles, sixteen 2⅛" tiles or sixty-four 1 1/16" tiles. By combining big and little tiles you can create an infinite variety of designs.

The best-quality plastic tile is slightly thicker than .062"—to comply with an industry standard. But tile

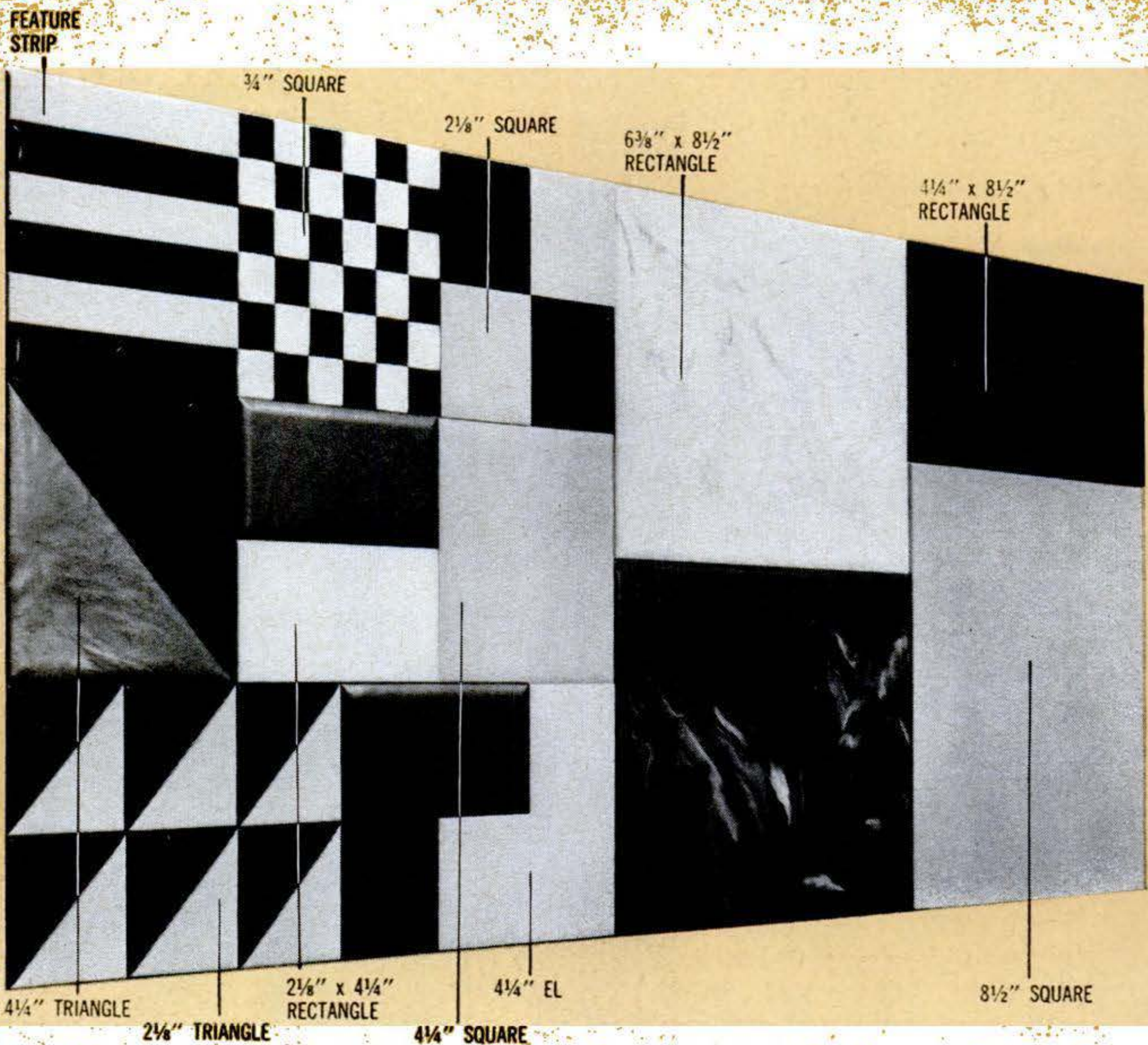

Plastic tile comes in fit-together sizes

ANY DESIGN IS POSSIBLE with the new modular plastic tile. It comes in squares, rectangles, triangles and "els." Each shape

is made in several sizes, dimensioned so you can mix big squares with small triangles, for example, and have them fit evenly.

only .050" thick can also be had. The lighter tile costs less but is less likely to form an even surface.

At latest count, there are 140 different colors or shades to choose from. In addition to a glossy surface, plastic tile comes with matte, granite-tone, marbleized, or metallic finishes. There are even fluted and quilted surfaces.

Advantages. Plastic tile can no longer be tabbed as the Johnny-come-lately imitator of ceramic tile. Despite a budget price tag, plastic tile has very desirable

qualities—easy cleaning, pure colors and light weight (six ounces per square foot). Most important is the weight. You can tote plastic tile home with you, and any wall or ceiling in the house will safely support it.

Where to use it. You can use plastic tile in the kitchen, laundry, storage room, foyer, halls, children's bedrooms and elsewhere. It's also a favorite choice for boats and mobile homes.

But don't use plastic tile outdoors or near sources of heat—it doesn't weather

You can use decorative plastic tile in any room of the house



KITCHEN



LIVING ROOM

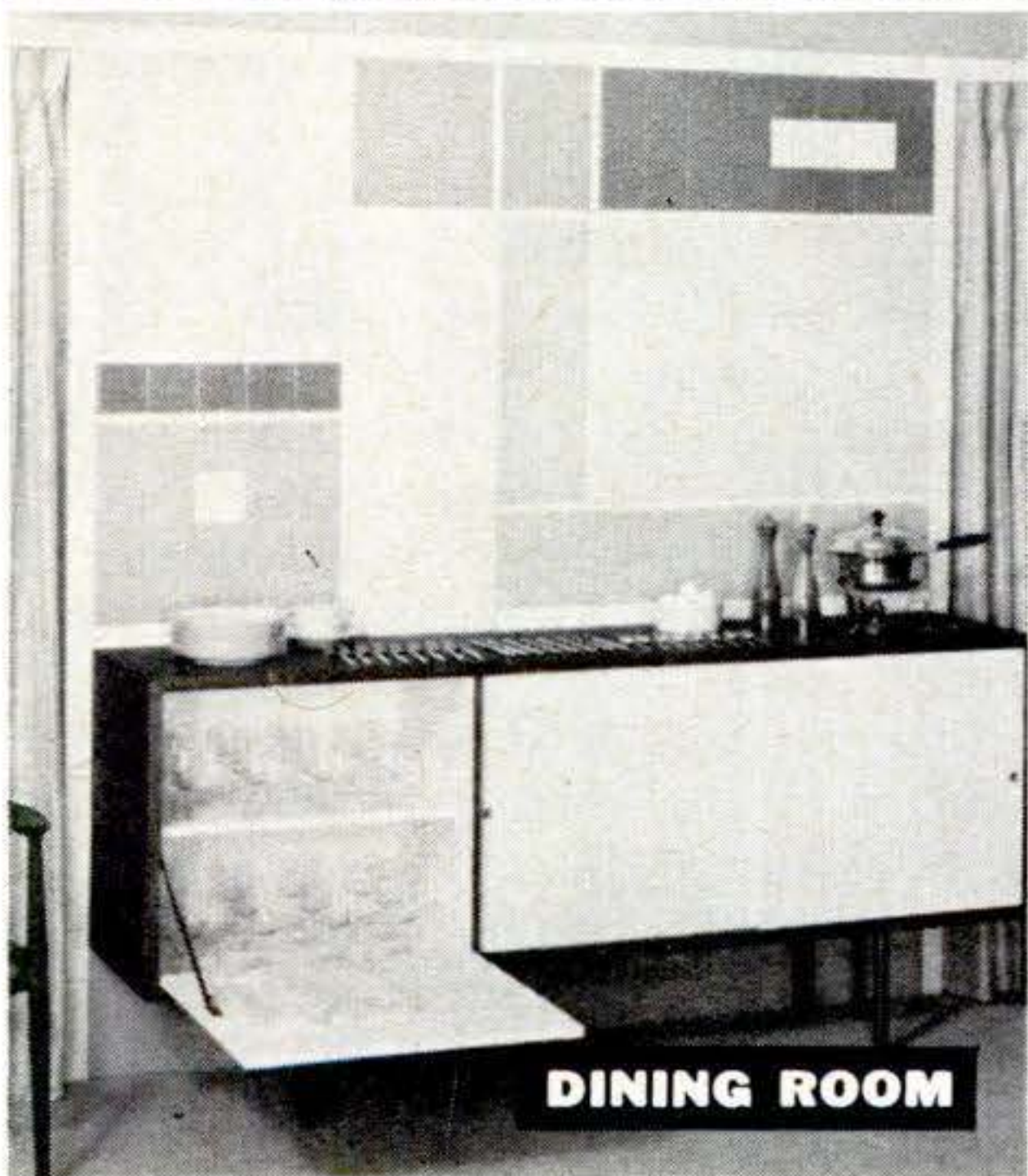

DINING ROOM



DEN

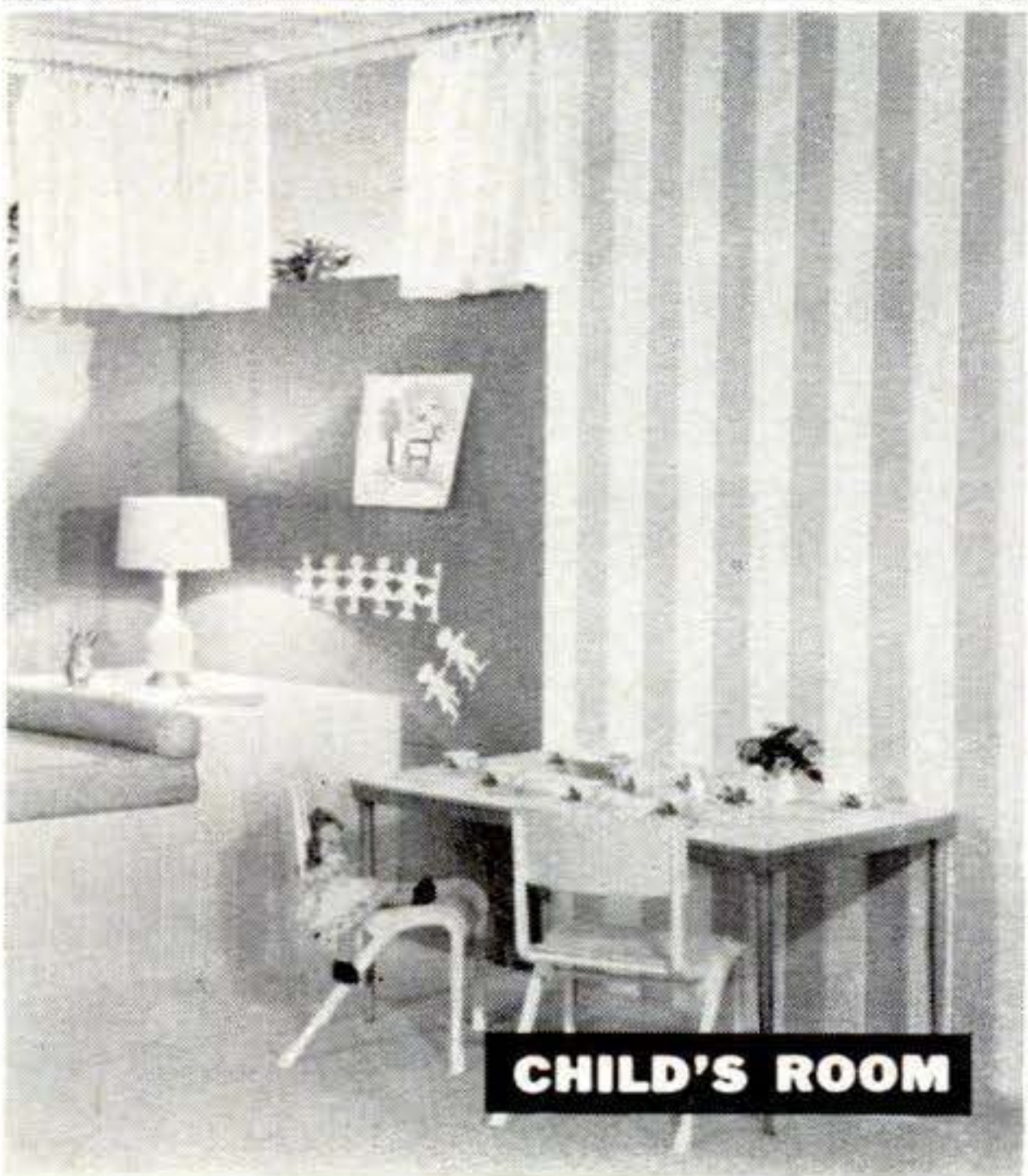

CHILD'S ROOM



LAUNDRY

well and can't take temperatures over 180 degrees. You can substitute metal tile (stainless steel, copper or aluminum) near radiators, counter-top burners or within three inches of light bulbs.

Heavy wear, abrasion and certain chemicals harm plastic tile, too. It will stand up under a direct hammer blow, but can be scratched quite easily. (In areas subject to damage from banging doors or kicks, as in the bottom row where wall meets floor, many pros use cove tile of rubber or an abrasion-resistant plastic.) Solvents such as turpentine, kerosene, nail-polish remover or oil paint will mar the finish.

What does it cost? You can buy some plastic tile for 35 cents a square foot or more, or pay as little as half that much. A special vinyl-plastic tile that looks like real marble runs as high as \$1.25 a square foot—but this is a luxury item to be used sparingly.

Quality causes the price difference in tile as in other materials. The best is made from virgin plastic pellets and costs at least 25 cents a square foot. Bypass cheap tile made from reprocessed scrap.

Buying tips. Price is a good guide for separating quality tile from cheap. But to make sure you get only the best, you should make these checks:

- Look for a seal or statement on the tile or package indicating conformance with commercial standard CS 168-50, U.S. Bureau of Standards. (Lack of a seal, however, doesn't necessarily indicate poor quality.)

- Feel the edges of the tile. They should be squared off somewhat, rather than knife-edged. Thin tile cracks easily and slips behind adjoining tile when you try to install it.

- Hold the tile to the light. If you can see your fingers clearly through the plastic, you will be able to see trowel marks too. Almost no light should come through.

- Examine the tile surface for scratches, fingermarks and embedded dirt. These indicate inferior plastic. When you buy tile, get some extras for possible use later. These matching replacements will come in handy in case you break an installed tile or move some fixture like a towel bar or light outlet.

(Replacing a damaged tile is simple, by the way. You punch a screwdriver or ice pick through the center, pull off the tile

and replace with a new one. Butter it first with mastic adhesive.)

Tips on applying tile. You can apply tile to any wall or ceiling that is smooth, dry and solidly built. Plaster, plywood, brick or concrete and any kind of wall-board will support it.

If a wall gives when you press on it you will have to do some reinforcing to make it rigid. High or low spots will need sanding or filling. Wallpaper and poorly bonded (or water-soluble) paint should be removed. Bad plaster must be patched with new plaster or plasterboard. And take down all removable fixtures.

Moisture is an enemy of any tile, plastic or ceramic. When vapor gets behind tile and condenses there, it rots the wall; eventually the tile fails, too. To prevent this, a waterproofing compound made for the purpose should be applied to the wall around bathtubs, wash basins, in shower stalls and laundry rooms.

Tile the ceiling before you tile adjacent walls. You can use the same method as for floor tile: Draw two guide lines at right angles to each other, intersecting in the center of the ceiling. Then begin tiling from the center and work outward, cutting the border tiles to make them fit. Ceiling tiles installed on a diagonal are especially attractive.

Besides tile you will need adhesive, a special trowel to spread it and a fine-toothed saw or a tile cutter. Mastic adhesive commonly comes in gallon cans that cost about \$3.50 and cover roughly 40 square feet. The trowel should have notches at least $\frac{1}{8}$ " deep and $\frac{3}{16}$ " apart; an average price is \$1. If you don't have a fine-toothed saw or tile cutter better get one—scissors, shears and knives leave nearly invisible hairline cracks that cause trouble later.

You can butt plastic tile if you like. Or, to make them resemble the ceramic kind, you can space them $\frac{1}{8}$ " apart or so and grout between by smoothing adhesive along the joints. At least one plastic-tile company offers "grout strips," slivers of white plastic $\frac{1}{8}$ " wide that can be pressed into joints. Held by the adhesive, they look like even grout lines.

Cleaning plastic tile is best done with a soft cloth dipped in cool water containing a small amount of liquid household detergent. Never use kitchen cleanser, steel wool or other abrasives.

You can get a full range of trim pieces in plastic, too

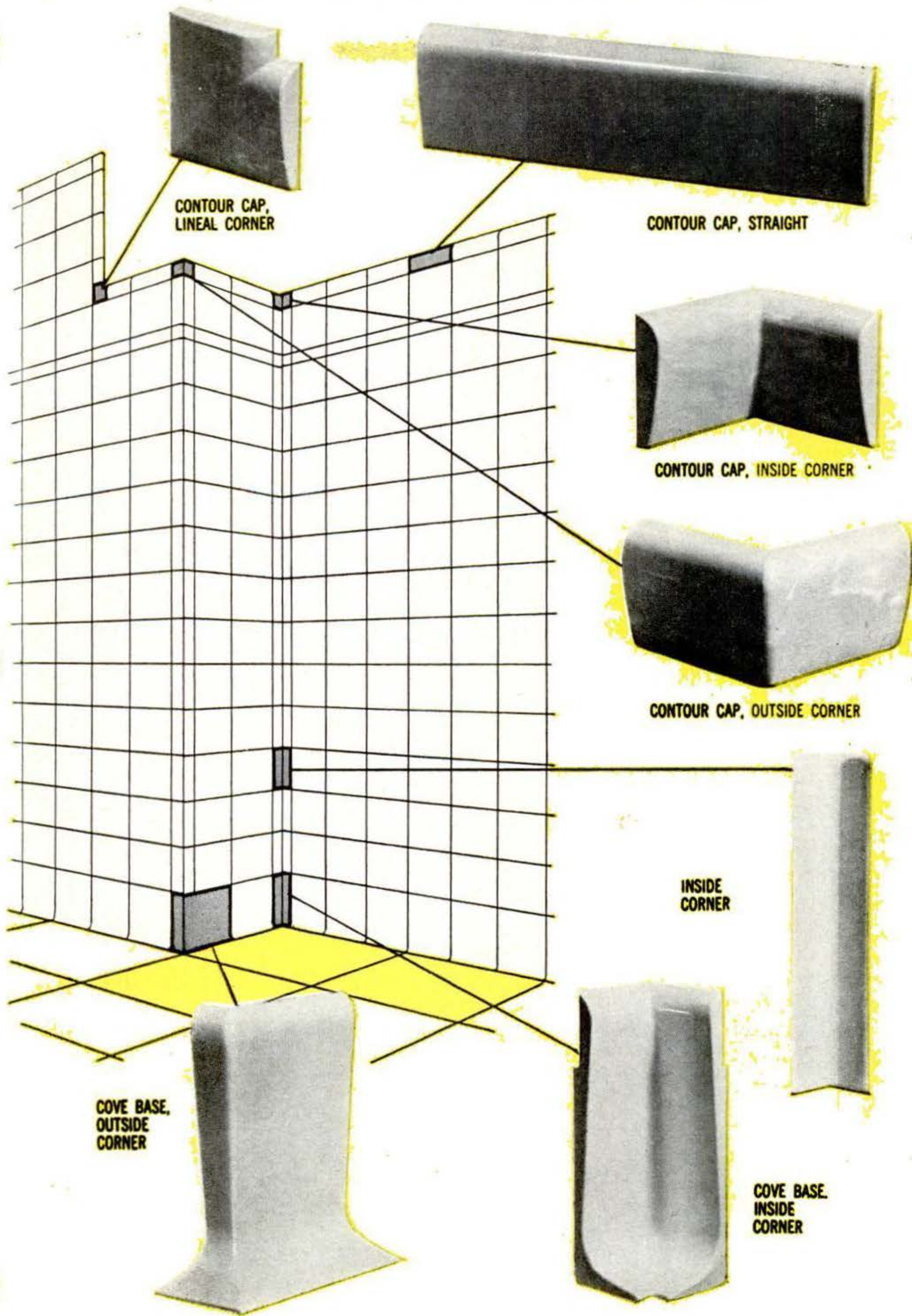

CONTOUR CAP,
LINEAL CORNER

CONTOUR CAP, STRAIGHT

CONTOUR CAP, INSIDE CORNER

CONTOUR CAP, OUTSIDE CORNER

INSIDE
CORNER

COVE BASE,
OUTSIDE
CORNER

COVE BASE,
INSIDE
CORNER

Tearing Out Pages for the Home Owner's Book

THREAD and a paper clip make an effective tool for removing magazine pages you want to save. The thread cuts

closer to the binding than any scissors. And it won't loosen other pages too, as a razor blade usually does.

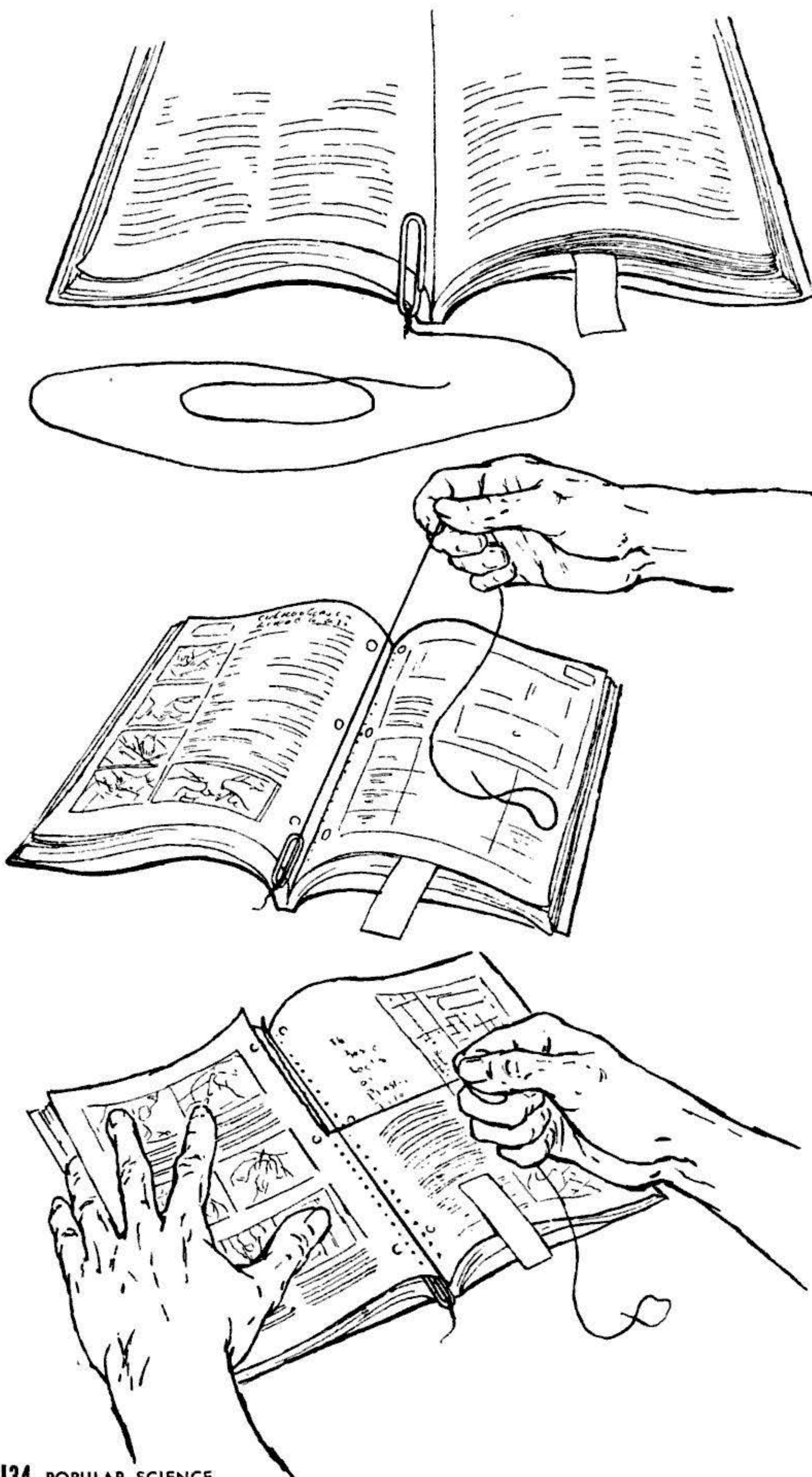

1 ANCHOR PAPER CLIP in the magazine by sliding it over a dozen or so pages, well beyond the page you want to remove. Let the clip stick out a bit while you tie a piece of thread on it that's twice the length of the magazine. Then shove the clip in tightly against the magazine's centerfold.

2 LAY THE THREAD in place along the centerfold, between the page you want to remove and the page following. Stretch the thread taut, pulling it tightly into the crease. Now turn the page that you've selected over onto the thread.

3 CUT THE PAGE FREE by pulling the thread while you hold the magazine open and flat. Pull slowly, keeping the thread roughly at right angles to the crease. It only takes a few practice tries, you'll find, to cut perfectly straight edges.

Buyer's Guide to the '58 Window Fans

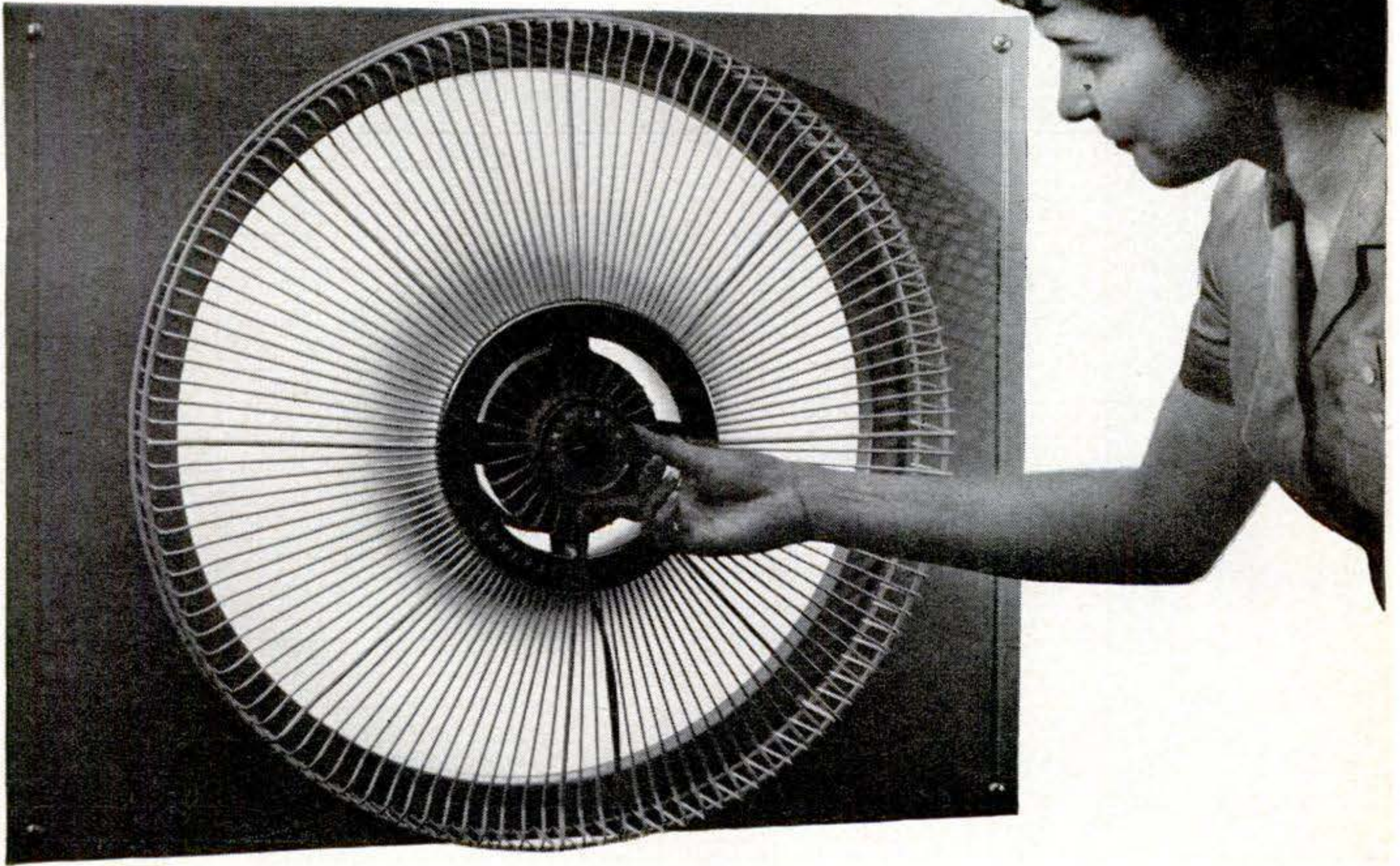

Picking the right size and capacity can be tricky. Here are the facts on getting the most cooling for your cash

By Ralph Treves

WINDOW fans have come a long way from the early wheezers. New slim, streamlined models have caused sales to soar from 320,000 in 1950 to more than 2½ million last year. Many of them have speed selectors, reversing switches to blow air either way, and built-in thermostats that turn them on and off while you sleep. All abound with glitter to attract the eye.

But—and here's the big point—a window fan's real job is still to move air. How much it moves will determine how cool you'll be. That's what you pay for—not the fancy trim.

Air-moving capacity is particularly im-

portant today because modern fans are used differently from their earlier predecessors. Instead of just circulating already-hot air *inside* a room, they're designed to fit in a window and exhaust hot, stagnant air *outside* a room.

As the hot air is pulled out, fresh outside air—up to 20 degrees cooler at night—is pulled in through other windows. The trouble here is that it takes a lot more capacity to pull air out a window than just to move it around inside.

That's why it pays to pick a fan carefully.

How big should it be? Fan capacity is measured by the number of cubic feet of air it will deliver every minute. In mild northern states, a complete change of room air once every three minutes is usual-

**Consumer
News**

The new WINDOW FANS:

MAKE	MODEL	LIST PRICE	BLADE SIZE (in.)	AIR-MOVING CAPACITY (cu. ft./min.)		MANUFACTURER'S MOTOR RATING	NUMBER OF SPEEDS	BUILT-IN THERMOSTAT?	REVERSING SWITCH?
				Exhaust	Circulating				
AIR KING	SQ-20-E	\$39.95	20	3,250	4,000	n.a.	2	yes	yes
	RA-20	\$39.95	20	3,250	4,000	n.a.	3	no	no
	20-R	\$49.95	20	3,250	4,000	n.a.	3	yes	yes
	SQ-20-PB	\$49.95	20	3,250	4,000	n.a.	3	yes	yes
	AV-16-E	\$54.95	16	2,000	2,460	n.a.	2	n.a.	yes
	FM-20	\$69.95	20	3,250	4,000	n.a.	3	n.a.	n.a.
	AV-20-PN	\$69.95	20	3,250	4,000	n.a.	3	yes	yes
BAR-BROOK	W-222	n.a.	22	n.a.	2,800	1/12 hp.	2	no	no
	RW-222	n.a.	22	n.a.	3,450	1/12 hp.	2	no	yes
	W-302	n.a.	30	n.a.	4,800	1/6 hp.	2	no	no
	RW-302	n.a.	30	n.a.	4,800	1/6 hp.	2	no	yes
CHELSEA	W-5	\$49.95	16	n.a.	2,500	1/11 hp.	n.a.	yes	yes
	B-3	\$49.95	20	n.a.	3,800	1/11 hp.	4	no	yes
	B-4	\$49.95	20	n.a.	3,800	1/11 hp.	n.a.	yes	yes
	W-1	\$49.95	20	n.a.	3,800	1/11 hp.	4	no	yes
	W-2	\$59.95	20	n.a.	3,800	1/11 hp.	n.a.	yes	yes
COOLAIRE	U-2016	n.a.	20	3,000	n.a.	1/6 hp.	2	no	no
DIEHL	Economy	n.a.	20	2,100	n.a.	n.a.	2	no	yes
	Airmaster	n.a.	20	2,100	4,000	n.a.	2	no	yes
	DeLuxe	n.a.	20	2,100	n.a.	n.a.	2	yes	yes
	Super	n.a.	24	3,600	n.a.	n.a.	2	no	yes
DOMINION	2056	\$29.95	20	n.a.	3,500	170 watts	2	no	no
	2064	\$34.95	20	n.a.	2,500	170 watts	2	no	yes
	2067	\$37.95	20	n.a.	3,500	175 watts	2	no	no
	2054	\$39.95	20	n.a.	3,500	200 watts	2	no	yes
	2053	\$42.95	20	n.a.	3,500	170 watts	2	no	no
	2066	\$43.95	20	n.a.	4,000	200 watts	2	yes	no
	2055	\$44.95	Twin 12	n.a.	2,500	150 watts	2	no	no
	2065	\$49.95	20	n.a.	4,000	200 watts	2	yes	yes
FASCO	2002	n.a.	20	n.a.	2,700	140 watts	2	n.a.	yes
	2005	n.a.	20	n.a.	3,000	150 watts	2	yes	yes
	2075	n.a.	20	n.a.	3,200	150 watts	3	yes	yes
FRESH'ND-AIRE	208-CR	\$49.95	20	n.a.	3,250	n.a.	2	yes	yes
	T-128	\$59.95	Twin 12	n.a.	2,500	n.a.	3	yes	n.a.
	ER-208	\$64.95	20	n.a.	3,250	n.a.	3	yes	yes
	FS-208	\$69.95	20	n.a.	3,250	n.a.	3	yes	yes
GENERAL ELECTRIC	W-6	\$29.95	20	2,100	4,000	170 watts	n.a.	no	no
	W-8	\$34.95	20	2,100	n.a.	160 watts	n.a.	no	no
	W-9	\$44.95	20	2,100	n.a.	150 watts	n.a.	no	yes
	W-7	\$44.95	20	2,100	4,000	170 watts	n.a.	no	yes
	T-4	\$59.95	Twin 12	1,500	2,500	140 watts	3	no	yes
	P-3	\$59.95	20	2,100	4,000	170 watts	3	no	no
	W-10	\$69.95	20	2,100	5,000	175 watts	3	yes	yes
HUNTER	J-20	\$29.95	20	2,100	n.a.	170 watts	2	no	no
	D-2058	\$39.95	20	1,900	3,000	150 watts	n.a.	no	yes
	D-202	\$44.95	20	2,100	3,400	130 watts	2	no	yes
	D-201	\$49.95	20	2,100	3,400	130 watts	2	yes	yes
	U-201	\$64.95	20	2,200	4,000	135 watts	2	yes	yes
	W-181	\$64.95	18	2,350	3,600	185 watts	2	yes	yes
	W-12	\$79.95	Twin 12	2,000	2,900	185 watts	2	no	yes
	W-221	\$84.95	22	3,400	4,800	220 watts	2	yes	yes

facts and figures

MAKE	MODEL	LIST PRICE	BLADE SIZE (in.)	AIR-MOVING CAPACITY (cu. ft./min.)		MANUFACTURER'S MOTOR RATING	NUMBER OF SPEEDS	BUILT-IN THERMOSTAT?	REVERSING SWITCH?
				Exhaust	Circulating				
ILG	204	\$72.95	18	n.a.	3,550	n.a.	n.a.	no	no
KNAPP-MONARCH	7-544	n.a.	20	n.a.	3,500	1/15 hp.	3	no	no
	7-548	n.a.	20	n.a.	3,500	1/15 hp.	3	no	yes
	7-554	n.a.	20	n.a.	3,500	1/15 hp.	n.a.	yes	yes
LAKEWOOD	MX 720-3	n.a.	20	2,800	n.a.	1/15 hp.	3	n.a.	no
	MX 720-2	n.a.	20	2,800	n.a.	1/15 hp.	2	n.a.	yes
LAU	20RW	\$29.95	20	n.a.	3,950	170 watts	2	n.a.	yes
	20PR	\$39.95	20	n.a.	3,950	170 watts	2	n.a.	yes
	Super 16	\$44.50	16	n.a.	3,000	110 watts	n.a.	n.a.	n.a.
	Super 20	\$49.95	20	n.a.	3,950	162 watts	3	yes	n.a.
	Ultra 20	\$69.95	20	n.a.	3,950	162 watts	3	yes	yes
MANNING-BOWMAN	200MI	\$47.95	20	n.a.	n.a.	2.5 amps	2	yes	no
	1252MA	\$49.95	Twin 12	n.a.	n.a.	150 watts	1	no	no
	9020	\$49.95	20	n.a.	n.a.	2.2 amps	2	no	no
	200MO	\$59.95	20	n.a.	n.a.	2.2 amps	2	no	yes
MONTGOMERY WARD	86A2468MO	\$32.95	20	n.a.	2,600	n.a.	3	no	no
	86A2451R	\$32.95	20	n.a.	3,100	n.a.	3	no	no
	86A2466MO	\$44.95	20	n.a.	3,600	n.a.	3	yes	yes
	86A2560R	\$44.95	20	n.a.	3,600	n.a.	3	yes	yes
	86A2455MO	\$48.88	20	n.a.	5,100	n.a.	3	yes	yes
	86A2458R	\$62.50	22	n.a.	4,600	1/6 hp.	2	no	yes
SEARS, ROEBUCK	42H09321L	\$19.95	20	1,850	n.a.	1/15 hp.	2	no	no
	34H08036L	\$21.95	20	n.a.	2,400	1/16 hp.	2	no	no
	42H09383L	\$29.50	20	1,850	n.a.	1/15 hp.	2	yes	no
	34H08067L	\$31.95	20	n.a.	3,200	1/12 hp.	3	yes	no
	42H09361L	\$39.95	20	2,450	n.a.	1/12 hp.	2	no*	yes
	34H08068L	\$41.95	20	n.a.	3,300	1/2 hp.	**	yes	yes
	42HM9390	\$57.50	20	3,850	n.a.	1/5 hp.	2	no*	yes
	34HM8108	\$62.50	20	3,850	n.a.	1/5 hp.	**	yes	yes
	42HM9348	\$67.50	24	4,250	n.a.	1/8 hp.	2	no*	yes
SILEX	3329	\$44.95	20	1,800	3,000	155 watts	2	no	yes
	3322	\$49.95	Twin 12	1,400	2,225	140 watts	n.a.	yes	n.a.
VIKING	720	n.a.	20	2,400	3,200	1/15 hp.	2	no	no
	1020	n.a.	20	2,500	3,600	1/15 hp.	2	yes	yes
	955	n.a.	22	3,500	n.a.	1/6 hp.	2	no*	yes
VORNADO	16AI	\$44.95	16	n.a.	3,325	128 watts	2	no	no
	20AI	\$49.95	20	n.a.	4,865	162 watts	2	no	no
	16AT	\$54.95	16	n.a.	3,325	128 watts	2	yes	no
	20AT	\$59.95	20	n.a.	4,865	162 watts	2	yes	no
	16AR	\$64.95	16	n.a.	4,025	63 watts	2	yes	yes
	20AR	\$69.95	20	n.a.	5,111	101 watts	2	yes	yes
	20AS	\$79.95	20	n.a.	5,111	101 watts	2	yes	yes
WESTINGHOUSE	R 2021	\$44.95	Twin 10	800	2,000	125 watts	2	no	no
	CS 3522	\$46.90	20	2,100	3,500	230 watts	2	no	no
	CD 3522	\$56.90	20	2,100	3,500	200 watts	2	no	yes
	R 4521	\$64.95	17	3,400	4,500	250 watts	2	no	no
	AC 4021	\$69.95	20	2,900	4,000	170 watts	2	yes	yes
	AC 4022	\$69.95	20	2,600	4,000	170 watts	2	yes	yes

NOTE: n.a. This information not available *Has timer **Continuously variable

Which Fan Would You Buy?

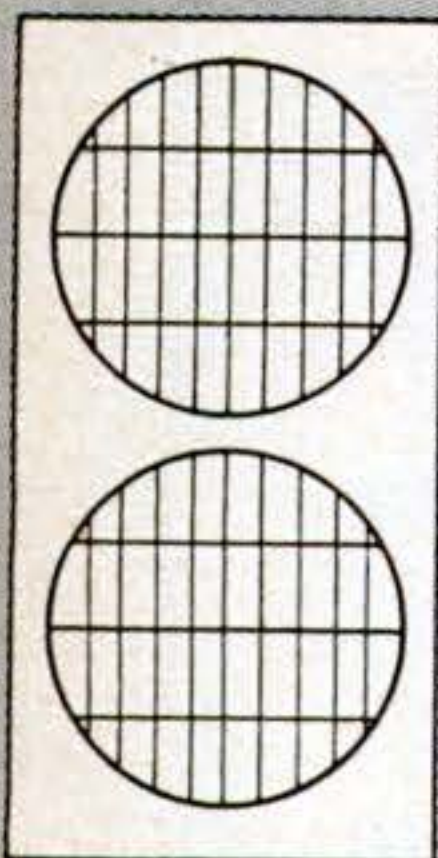

TWIN 10" FANS

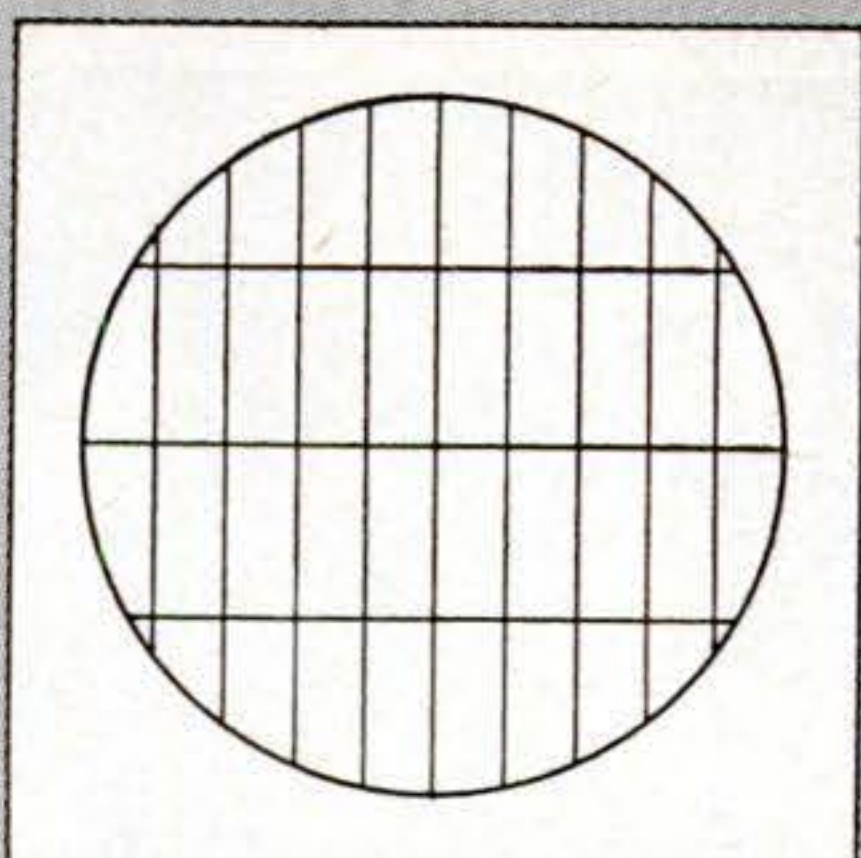

SINGLE 20" FAN

Why they aren't the same:

$$\text{AREA OF CIRCLE} = \pi R^2$$

AREA OF 2 10" FANS

$$\begin{aligned} &= 3.1416 \times 5^2 \times 2 \\ &= 3.1416 \times 25 \times 2 \\ &= 3.1416 \times 50 \\ &= \mathbf{157.08} \text{ SQ. IN.} \end{aligned}$$

AREA OF 1 20" FAN

$$\begin{aligned} &= 3.1416 \times 10^2 \\ &= 3.1416 \times 100 \\ &= \mathbf{314.16} \text{ SQ. IN.} \\ &(\text{TWICE THE AREA} \\ &\text{OF TWO 10" FANS}) \end{aligned}$$

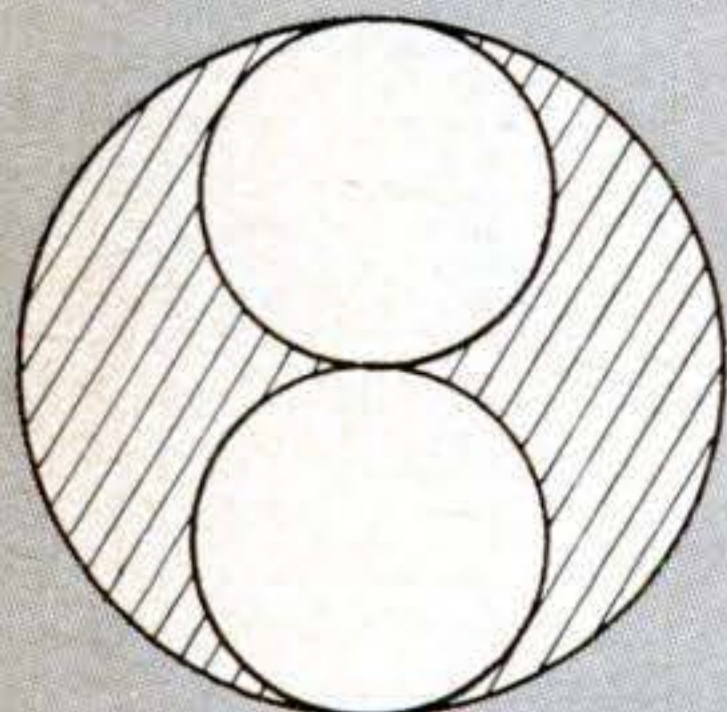

TWO 10" CIRCLES
FIT INSIDE ONE
20" CIRCLE WITH
ROOM TO SPARE

WHY TWO SMALL FANS DON'T EQUAL ONE BIG ONE is shown above. Total area of twin 10" fans is only half that of one 20" fan. Actual air-moving capacity is cut one-third to a half. Twins are good for narrow windows, but you should use single large fan wherever possible.

ly sufficient. In warmer southern areas, an air change every one or two minutes is required. A fan with a capacity of 2,000 cubic feet per minute (c.f.m.) will thus change the air once every minute in a 2,000-cubic-foot room or once every three minutes in a 6,000-cubic-foot room (or the equivalent in several small rooms put together).

If you figure the cubic feet in your own rooms (length times width times height), you can tell how much capacity you need. But now here's the joker. The published capacity of a fan may apply only to its

"circulating" rating—the amount of air it can move in the open. What you really want to know is the "exhaust" rating—the amount of air it can pull out the window. When matching a fan to a room, always use this exhaust rating (sometimes called "ventilating" rating).

A fan with a circulating rating of 4,000 c.f.m. may have an actual exhaust rating of only 2,500 c.f.m. Where you can get only the circulating rating, you can figure that the exhaust capacity will be only two-thirds to half as high.

To protect the consumer against misleading specifications, several trade associations have established standards for measuring fan performance. Most fans have the approval of such recognized associations as NEMA (National Electrical Manufacturers Assn.), AMCA (Air Moving and Conditioning Assn.), NAFM (National Assn. of Fan Manufacturers), PFMA (Propellor Fan Manufacturers Assn.), and ASHAE (American Society of Heating and Air-Conditioning Engineers).

What does blade size mean? Most manufacturers have settled this year on the 20" size, which is the diameter of the blades. A few makers still offer a 16" or 17" size for use in windows too small to take the 20" size.

Blade size alone, however, does not determine capacity. Two identical-looking 20" fans may differ as much as 1,000 c.f.m. in air delivery—enough to handle a fair-sized room. No matter what size you pick, the best buying yardstick is still: rated capacity in c.f.m. Do not, however, ever buy a larger blade size than the window opening, even if you can fit the fan in front of the window. A partially blocked fan will set up back pressure against the blades and put a strain on the motor.

How about twins? Double fans—usually two 10" or 12" units mounted in a single frame—are fine for very narrow windows, such as casements, where larger fans won't fit. Their combined capacity, however, is much less than that of one 20" fan. (If you compare the area of two 10" circles with one 20" circle, you can quickly see why this is so.)

[Continued on page 204]

NEXT MONTH

: *What wrenches do you need in your house? What size? How should you use them? August PS features a tear-out booklet on these valuable tools: "Choosing the Right Wrenches."*

what's new

.....



the latest in tools

New circle-cutting jig above is an adjustable version of the old pivot-sawing trick. You set a pin to any desired radius, as at right, make a series of straight cuts, then rotate the wood against the saw. American Home Tool Corp. sells the jig for \$4.95.

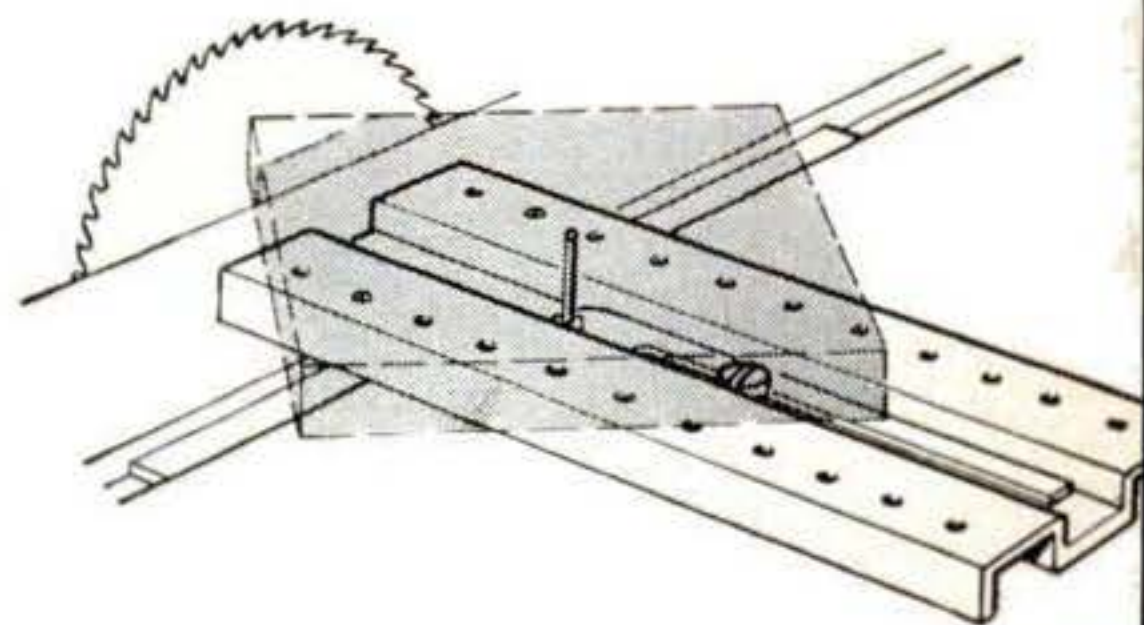

Interchangeable chucks on a new line of Stanley tools let you have either a $\frac{3}{8}$ " electric drill (upper right) or a power driver (lower right) for running in screws or nuts. The power-driver chuck has an impact-type friction clutch that automatically lets go under a sudden overload. It takes a full line of slotted and Phillips screwdrivers, socket-wrench heads and shaft extensions. The tools will be sold separately as two drill models (\$39.95 and \$44.95) and as two power-driver models (\$42.95 and \$48). Additional chucks will then be made available for conversion of either type to the other. All models are rated at 2.5 amps, 800 r.p.m.

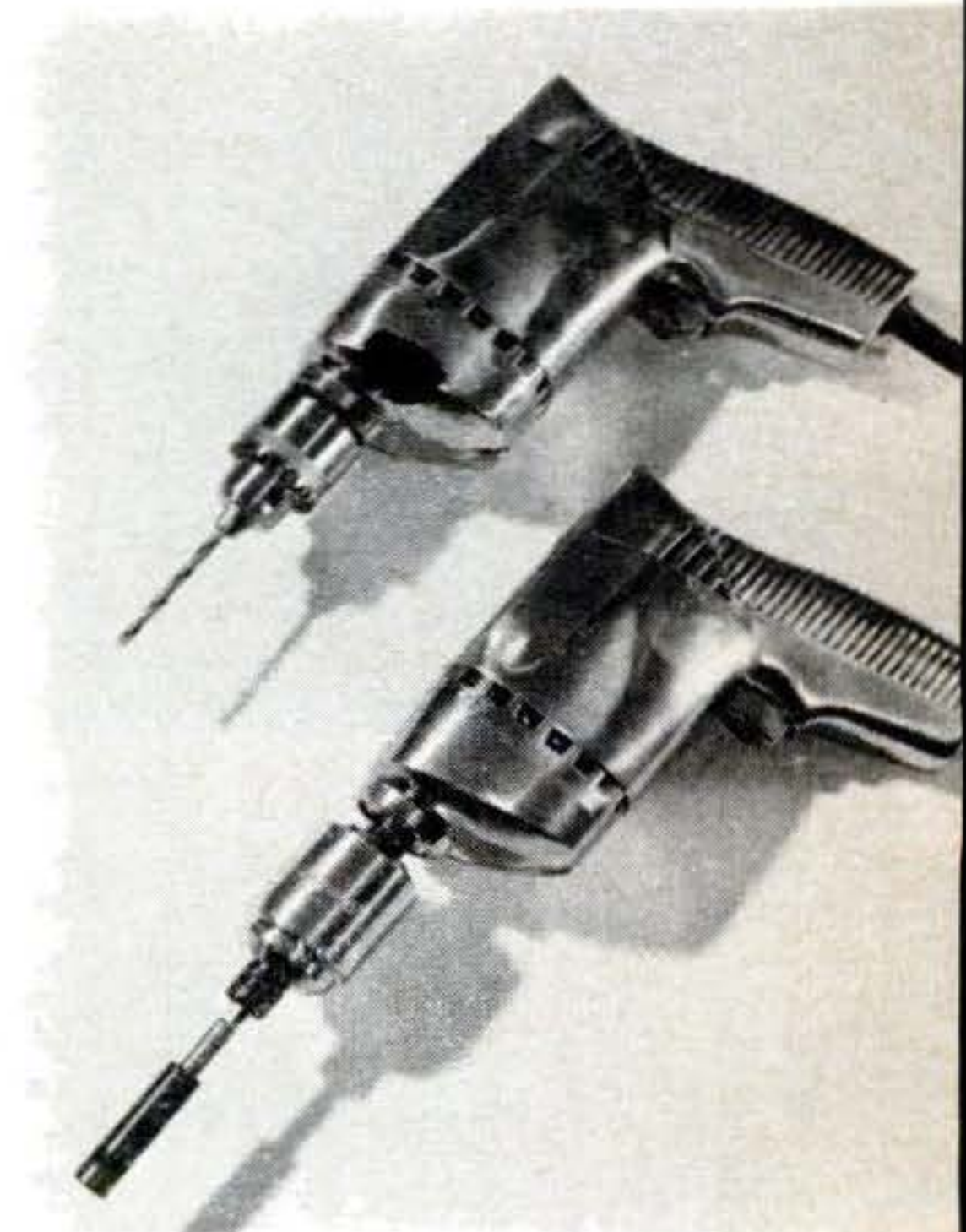

Soft-faced hammers with replaceable heads can get banged up without becoming ruined. The heads are made of Tenite plastic, and when one set wears out you simply screw on another set. Made by Custanite Corp., the mallets come in two-, $2\frac{1}{4}$ - and three-pound sizes, and are said to reduce shock and bounce in use.

Please turn the page for more new products

JULY 1958 139

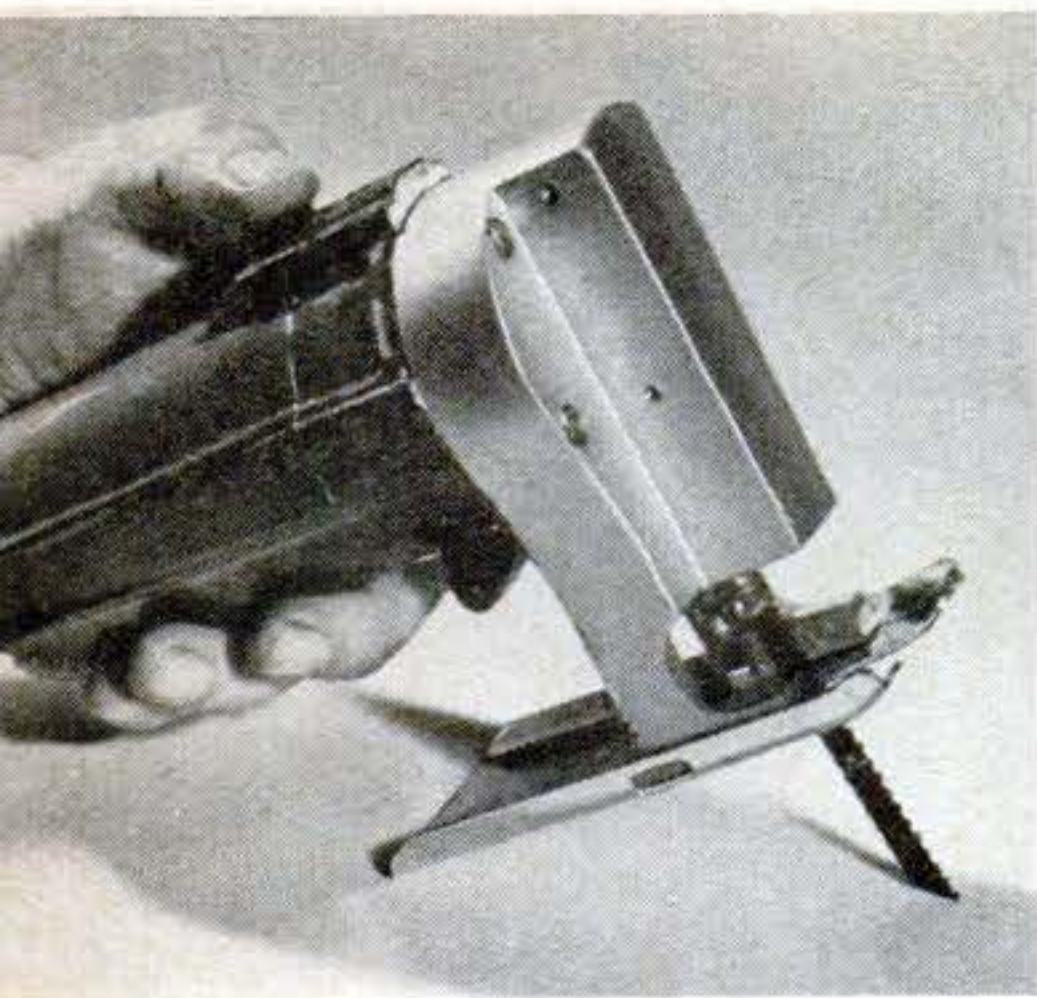

Latest electric handsaw to join this fast-growing field is the new-model Wen at left, now available as a kit that includes carrying case, five blades and a rip and circle-cutting attachment for \$32.95. The saw has a built-in chip blower, is said to cut 1/2" steel, 2" wood.

A sliding-jaw C clamp can be quickly set to fit the work, saving clamping time. Made by Research Engineering, it has a flat, sturdy base so it can also be used as a stand-up jig . . . For those who don't like the fine print on micrometers, Brown & Sharpe has a **direct-reading micrometer** that pops up big-size numbers behind a plastic window—like your car's mileage counter.

what's new for the family car

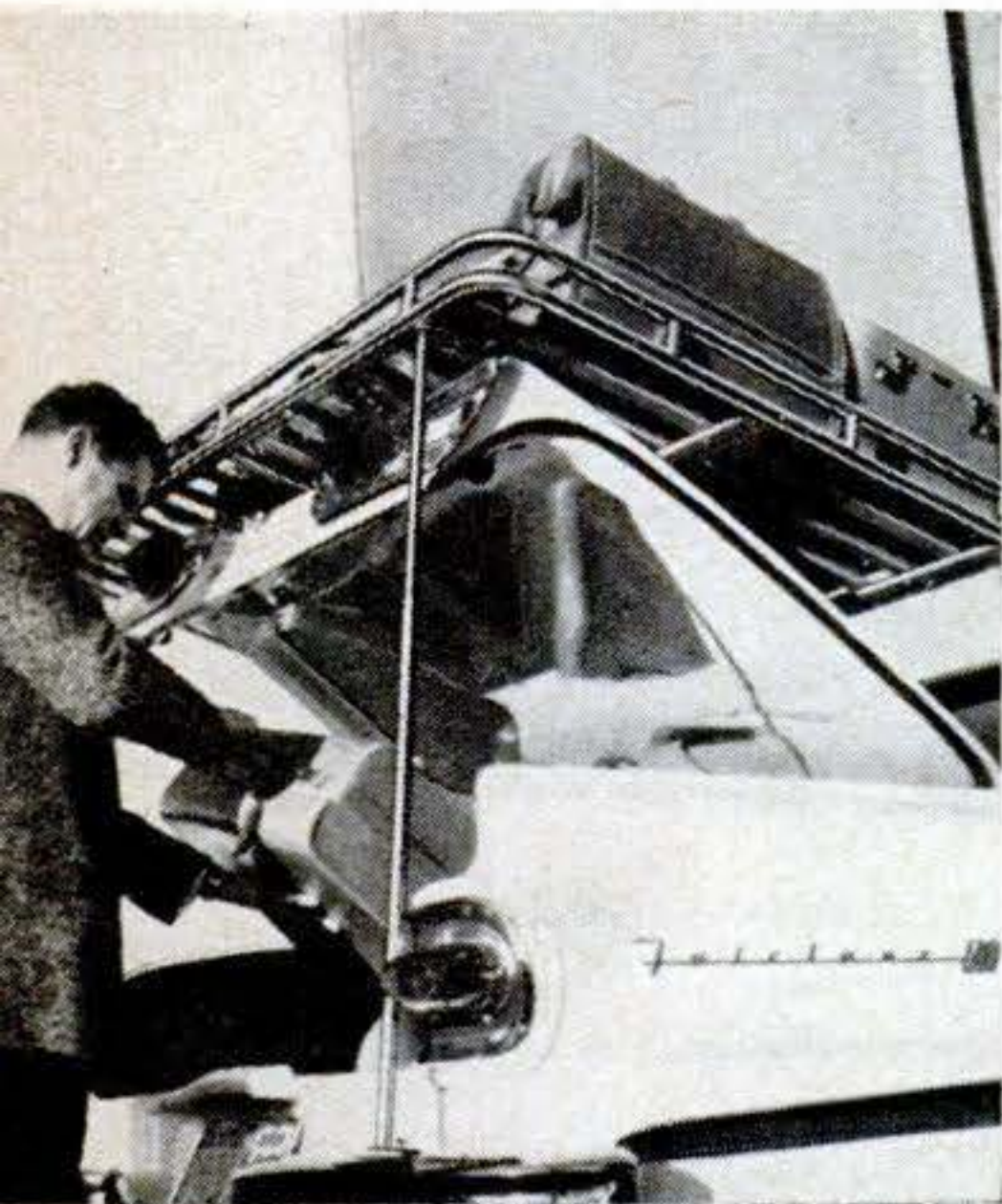

An extra "trunk" on top of the trunk (at left) makes it easy to add luggage space to convertibles and other cars that can't take a roof rack. The detachable rack is hinged at the front just above the rear deck and can be quickly raised on two telescoping poles at the rear when you want to open the trunk lid. The Benmatt Organization sells the 36"-by-62" chrome-and-hardwood deck for \$79.50.

Your car can't slip off the jack, with a pair of adjustable chocks sold by Burbank's. Two wedge-shaped blocks are fitted around a wheel and tightened together so the car can't roll forward or backward. Price is about \$7.

Dash-mounted coin dispenser keeps four nickels and six dimes or pennies within easy reach for tolls, parking meters or telephone calls. Car-Coin Co. sells the plastic holder for \$1.



Convertible camping trailer, at left, when unfolded turns into a 13' plastic boat or—guess what—a 16"-deep wading pool for the kids. On the road, the Aqua Trailer will haul up to 700 pounds. Price is \$795 . . . **An electric-powered backrest** gives you a motorized back rub as you drive, said to reduce fatigue and relax stiff muscles. Made by Niagara, the massaging pad just plugs into the cigarette-lighter socket . . . **Less static interference in car radios** is the claim of a new antistatic powder that can be blown into your tires. A kit, including valve injector, is sold by Speedex for \$2.75 . . . **A remote-controlled side mirror** can be tilted up or down or rotated by turning a knob on the dash. Alted Corp. sells it for about \$11.

for more information:

Here's where to write if you can't get any item listed above: Alted Corp., P. O. Box 118, Bangor, Mich.; American Home Tool Corp., 350 Broadway, NYC; A M I Inc., Grand Rapids,

Mich.; Aqua Trailers, Inc., North 1039 Division, Spokane, Wash.; Benmatt Organization, 962 Milwaukee Ave., Chicago 22; Brown & Sharpe Mfg. Co., Providence, R.I.; Brunt-Maker, 516 University Bldg., Denver 2, Col.; Burbank's, 10 Burbank St., Oxford, Mass.; Car-Coin Co., P. O. Box 6838,

for the home handyman

New heat-reflecting roof panels, at right, have a thin sheet of perforated aluminum foil sandwiched between layers of corrugated plastic. The aluminum lets in light through the holes, but is said to block 80 percent of the sun's heat, keeping a porch or patio cool underneath. The Resolite panels come in four colors, 26" or 40" wide and 8', 10' or 12' long. You can drill, saw and nail them in the same way as conventional plastic panels. Price is \$1.25 a square foot.

Three lawn-watering aids: *A combination sprinkler-soaker hose* can be adjusted to give anything from a full spray to a fine trickle—by sliding sleeve valves over slits in the side of the hose. It's sold by Grotel in 30' lengths for \$5.95 . . . *A slide-type valve*, made by Melnor, quickly turns water on or off at any point along a hose line without your running back to the faucet . . . *A spring-clip hose holder* clamps to a stake, fence, pail or other support to free your hands. Rite-Flo sells it for 80 cents.

New awnings roll up and down like a window shade to give you any amount of sun or shade you want. The awning material winds itself up on a hinged aluminum frame that can be set at any angle outside the window. Five widths are available from 36" to 60" for about \$20 to \$30 apiece. Pyramid, the maker, says the awnings can't leak, rot or mildew and need never be taken down.

For the handywoman: *A portable tubless clothes agitator* that converts any tub or large pail into a washing machine. The electrically powered unit is 6 $\frac{3}{4}$ " in diameter, weighs only about 9 $\frac{3}{4}$ pounds, and will handle up to four pounds of wash at a time. Made by A M I, it will sell for \$59.95.

Universal curtain-rod brackets are put up once and left in place no matter how many times you change rods. Clamps on the brackets let you attach all styles of curtain hardware without drilling fresh holes every time a new type is put up. The brackets are sold by Brunt-Maker for \$1.65 a pair.

Sheldon Gallager



Kansas City, Mo.; Cusanite Corp., 1228 Utica Ave., Brooklyn 3, N.Y.; Grotel, P. O. Box 611, La Habra, Cal.; Melnor Industries, 300 DeWitt Ave., Brooklyn 36, N.Y.; Niagara Cyclo-Massage Co., 138 E. 60th St., NYC; Pyramid Co., 1384 Broadway, NYC; Research Engineering and Sales Co.,

1014 Longfellow, Royal Oak, Mich.; Resolite Corp., Zelienople, Pa.; Rite-Flo Mfg. Co., 1922 S.W. 1st St., Des Moines, Iowa; Speedex Mfg. Co., 400 S. Wyman St., Rockford, Ill.; Stanley Tools, 111 Elm St., New Britain, Conn.; Wen Products, 5810 Northwest Highway, Chicago 31.

New Carry-Along Spray Compressor

*builds up air pressure
like a supercharger*

A ROTOR compressor no larger than a quart can of paint now puts the air supply for big spraying jobs in the palm of your hand. You can hold it easily while you climb a ladder, or work from one end of a long fence to the other. It weighs a mere 4½ pounds.

The tiny compressor is the heart of a new paint-spraying rig called the "Sprayit 400." It works on the principle of a miniature supercharger. Under its cast-aluminum housing a quarter-horse motor revs a small rotor up to 8,000 r.p.m. The result is an output of about 1½ cubic feet of air per minute, delivered at a constant working pressure of about 18 pounds to the square inch.

While this pressure is lower than that delivered by some other compressors, the Sprayit 400's pressure-feed-type gun has the effect of upping the 18 pounds. "Pressure feed" means that air is driven into the canister to lift paint to the nozzle, rather than drawing it up, siphon-fashion, by an overblast. This offers much greater lifting power in relation to air pressure—important when you're handling heavy-bodied materials.

An internal-spray nozzle—one in which air and paint come together within the cap—again makes the most efficient use of compressor output. Once you plug in the motor, air bleeds through this nozzle constantly, preventing back pressure. Triggering the gun starts and controls the flow of paint.

Two adjustments give you just about any size and shape of spray pattern you want. You can produce a vertical or horizontal oval depending on which way you turn the slotted nozzle tip. For fine pinpointing, the pattern can be narrowed down to the size of a dime. For large coverage, it can be blown up to about a foot in diameter.

Under tests, the gun has successfully sprayed all sorts of materials from thin insecticides to thick house- and floor-paints. Even quick-drying lacquers have not clogged the nozzle during shut-off periods of up to 10 minutes between spray coats. Best bonus of the low-pressure air delivery is said to be the very small amount of overspray—the slop-over of spray where you don't want it. This is as little as an inch with the gun held about a foot away.

Made of high-impact-resisting plastic, the gun is light and has a comfortable two-finger trigger grip. A small stand on the bottom of the compressor doubles as a good hand grip, and a thermal cut-out on the motor guards against excessive heat.

The compressor runs at a high-pitched whine—louder than the noise of a vacuum cleaner. The Sprayit 400 sells for \$39.95, and is a product of Thomas Industries, Inc., 410 South Third Street, Louisville 2, Ky.—*Henry B. Comstock.*

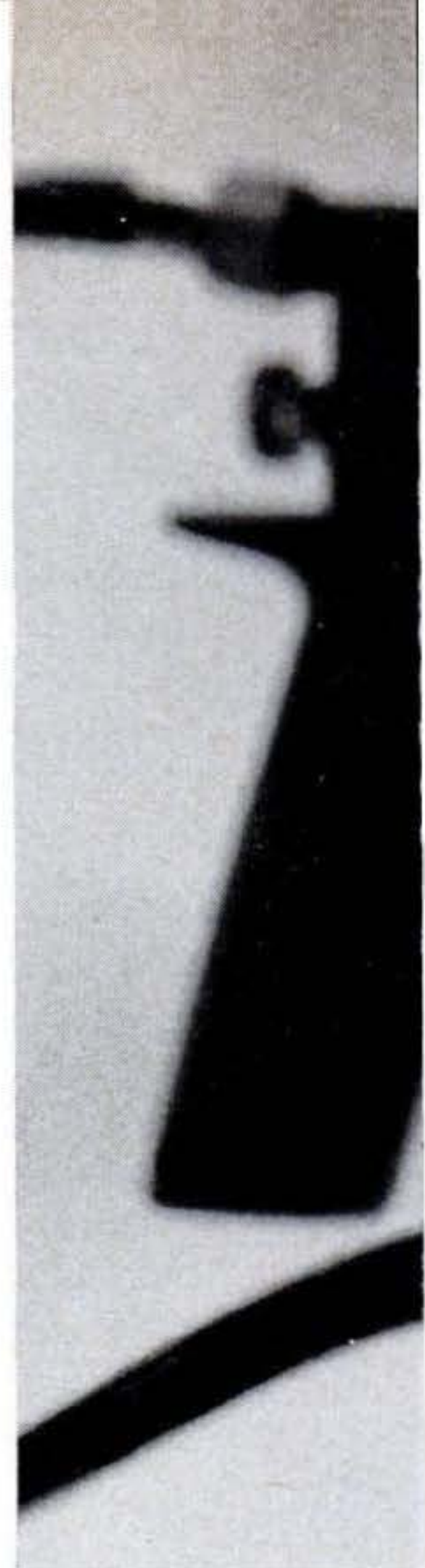

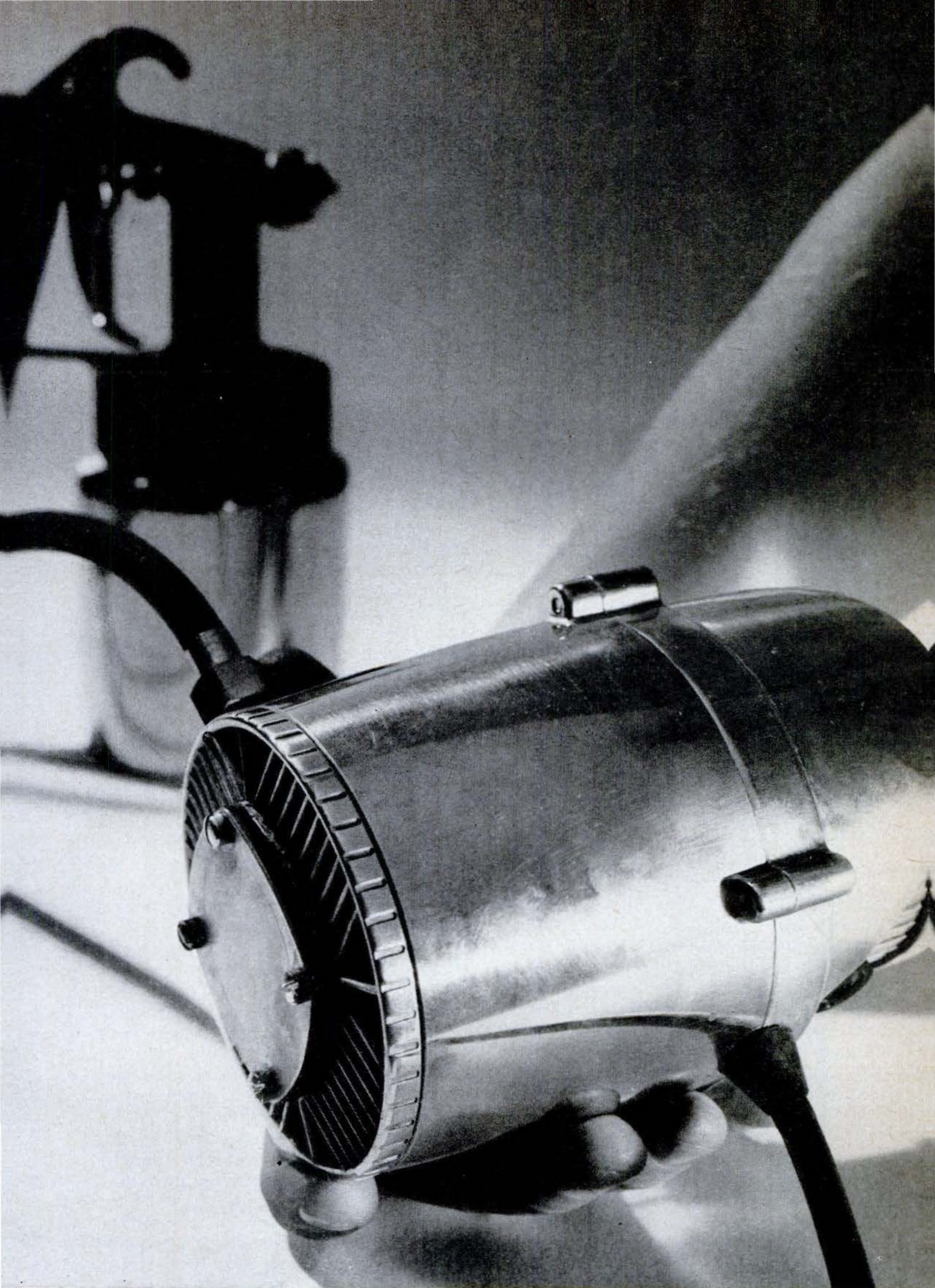

The Big Bargains in Two-Eyed Cameras

By Maryann Smith

SO YOU want to buy a camera that will take snapshots—that's all. But the store clerk drags out an expensive-looking, knob-littered box that has not one but two lenses—one to take the picture and one to let you see what the camera is taking.

This, he starts to explain, is a twin-lens reflex. It has all the pro features . . .

You're not a pro, don't want to be a pro and certainly don't want to pay pro prices. You explain that what you really want is a simple camera—one that will give you good enough drugstore prints to please the wife and kids without costing an arm and a leg or requiring a graduate degree in physics to operate it.

The clerk brings out another camera. It has two eyes, just like the first one. He's not fooling *you*—this is a reflex, too. Probably expensive.

\$17.95, he tells you. On the shelves, you begin to notice row upon row of the same two-eyed, boxy-looking cameras. The price tags run \$23.46, \$29.50, \$37.75, \$46.95, \$58.50—all the way up to \$200 and \$300 models. You're bewildered. Who buys these things? Why the big differences in price?

Big boom in reflexes. The fact is, more than half a hundred different makes of twin-lens cameras have crowded onto dealers' shelves, most of them within the last two or three years. More than half of all models on the market sell for less than \$60—and half of *these* sell for even less than \$30.

Obviously, the lowest-priced models aren't bought by professionals. They *are* bought, say dealers, by everyone from experienced amateurs to casual vacationing snaphooters. The twin-lens design has become so popular, in fact, that it is already setting something of a pattern for many simpler cameras.

The one the clerk showed you for

\$17.95, for instance, is Kodak's Duoflex. While essentially a fixed-focus box camera, it has many advantages of higher-priced models. You look down through a large viewfinder in the top, as with any reflex, and see the scene you want to shoot exactly as it will appear on the film.

Both Ansco and Argus also make similar box cameras using the two-lens principle. All have self-cocking shutters, built-in double-exposure prevention, and can be equipped with flash. There's even a twin-lens Brownie, at \$10.75, which has been one of Kodak's biggest sellers.

Why a reflex? Its ability to take a picture through one lens and let you see what you're taking through another lens is the chief charm of the twin-lens—and the chief reason for its popularity. If you recall the many home snapshots with lopped-off heads and tilted horizons, you can see why. The twin-lens reflex takes the guesswork out of planning and posing a picture.

In cameras with adjustable focus, this is an even greater advantage. The lower, picture-taking, lens is arranged to work together with the upper viewing lens. As the scene becomes crisp and clear in the viewfinder, you know that the taking lens is also in focus.

The twin-lens reflex is a happy compromise: It provides for those who want to shoot for black-and-white prints and those who want color slides. Most models use either 120 or 620 film, which both provide a 2 $\frac{1}{4}$ "-square picture. This is small enough for projection of color, yet large enough to give you direct prints without requiring enlargements.

Just in the last year, two smaller versions using 127 film have been brought out: at \$133 by the German firm that makes the classic Rollei, and at \$59.95 by the Japanese makers of the fast-selling Yashica. The two provide a 1 $\frac{5}{8}$ "-square picture that cuts considerably the cost of color film. Kodak's little Brownie



UNDER \$15

Penta Reflex



UNDER \$20

Kodak Duoflex



UNDER \$30

Tower (Sears, Roebuck)

The classic reflexes still come high—but many low-cost makes use the same design

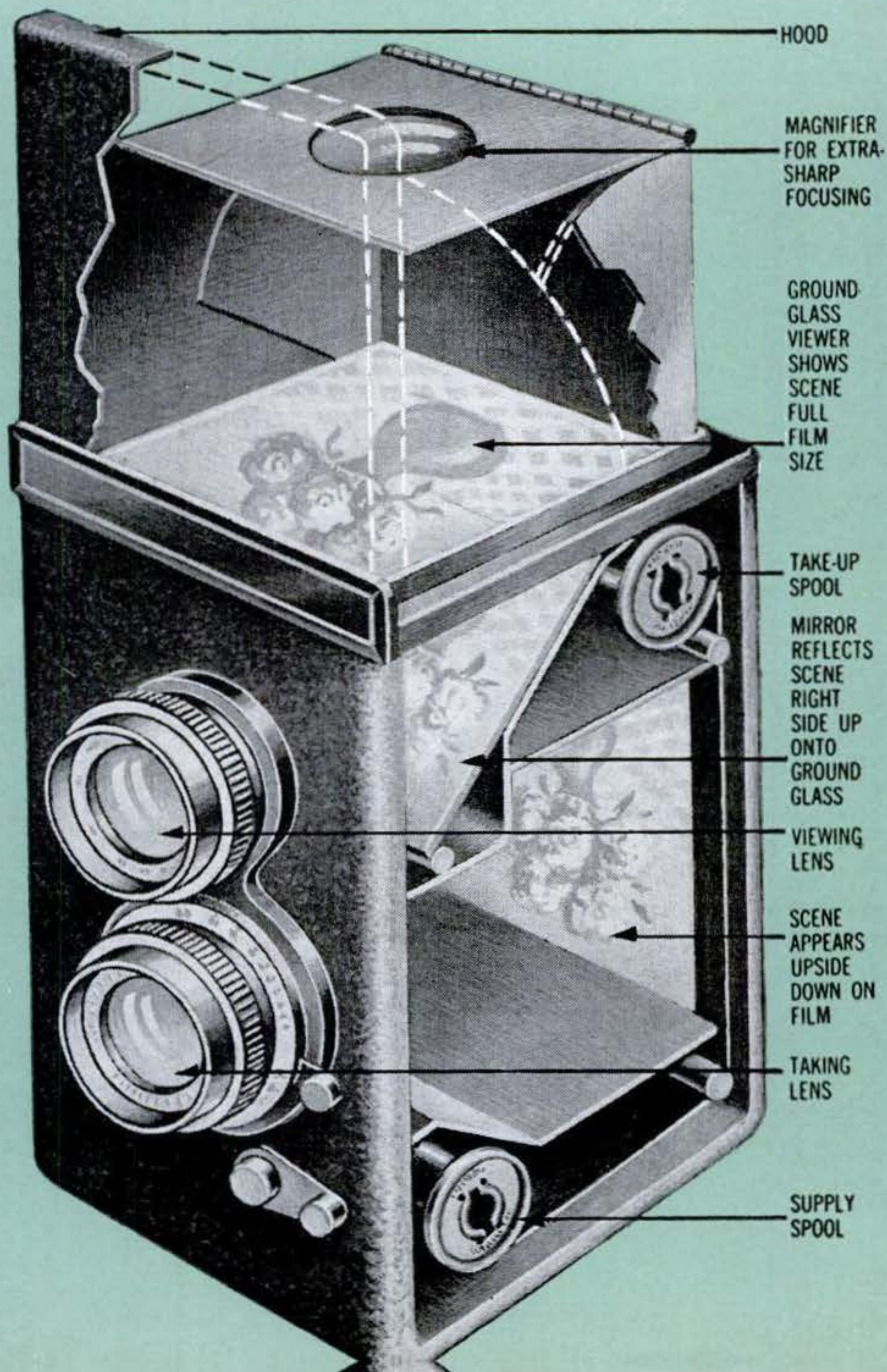

UNDER \$40

Royalcord

Yashica "44"

UNDER \$60



also uses 127 film, and other models are likely to appear soon. Several models (including Rollei, Ricohflex and Yashica) also let you use the still-cheaper 35-mm. color film in the same 2 $\frac{1}{4}$ " cameras by means of adapters. These are important if you plan to go in for 35-mm. color slides.

What do you really get? Perhaps you wonder if bargain prices aren't just for the very cheapest cameras. The store clerk lines up five or six more cameras on the counter. \$29.95, he tells you—all of them. What's more, he points out, you get an f/3.5 lens. Only a few of the most expensive models have faster f/2.8 lenses. You



CRANK-TYPE REFLEX moves film and cocks shutter automatically. Kalloflex above (sold by Graflex) combines crank and focusing knob in novel one-hand arrangement, sells for \$119.50.

also get shutter speeds up to 1/300 of a second—fast enough to shoot pretty nearly anything you'll want to point a camera at. Sears, Roebuck (Tower) and Montgomery Ward (Wardflex) sell similar cameras, both also priced at \$29.95.

How good are they? At these prices, you naturally don't get all that a \$300-plus model will give you. But you do get a whale of a lot. Mass production and the rising popularity of twin-lens cameras have brought the price down. And today's films make it possible for inexpensive cameras to take much better pictures than they used to.

Extra features. What else you get beyond a basic camera depends on how much you spend for added convenience.

The Penta Reflex, at \$14.95, is currently the lowest-priced true twin-lens reflex with

an f/3.5 lens and speeds up to 1/100 of a second. The Super Ricohflex, at \$19.95, is the lowest-priced model with interchangeable backs to permit the use of both 120 and 35-mm. film. Up to about \$46, you'll get shutter speeds up to 1/300 of a second; beyond this, you can expect speeds of 1/400 and 1/500.

Most inexpensive models, up to about \$40, use a lever on the front to focus the lens. On higher-priced cameras, look for a focusing knob on the side, which you may find easier to handle than reaching around in front of the camera. In the \$40-and-up bracket, you'll also find an automatic film stop. You just start the film at the first frame and from then on it automatically stops at each frame as you wind the advance knob. The Royalcord, at \$39.95, is the lowest-priced camera to have this feature.

One point to check carefully is the overall brightness of the ground-glass viewfinder. The brighter it is, the easier it is to see and focus. You may find that some of the less expensive cameras rate as well or better on this than the top models.

Built-in light meters begin coming into the picture at \$59.95. And once you hit the \$75-and-up bracket, you're in the film-crank class. (The 127-film Yashica "44," at \$59.95, is the one lower-priced exception.) One turn of the crank advances the film and also sets the shutter. At \$119.50, the Kalloflex (sold by Graflex) has a combination film crank and focusing knob so you can work both controls with the same hand.

As you keep going over the \$100 mark, more of the aperture and shutter-speed mechanisms are coupled. You make the initial setting, and thereafter if you want to change either the f-stop or speed, the two move with one motion.

In many instances this coupled system, referred to as Exposure Value System (EVS) or Light Value Scale (LVS), works in conjunction with a built-in light meter.

Interchangeable lenses are the newest development offered by two twin-lens cameras in the top-price field. The Mamiya comes with a standard 8-mm., f/2.8 lens for \$159 and offers (at extra cost) four additional wide-angle and telephoto lenses. The Koniflex comes with both standard and telephoto lenses included for \$300. END

What to do **If You Have**
an Auto Accident

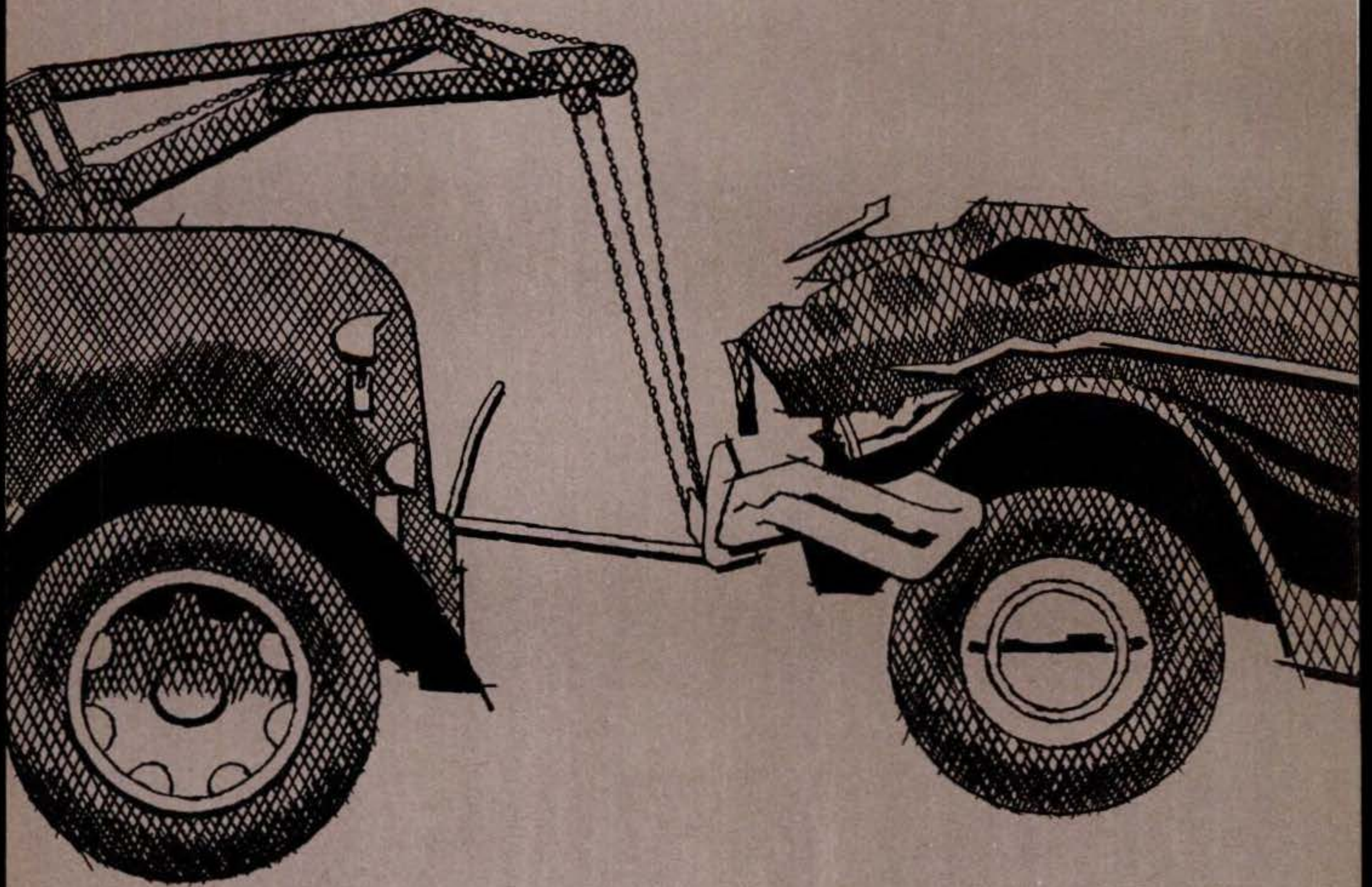

Where to find the facts

Foreword	2
First Things First	3
If Anyone's Hurt	3
Types of Insurance	4
Reporting the Accident	4
Who's at Fault?	5
If Insurance Claims Bog Down	6
Getting Repairs	7
Do You Need a Lawyer?	8
Settling for Injuries	9
Checklist	10

Foreword

ACCORDING to the grim averages of the road, you stand a one-in-three chance of meeting with an auto accident some time this year. Fortunately the same statistics say it's likely to be a minor scrape, but the smallest injury you can figure to get away with is a case of writer's cramp.

Filling in forms and asking and answering questions is a serious business.

Though you may think you're fully insured, damage claims—including unjustified ones—could strip you of everything you own or tie up your income for life. And even if you're an innocent victim you can put yourself in the wrong by what you do or fail to do.

So it makes sense to learn the ropes before you find yourself dangling from them. Then, if the need ever arises, you'll be able to practice the basic rules of post-accident protection: Keep cool, and know what you're doing.

First things first

Regardless of who's at fault—and there are good reasons for *not* trying to parcel out blame on the spot—these are the first important steps:

- Turn off your ignition switch.
- Take care of any injured.
- Make sure your accident won't cause another. If the cars are in the way of oncoming traffic, move them or do what you can to warn off other drivers.
- Call the police (unless it's just a trivial scrape). Note the badge numbers and precinct or barracks locations of the officers who respond. You may later need their testimony or want to refer to their official reports. Answer police questions honestly, but don't elaborate.
- Exchange name, address, phone number and license information with the other driver. Do not lose your temper or get into arguments. And above all, *do not admit responsibility* even if you think you goofed. You aren't required to, and a generous admission may harm everyone concerned (see page 5).
- Collect other names and facts. Use

the checklist on page 10 to record data about the other car's driver, owner and occupants, as well as about injured persons and witnesses. (Witnesses often won't want to get involved and you can't force them to give their names. But if you can identify them by license number, house address, police report, or other means, you may later be able to subpoena their testimony.) Make a note of road and weather conditions and the time and location of the accident. Examine the damage suffered by the other car and look for previously acquired nicks and dents; if you should have to foot repair bills, there's no reason to take on any unrelated extras. If you have a camera along, take pictures of accident scene and damage.

You need a complete record of the events and people involved, because even when the facts of an accident seem crystal-clear, you can easily get bogged down in tricky repair procedures, claims, counterclaims and legal runarounds. And the exact sequence of your next moves may depend on who's insured for what.

If anyone's hurt

CALL a doctor or ambulance immediately if anyone is obviously hurt. Unconscious persons, or those who may have suffered fractures or head or spine injuries, should be kept warm until medical help arrives; *do not attempt to move them* unless it is urgently necessary to stop profuse bleeding or to protect them from fire or other harm.

In any severe shake-up it is a good idea to insist on medical attention for everyone; shock some-

times makes people unaware of physical injury. Offer to pay for examinations, if necessary, and if anyone still declines, ask the doctor or a policeman to take note of his refusal. This could help to prevent or reduce exaggerated claims of injury.

When a doctor is called, get his name and address and that of any hospital to which the injured are taken. Medical expenses may be recoverable, so get receipts for all bills you may be required to pay. If more than one patient is involved, keep the records separate.

Types of insurance:

Liability: Whether or not you are to blame, you can be *sued* for deaths, personal injury, or property damage inflicted by your automobile. Liability insurance will protect you against the costs of legal defense and—up to the limits of a policy—pay claims for which you are held legally liable.

Two types of liability insurance—one covering bodily injury, the other property damage—are available though they are usually packaged in one contract. If you're not sure your policy covers both, you'd better check it now.

Liability insurance pays for claims made against you, but not for any part of your own loss. The insurance usually covers your wife and other people who are authorized to drive your car.

Medical Payments: Medical and hospital bills for your own injuries—and

those suffered by your passengers—are probably not covered by your liability insurance. You may have to pay, unless you can sue the other party or you carry separate insurance for such payments. Medical-payments policies cover some shadowy areas in the law; for example, they'll pay medical costs for your passengers, who might be unwilling to sue you or might not be covered by your liability insurance.

Collision: If you have this kind of insurance, you can recover all or part of the cost of repairing your own car regardless of who caused the accident and—usually—without waiting through a long-drawn legal hassle. Nearly all collision policies have “deductible” clauses: You pay the first \$25, \$50 or \$100 and the company makes up the balance of what *it re-*

Reporting the accident

YOU must file an official report—and usually two or more. All states as well as some counties and municipalities require detailed information about accidents that cause injury or damage exceeding some fixed amount. You must submit the data on special forms, but regulations—governing the minimum damage that must be reported, the agency that handles the forms, and the amount of time you're allowed for filing—vary from state to state. Find out now what the law is in your locality and either obtain the blanks or make a note on the

checklist on page 10. Should an accident occur while you're away from home, ask the police how and where to file. Do it promptly. All states impose penalties for not reporting. In some they begin after 24 hours.

If you carry insurance, you must also notify the company in writing in order to keep your protection in force. Best procedure is to get in touch with your insurance agent or representative as soon as you can get to a phone. Ask him for help in filling out official reports. He probably can advise you about what you must—or need not—disclose.

what they cover

gards as a reasonable cost of repair or replacement. The policy doesn't allow for extras. You're not supposed to have old dents straightened out on the house. Damaged luggage, clothing and other contents are not covered. If the car is a total loss or repair costs would run too high, you can collect only the current value of the car. Towing costs may be included in the bill, but usually you cannot charge your collision company for substitute transportation (such as taxis or car rentals).

Having an insurance policy doesn't necessarily mean you're properly insured. If you made significant misstatements on your application, if you let the payments lapse, or if you failed to notify the company about changed conditions (such as new teen-age drivers in your family) you may discover that the pretty piece of paper doesn't mean the pretty things you think it says.

On the other hand a policy may have values that do not appear in the printed form. If you have an accident,

you will probably have to prove your "financial responsibility." Failure to do so may cost you your license, car registration, or the car itself until all claims are satisfied. You could establish your "responsibility" by posting a bond or putting up cash, but if you carry liability insurance your company representative will usually supply the needed proof.

Incidentally, don't confuse financial-responsibility with compulsory-insurance laws. New York and Massachusetts now require all car owners to carry liability insurance*; under the financial-responsibility laws in force in other states you don't have to insure but are subject to penalties *after* an accident if you can't pay damages.

**Massachusetts car owners must insure against death or bodily-injury claims but not property damage. A compulsory-insurance law will take effect in North Carolina July 1, 1959. In Connecticut, Maryland and Rhode Island, teen-age drivers must carry insurance.*

Who's at fault?

Responsibility for an accident, as it is finally parceled out, will have a lot to do with payments and losses. Keep in mind, however, that you—the car owner—are on the hook. Your insurance company stands behind you only if you have the right kind of coverage and don't fall through any legal loopholes.

Good sportsmanship could trip you up here because there's just no place for it in court. But the law does make

a distinction between *voluntary* and *legal* liability. Many insurance policies cover only the second kind—that is, the companies undertake to defend you as long as you cooperate and leave them a legal defense. If you erase this by voluntarily assuming blame for an accident (or by failing to notify the company), you may find that you have washed out your insurance protection.

So even if the accident occurred be-

cause you happened to be woolgathering and went steaming through a traffic light, your interests—and your victim's—will be best served if you keep your lip buttoned. This doesn't mean you should deny the facts or lie about them, but rather that you need not and should not talk about them except with a police officer who is legally authorized to question you. Do not sign any statements before you have discussed the case with a representative of your insurance company or your own attorney.

At least one reason insurance companies put such restraints on policy holders is that legal definitions of guilt are usually more complicated than may appear on the surface. In the most common type of accident—a collision at an intersection—both drivers share the blame more often than not, although not necessarily in the same degree. One insurance executive who has handled many thousands of cases says he's never heard of an intersection collision that could not have been avoided

by the exercise of reasonable care by either driver. You may feel completely sure of yourself because you know you had the right of way. But a jury could still find you guilty of contributory negligence. The test question is not whether you were in the right, but whether you had a chance to avoid the accident.

It's therefore unwise, as well as unnecessary, to try to establish blame at the time of the accident. This cuts both ways. If the other driver assumes responsibility, his insurance company may back out on him. You may then find it easier to get a judgment against him—but much tougher to collect damages after you get it. Then, too, you may fail to follow through on the procedures that would give you better protection if he should later change his mind and counter your charges with a set of his own. On the other hand, the most innocent acknowledgment you might make at the time could bounce back after you've forgotten it to confuse or discredit your later claim.

If insurance claims bog down

HARRIED by countless exaggerated claims and an almost universal belief that it's good form to stick them for all you can get, insurance companies have become suspicious of the public. The feeling is mutual.

If you plan to ask for car-repair costs under your own collision or the other fellow's liability policy, it's a good idea to notify the company involved and submit an estimate before you proceed with the work. Policies usually allow the

company a "reasonable" time to inspect the damage and the estimate before approving payment. A week is generally regarded as fair.

Most companies act promptly and in good faith, often getting a representative to the scene in a matter of hours. Some, however, have a reputation for dragging out settlements, especially of liability-damage claims.

Insurance men deny that any deliberate stalling goes on; impartial experts think there is less than is generally believed. But keep in

Getting repairs

Even if you were responsible, or think you were, for the accident, it can't hurt to keep the possibility of insurance recovery in mind when arranging for repairs. Blame needn't enter the picture if you carry collision insurance; and if the other driver was wholly or partly at fault, you may be able to collect additional expenses from him or his insurer. If you plan to make a claim, notify your own insurance company, the other, or both immediately (see opposite page).

Get duplicate, receipted bills for all payments you make as a result of the accident. Your collision policy will cover only approved repair and towing charges, less any deductible amount. But if you have a claim against the other driver, you may legitimately add necessary hotel bills, lost wages, car rentals, or other substitute-transportation costs, as well as damage to the

mind that the companies **hold most** of the trumps: You're **always free to** sue them, but it could **take years to** get a case to court. **Since** legal expenses would eat up a small claim (or the difference between what you ask and what they offer) you might have to drop the whole thing.

So it usually pays to follow the rules and avoid unreasonable actions or demands. If you then **feel** you're being treated unfairly, **consult** the complaint **office** of your state insurance department.

contents of your auto. You can, incidentally, take an income-tax deduction for any part of your actual accident loss that is not paid for by insurance.

If your car must be towed, find out the rates before you call a wrecker or allow him to hitch on. Some operators may try to pressure you into authorizing estimates or even repairs, so take time to read any "receipt" forms you may be asked to sign. Don't okay anything except towing until you've had a chance to find out more about the shop and facilities that are offered.

If you're far from home or just can't wait for an insurance adjuster before having your car fixed, try to get by with minimum repairs. Leave body work—usually the most expensive part of the job—until the damage has been inspected and an estimate agreed on.

In some respects you are between the jaws of a pincers. The lower you can keep repair bills, the easier you may find it to come to a settlement. But you don't want to cut it too fine, especially when you have a legitimate insurance claim. You are entitled to a first-class job, including replacement of parts that can't be properly mended. Anything less lowers the value of your car both while you keep it and when the time comes to trade or sell.

What are "necessary" repairs? In theory everyone agrees, but in practice there are almost sure to be some differences between insurance-company figures and your own. You may be able to negotiate some of them with the adjuster. If that doesn't work—and the argument is with your own collision company—your policy may permit

Do you need a lawyer?

THERE are at least two answers to this question. Insurance men point out that roughly 90 percent of all auto-accident claims are paid off without lawyers. But on the other hand a good attorney can almost always boost the settlement you'd otherwise get.

Whether he can boost it enough to increase your take-home pay is another matter. The lawyer who represents you in a damage suit or negotiation will probably work on what is called a "contingency" basis. Instead of charging you a flat fee, he'll take a percentage—generally between a third and a half—of what he can collect.

In a small car-damage case where there's a difference of, say, \$50 between what you ask and the insurance adjuster offers, there's not

much a lawyer can do. Even if he gets the full amount, you may end up with less.

But if the accident causes death, serious injury or substantial damage, it's usually wisest to have a lawyer press your claims.

The best time to engage him is right at the beginning so that he can protect your rights from the start, and gather evidence and interview witnesses while the events are still fresh.

If you need a lawyer, try to get one of the top accident men in your area. An experienced claims attorney will probably charge the same percentage as your brother-in-law's cousin who just got out of law school. But if he can take his cut out of a bigger pie, there will be more left over for you.

you to call in an independent appraiser. You'll have to pay half the fee and agree to accept his decision.

Claims under collision policies can usually be worked out without too much trouble, and payments are likely to be reasonably prompt. A major reason is that you're a customer as well as a claimant. To the liability adjuster, however, you are only a claimant and his primary job is to keep the settlement down—not to see that it's "fair" or that you get the best kind of repairs. He's well armed for the combat because he holds the purse strings. If you can't come to an agreement, you are free to call in a public appraiser—at your expense. The company need

not accept his judgment but such a step will probably strengthen your case if you decide to complain to your state insurance office—or sue.

Getting the job done right is up to you once an insurance company has approved the estimate of your repairman. So try to pick a good shop that will stand behind its work. When you're in doubt and time allows, it may be worth while to get two estimates before you even start negotiating with the adjuster. The estimate you agree on should detail each part to be repaired or replaced. When the job is done (or as it goes along) check off every item before you pay the bill.

Settling for injuries

Claims for injury compensation are obviously much more complicated than those for property damage. If you are hurt in an accident for which the other driver is responsible, his insurance company might reverse its technique and try to hustle you into a settlement. It's not uncommon for adjusters to rush helpfully to the scene with check-books poised.

The joker is that you can't collect partial payment; to get the check you have to sign away your right to any further claim. *Don't*. If there's any possible way you can manage your finances without accepting a quick settlement, hold off until you—and your doctor—know the extent of the injury and the recuperation time, and whether you may have suffered any permanent or recurrent impairment.

What's the current market price on injuries? If the case goes to court, there's no way of telling (which is one reason some companies favor the small-, quick-payment method). In-

urance men say ruefully that juries have been getting increasingly generous—and cite awards like \$86,000 for a broken hip and \$150,000 for a fractured back. These, however, are well above the average. You might get a lot less—or nothing at all. And, of course, stiff legal fees stand between the jury award and what you actually collect. In many states, moreover, it takes years for accident cases to come to trial.

So it doesn't automatically figure that you'll want to make a lawsuit out of your injury, especially if it's relatively minor. How much smaller is a negotiated settlement than what you might sue for? There are no set standards, but many experienced observers say that, as a rule-of-thumb, you will have little difficulty collecting three times your actual costs. For example, if a broken arm costs you \$300 in medical expenses, and another \$500 in lost wages, a claim for \$2,500 would probably be considered fair.

Experts recommend

that you keep these items in your car for use in case of accident:

- First-aid kit
- Flashlight
- Folding rule or tape
- A list of your insurance-company offices (supplied with most policies)
- Accident-reporting forms

On the following pages

Paper work after an accident is important for your protection. Do it while details are fresh and still available. Fill in the blanks on pages 10-11, and you can copy the data later onto the official report.

Checklist

YOUR CAR

FILL in the first three blocks now so the information will be handy when you need it. The other driver is entitled to data listed above the dotted line.

Make _____ Model _____ Year _____

License no. _____ Serial no. _____ Engine no. _____

Registration (if not in your name) _____

INSURANCE

Your company _____ Policy no. _____

.....

Your broker, agent, or company representative:

Name _____ Address _____ Phone _____

ACCIDENT REPORTS

(Check up now on local requirements)

State department to be notified: Motor Vehicle Public Safety
Police Highways Sec. of State Other _____

Minimum damage that must be reported: \$ _____ How soon? _____

City or county reports? _____ Forms available at _____

INJURED PERSONS

Names and addresses _____

Where taken? _____ How or by whom? _____

Doctor _____ Address _____

WITNESSES

(If possible, get names, addresses, license numbers or other identification. See page 3)

POLICE

(Check box at left if witness to accident)

Name _____ Badge _____ Precinct _____

Name _____ Badge _____ Precinct _____

B10 IF YOU HAVE AN AUTO ACCIDENT

Checklist

THE OTHER CAR

(If more than one car, get same data for each)

Driver's license no. _____ Name _____

Address _____ Age _____

Owner's name (if different) _____ Address _____

License registration no. _____ State _____

Liability ins. co. _____ Policy no. _____

Car make _____ Model _____ Year _____

Engine no. _____ Serial no. _____

Damage _____

OCCUPANTS

(List all; check box at left if injured or received medical attention)

Name _____ Address _____

Name _____ Address _____

Name _____ Address _____

Name _____ Address _____

DETAILS OF THE ACCIDENT

Date _____

Time _____ A.M.
P.M.

Weather _____

Street or road (note type of surface, wet or dry, straight, level, graded, etc.)

Any traffic control (light, stop sign, etc.)?

Were your headlights on? _____

Did you blow your horn? _____

Where and how? On diagram below, indicate streets, direction, where cars were, which way headed, distances from curb, etc. If necessary, draw your own diagram.

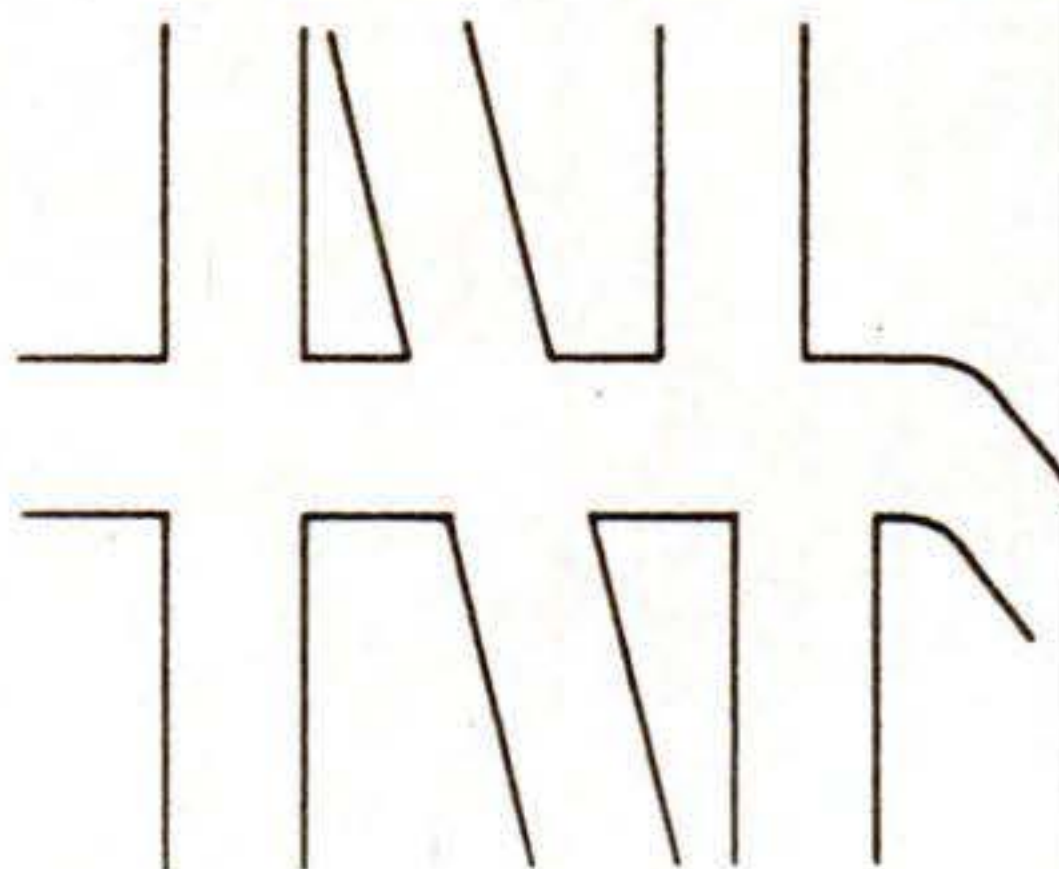

**P. S. EXTRA:
YOUR TEAR-OUT
BOOKLET NO. 10**

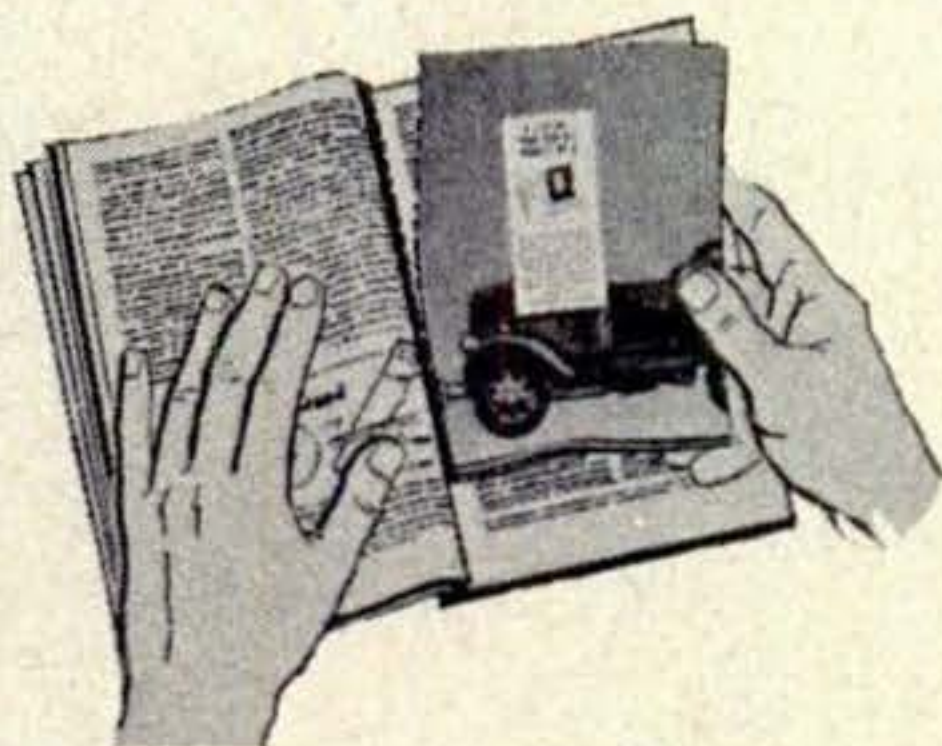

To remove this booklet, place your left hand on the facing magazine page, grasp the booklet with your right, and pull it gently away.

After you've read the booklet, put it in your glove compartment.

July 1958

POPULAR SCIENCE

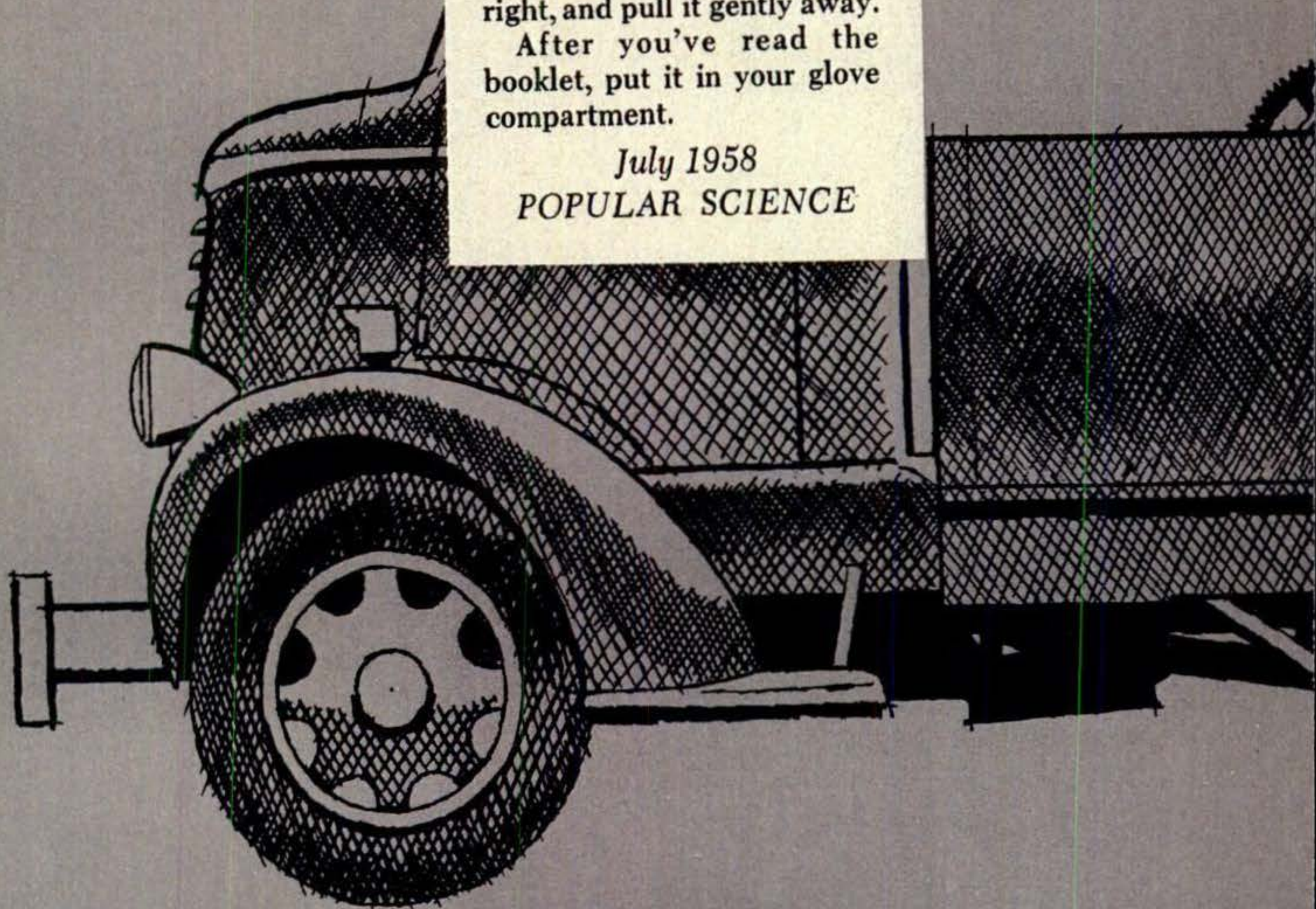

5 Tip-Offs to a Good Body Job

Checks used by pros tell you whether or not you're getting the first-class repair job that you asked for. The photos show you where to look, and what you should NOT find

1 Panel reflections

SIGHT ALONG THE SIDES of repainted panels. They should mirror objects without wavy distortions. Reflections like those pictured in inset (right) are tip-off to dents that have been poorly reworked or filled, if at all.

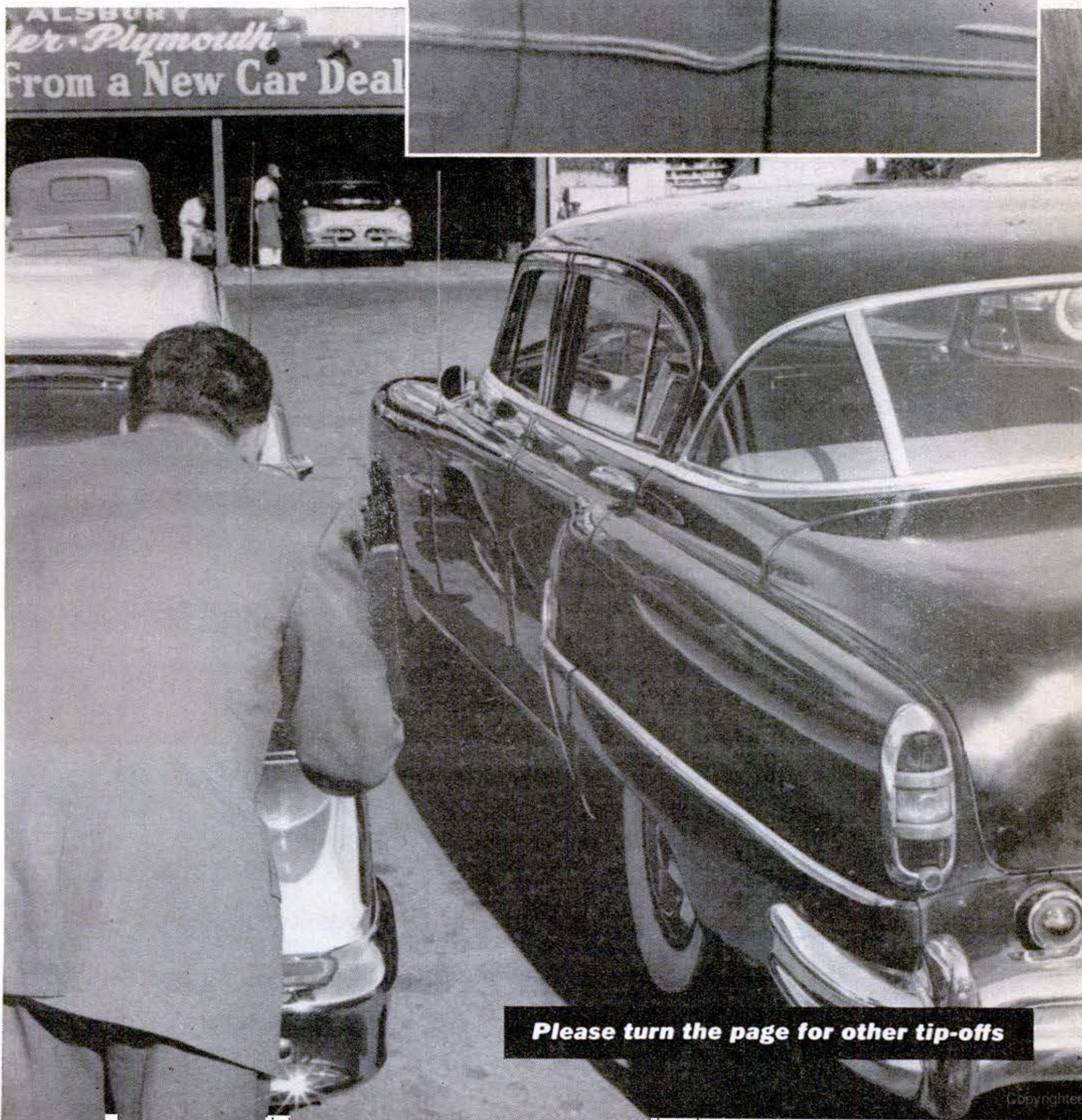
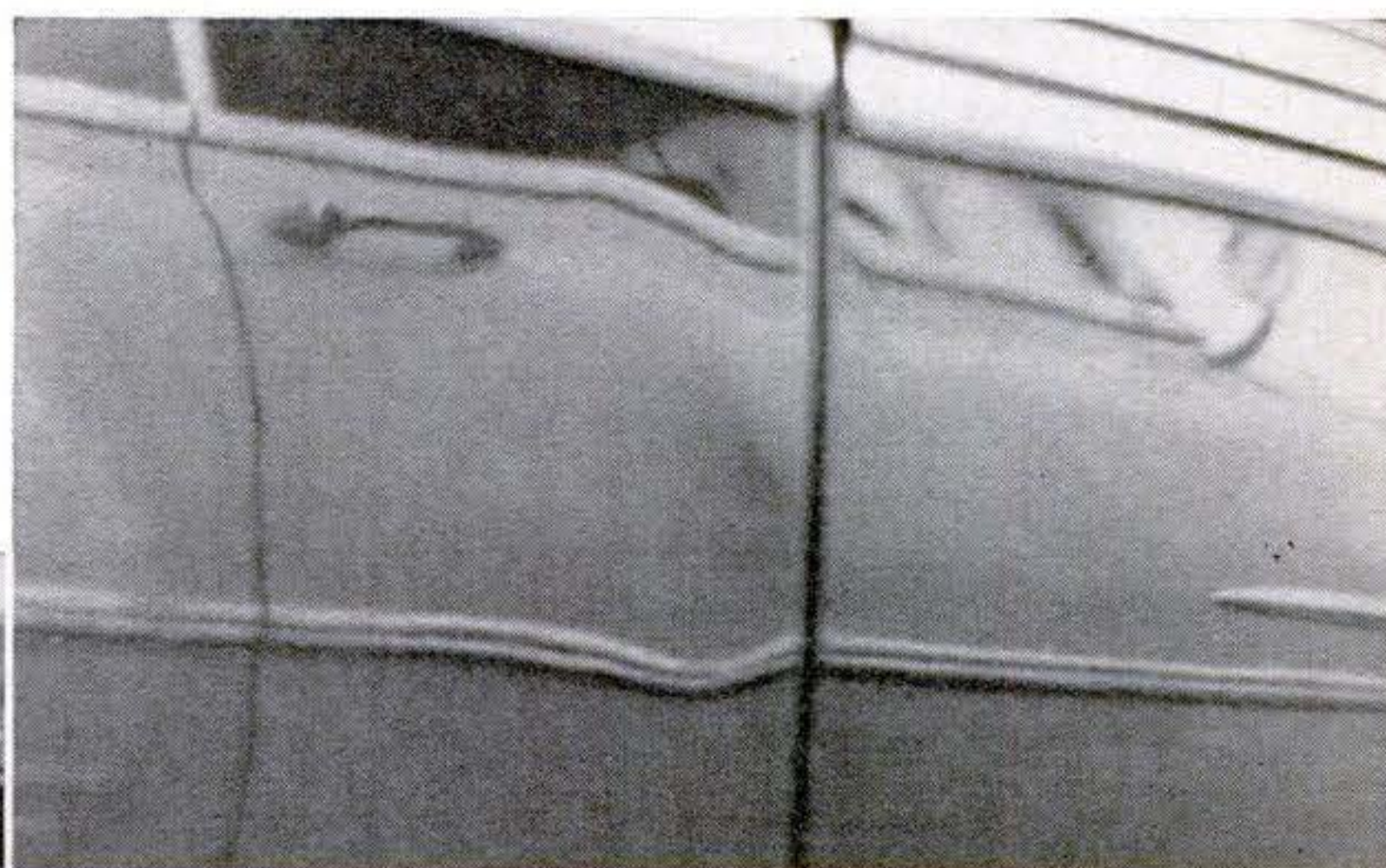

Please turn the page for other tip-offs

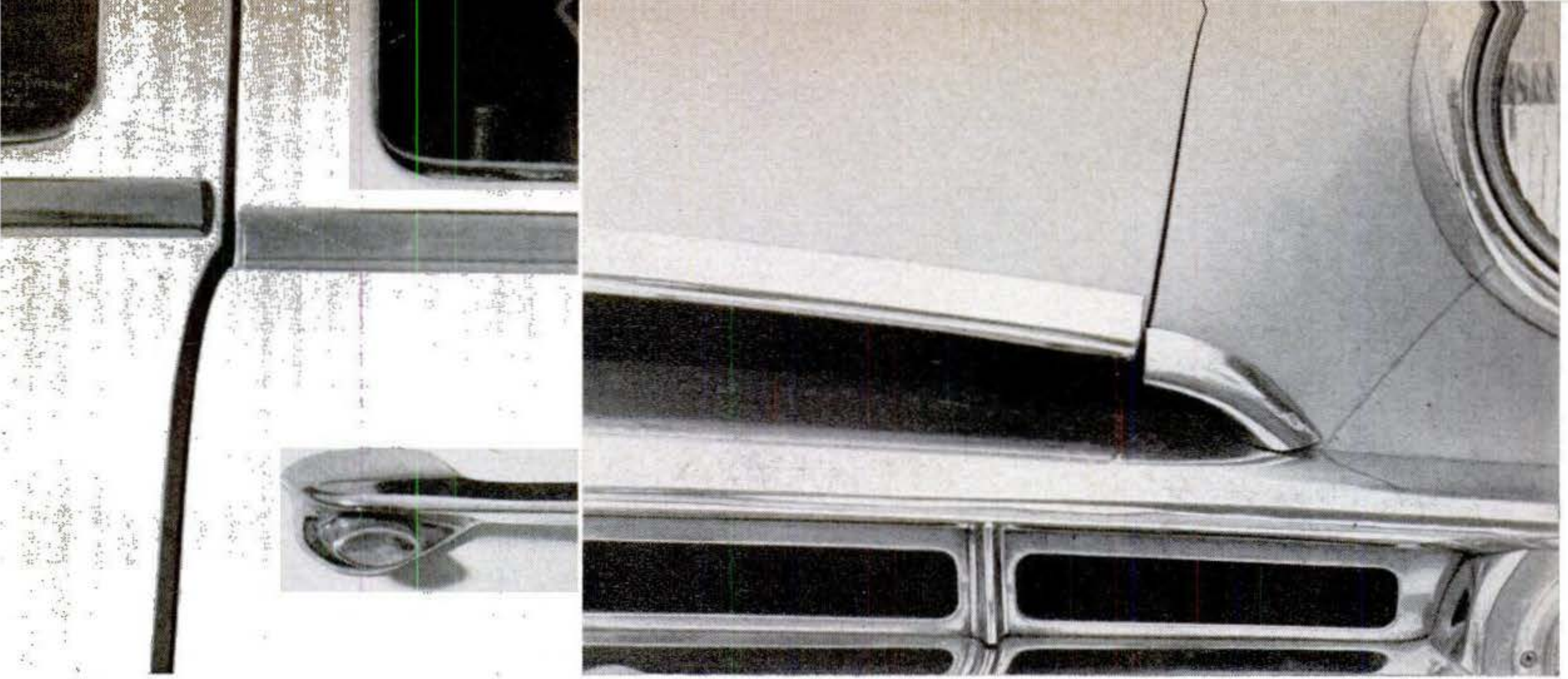

2 Trim alignment

CHROME SHOULD LINE UP, whether a door is hanging free or latched. In a good repair job the hinges are adjusted and the striker plate so placed that the up or down shift of the door is less than 3/16" when the lock engages.

LACK OF ATTENTION TO ALIGNMENT here, while not serious, is the stamp of sloppy body work. All chrome molding has adjustable clips or mounts, and the corner decoration should have been refitted to match the hood trim.

4 Chrome-work finishing



SCRATCHED AND BATTERED BUMPERS should be straightened out; in a first-class job they're also ground smooth and replated bright as new. Check for missing bolts; if a bumper breaks loose you may be in for real trouble.

SANDER MARKS THAT MAR CHROME, as below, also show that the trim was not removed, as it should have been, to get at adjacent peeling paint. Note sander marks on the new paint, too; body putty wasn't used to level them.

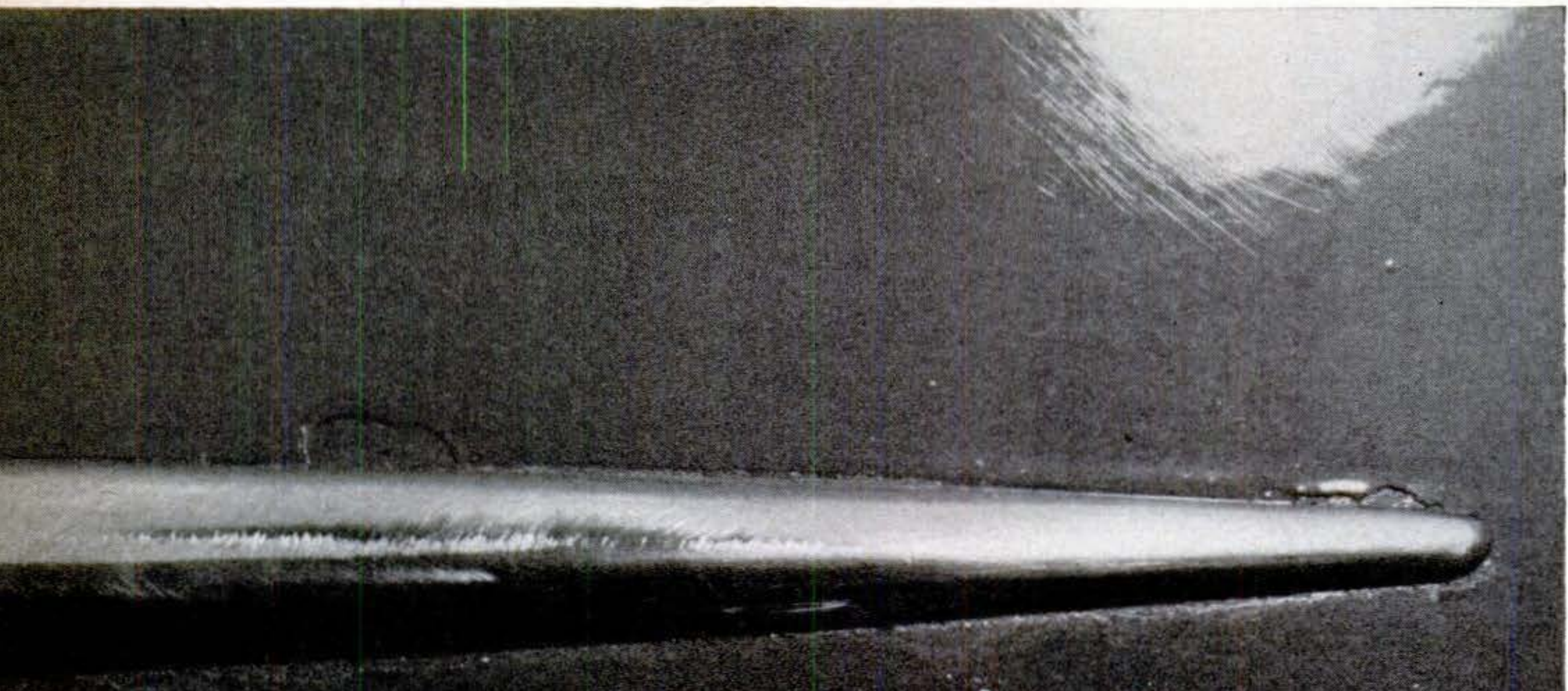

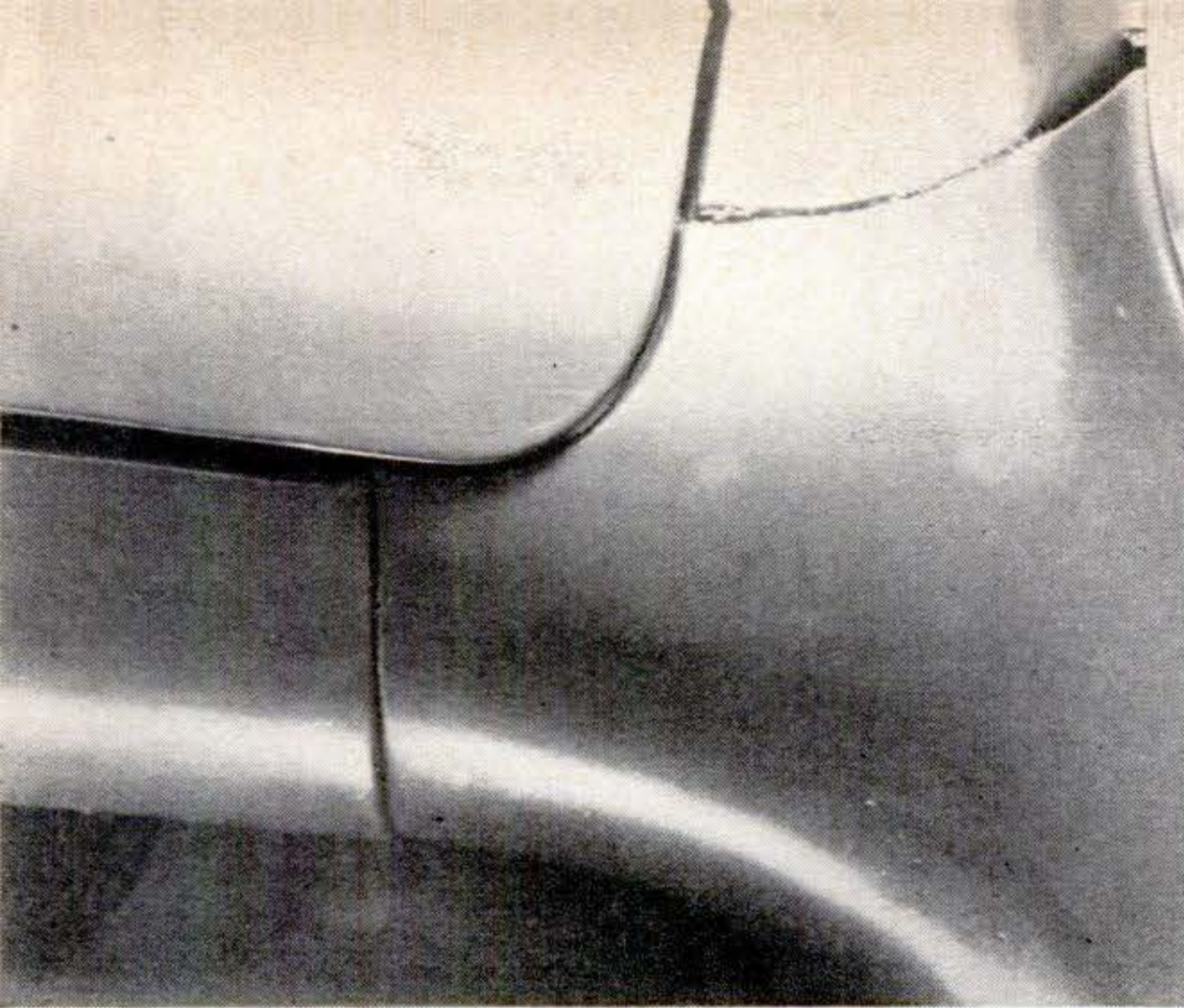

3 Seams and hinged joints

PANELS THAT HAVE BEEN TACK-WELDED out of alignment may prevent a hood or trunk lid from ever closing properly again. Wide gaps at the seams are an invitation to leaks and rust. Note poor body-putty work in the horizontal seam.



POOR SEAM AND HINGE FITS like these are inexcusable. There's a wide gap between the hood and the cowl, the fender has been placed too far forward, and the door has been rehung too close to the frame for adequate clearance.

5 Repainted areas

LOOK FOR CRACKS AND BLISTERS—they'll turn up quickly if the metal underneath was not properly prepared. Spots of grease or silicone polish, to which the new paint couldn't bond, account for the peeling surface on this car.

SPRAY GUN HELD TOO FAR AWAY from a reworked door panel produced the dull finish shown here. Except on old, weathered cars, you should expect an almost perfect surface match. That goes for color matching, too. **END**

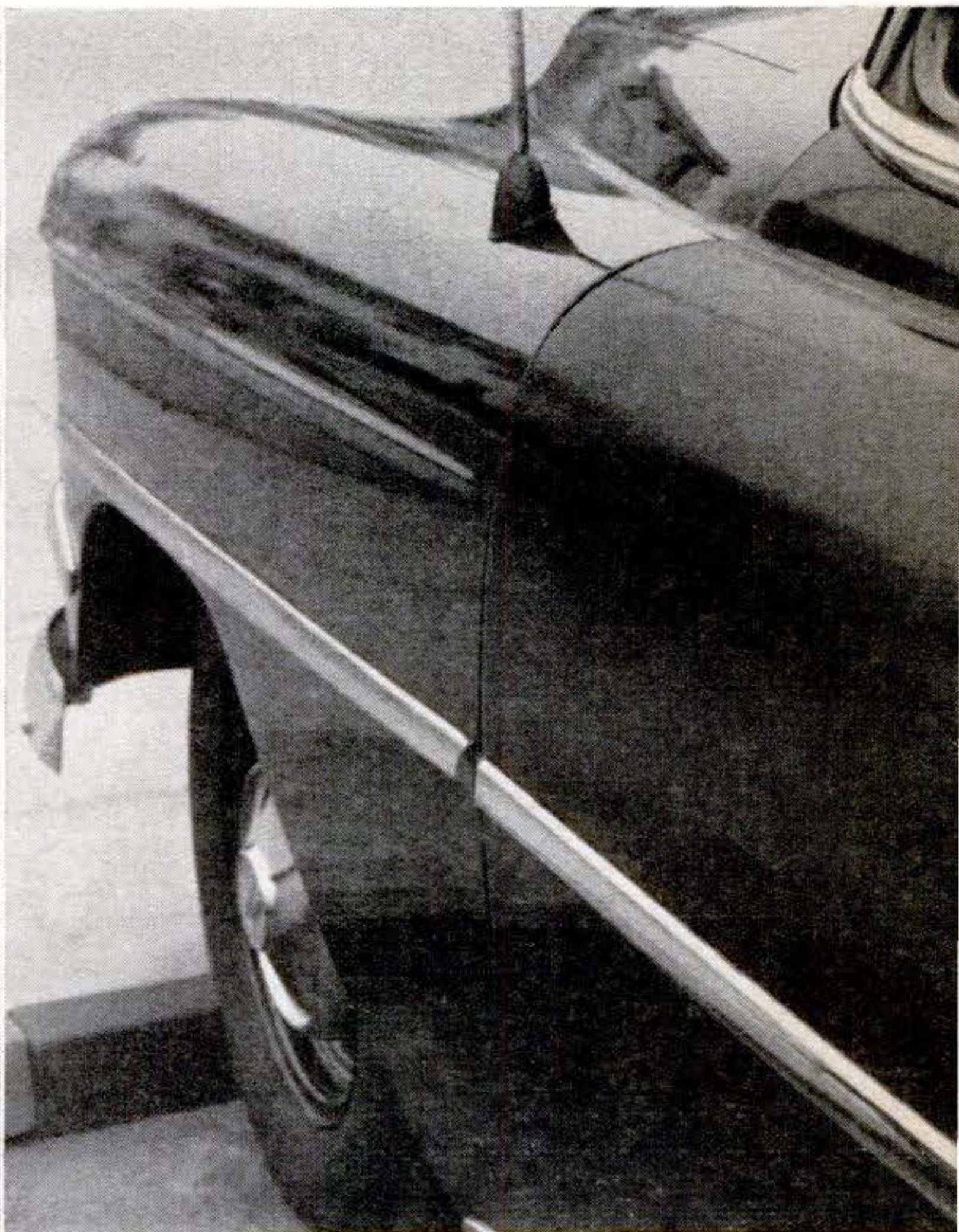



Stock cars streak around turn at Daytona Beach. In the past 5 years
Champions have powered 337 out of 353 NASCAR winners!

Q. Why do 9 out of 10 stock car winners
use Champion spark plugs?

A. Champions give full-firing power.
Put new Champions in your car every
10,000 miles. You'll get an *immediate* boost
in horsepower...and save gasoline, too!



*World's favorite spark plug—engineered for every car built by Ford, General Motors,
Chrysler, American Motors, Studebaker-Packard, and every major foreign maker*

CHAMPION

Pointers on Washing the Inside of a Car

By Herbert O. Johansen

"M A'AM, you've got the sweetest-smelling car in the neighborhood," said the garage mechanic, sticking his head out of the door of our car while he was making an adjustment on the turn signal.

A STICKY STEERING WHEEL can be cleaned in a jiffy when you have a suds solution handy.

My wife appreciates a compliment, but this was a new approach.

"Hope you didn't mind what I said," he apologized when the job was finished. "It's just that some folks keep their cars clean as a whistle outside where other people can see it, then forget the inside where they have to live with it." He shook

While you are at it, do the dashboard, door-knobs, handles, sun visor. Rinse and dry them.



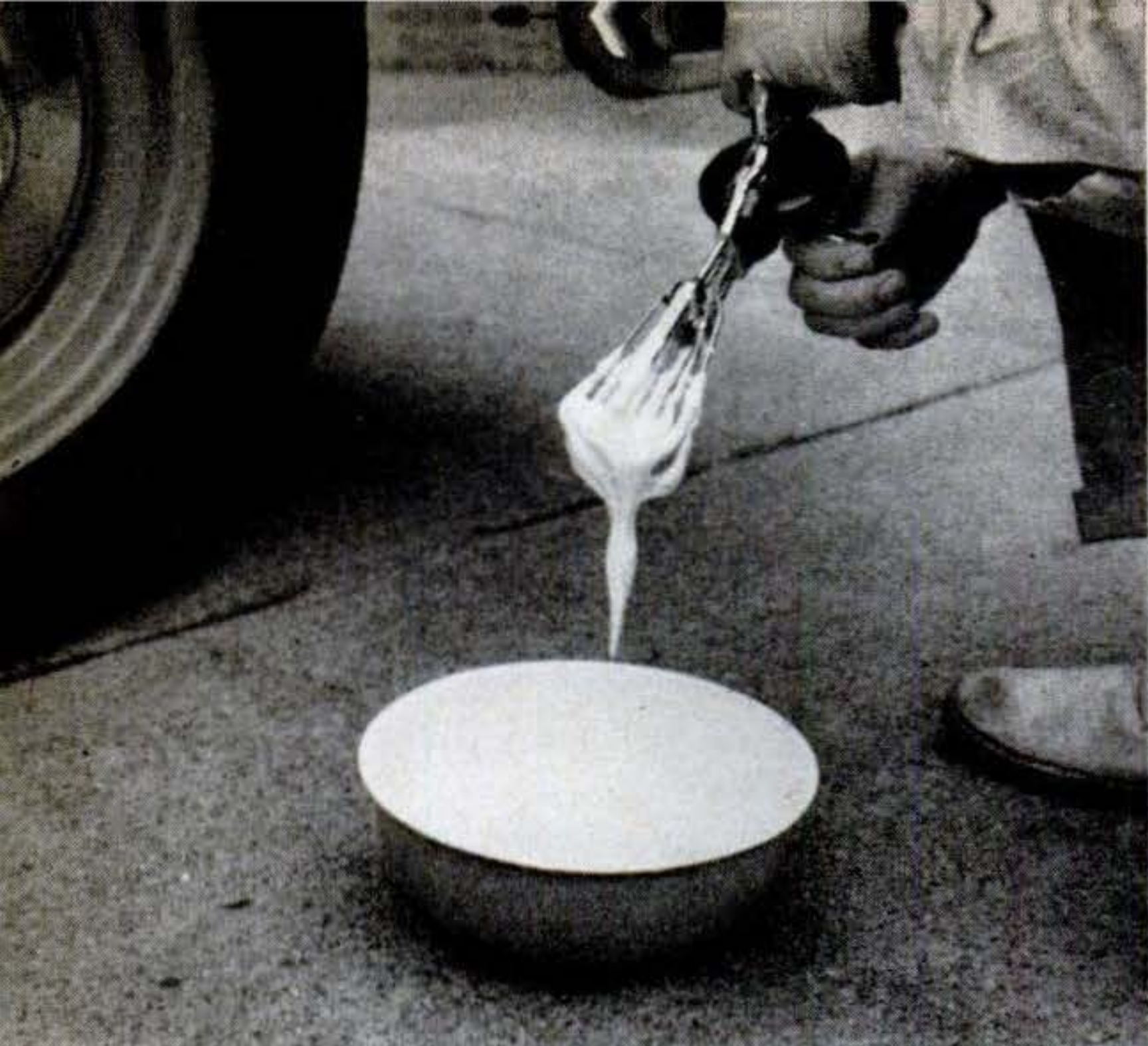

DRY SUDS are made by whipping up a good handful of soap or detergent in two tablespoons of water until you have a stiff lather about the consistency of a frozen custard.

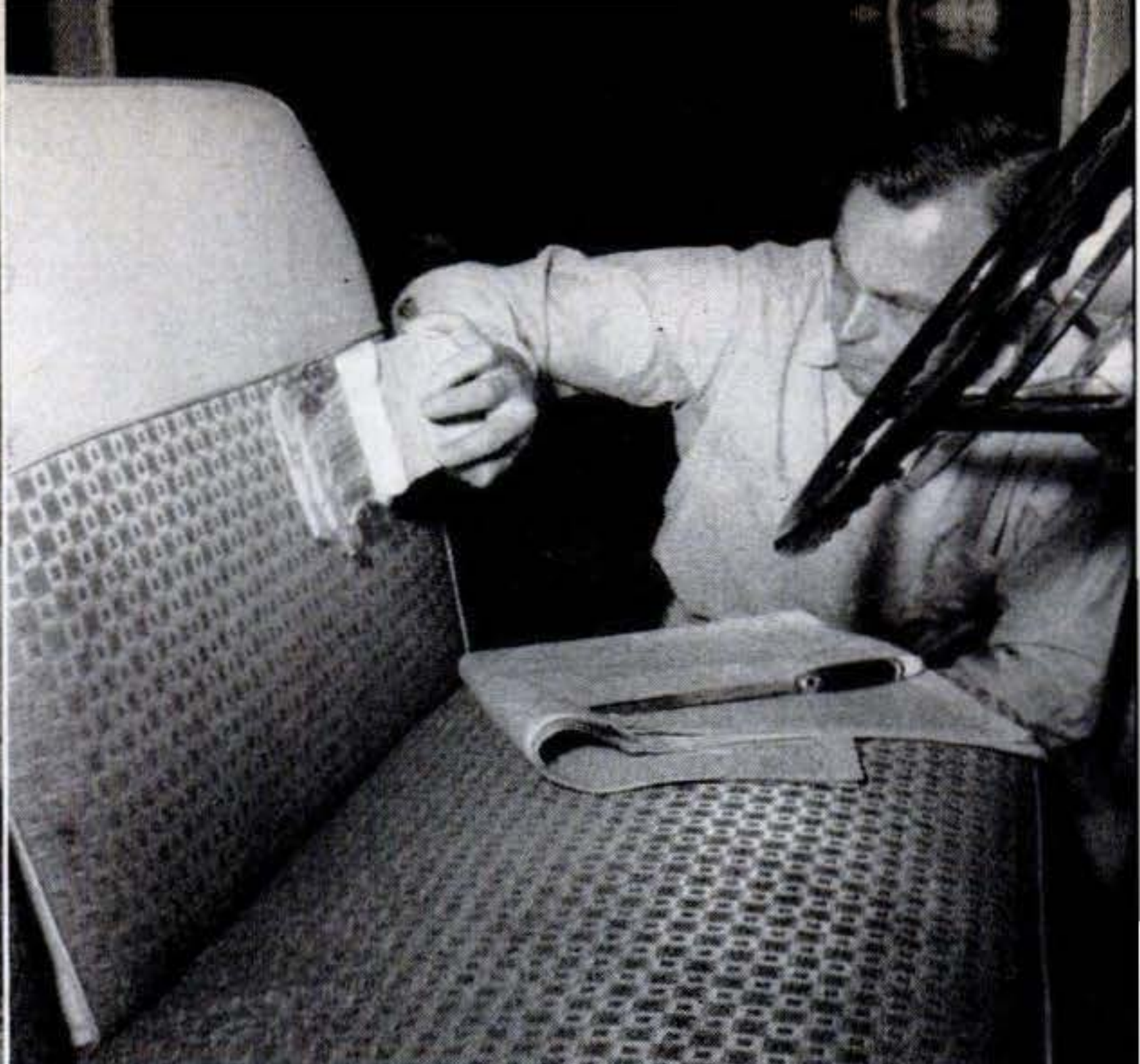

APPLY THE DRY SUDS to upholstery with a sponge, either natural or synthetic. Lay it on gently with the grain of the fabric, working small areas at a time. Don't rub suds in.

his head. "It doesn't make sense to me."

The inside of our car has been "clean as a whistle" ever since we realized that most of the interior of today's automobiles is covered with plastic or man-made fabrics that can be washed with plain soap and water or shampooed with "dry" suds. So now, when our car is due for a spit-and-polish job on the outside, we start by cleaning and washing the inside.

First we remove the plastic seat covers and vacuum the upholstery, cleaning up the rest of the inside while we are at it, brushing the floor and emptying the ash trays. The trunk gets housecleaned, too.

Then we go to suds, starting with the plastic ceiling. Using a sponge we apply a thick lather with a circular motion, doing small sections at a time, rinsing each with water and wiping dry. All other plastic surfaces get the same treatment.

Next comes the seat fabric, on which we use "dry-sudsing," as shown in the photographs above. Where the color has dulled, we have had good luck in restoring it by adding a tablespoon of ammonia to the suds.

(Warning: Do not use a suds-wash on felt or heavy-napped fabrics, which are apt to buckle. These should be cleaned with a special dry-cleaning solution.)

After that, we tackle the plastic seat covers, finish by giving the outside a thorough wash and polish—and we're clean, from the inside out.



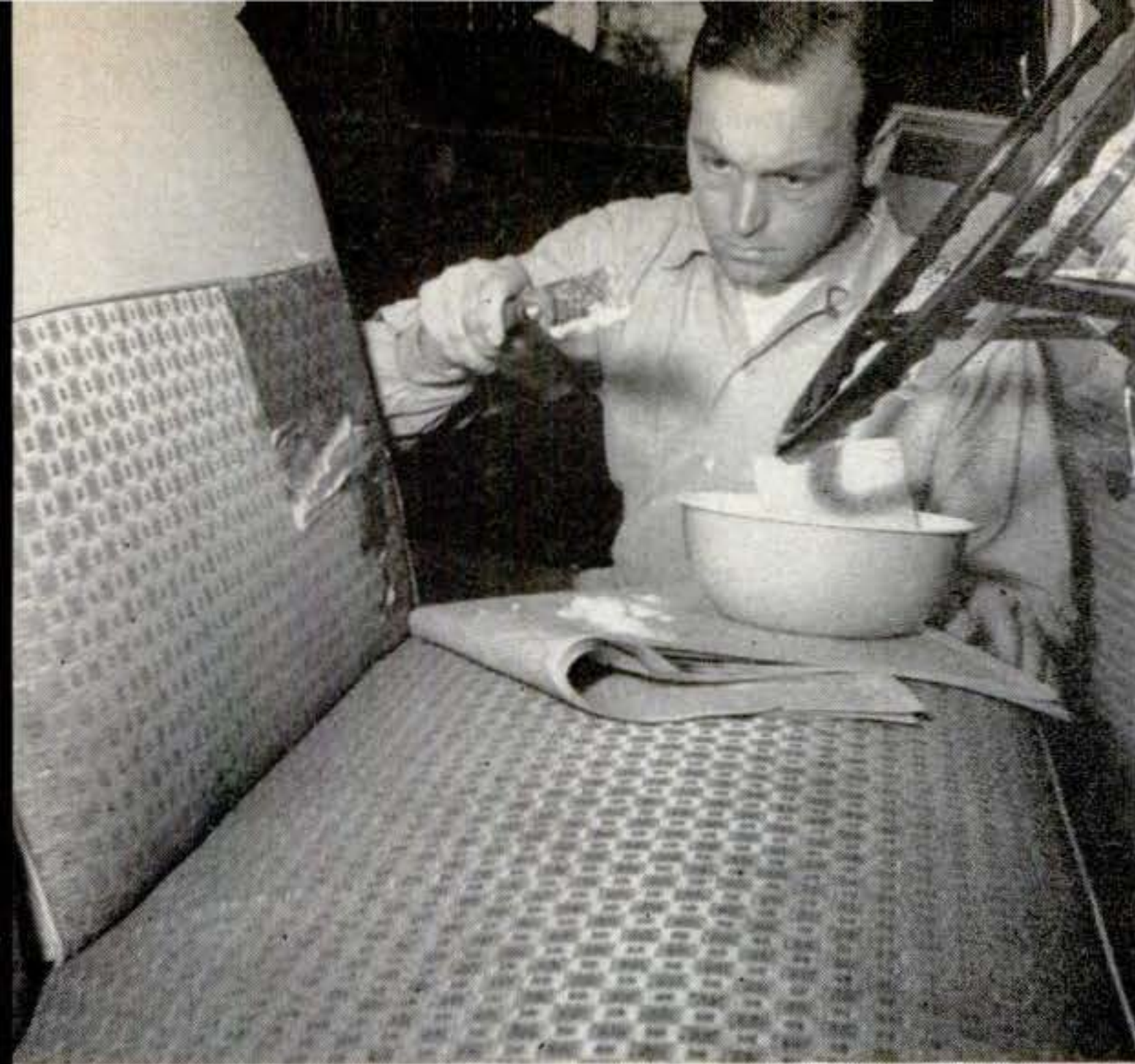

LEAVE THE SUDS ON for a few minutes to loosen and take up dirt. Then scrape off the lather with a spatula or the dull edge of a knife, and flick it off on a piece of newspaper.



WIPE THE AREA with a clean sponge that has been wrung out in clear water. When you work on the next section, overlap to prevent streaking. Don't use the discarded suds again.



WITH INSIDE OF CAR CLEAN and drying, the plastic seat covers get a soap-and-water bath while hanging on the clothesline. Then they are hosed down with clear water. **END**

Hints from the Model Garage

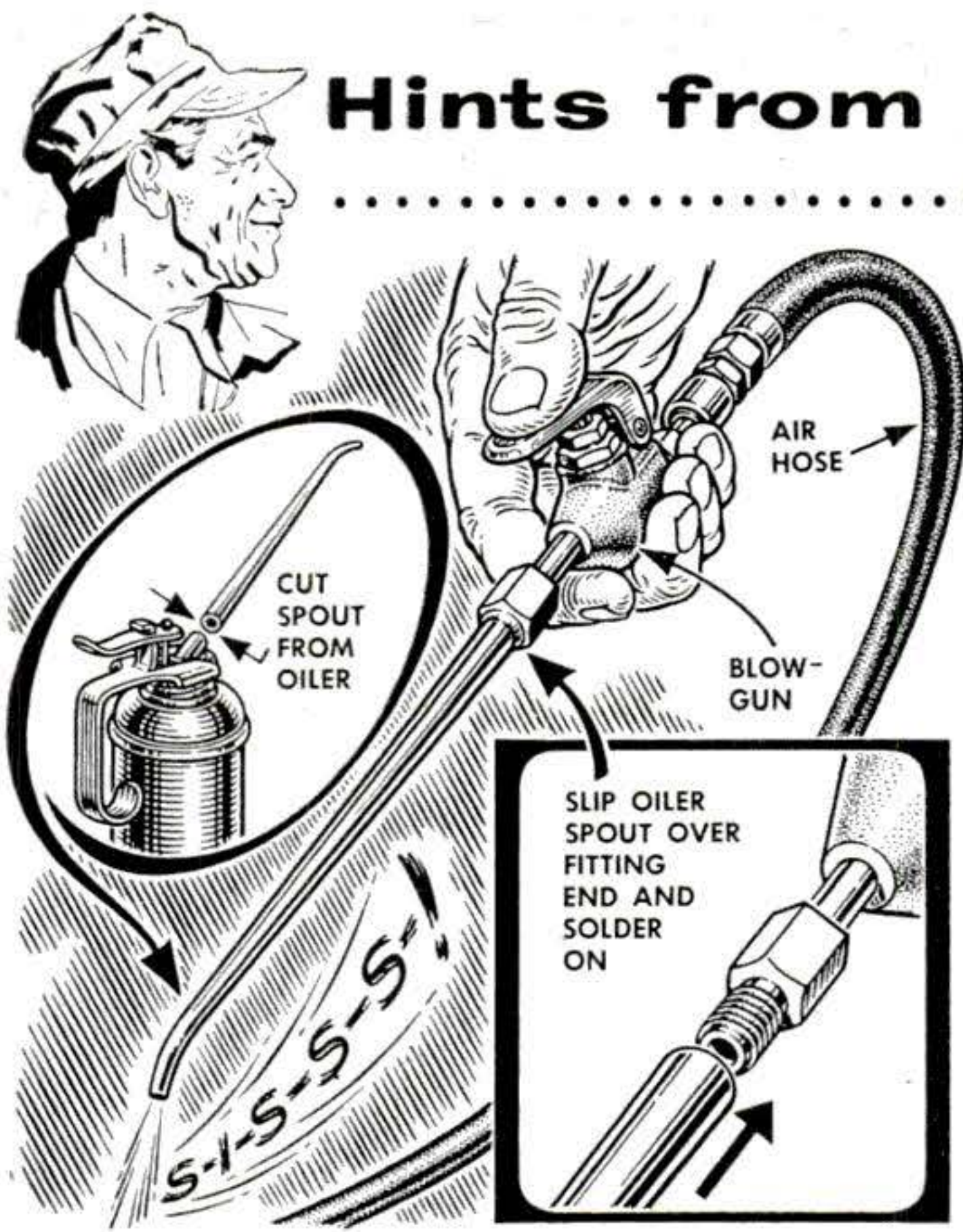

For blowing out dust from inaccessible places, solder the spout from an old oil can to a brass coupling that fits the blow-gun nozzle. You can then use the gun for normal cleaning operations and quickly attach the spout for a long reach.

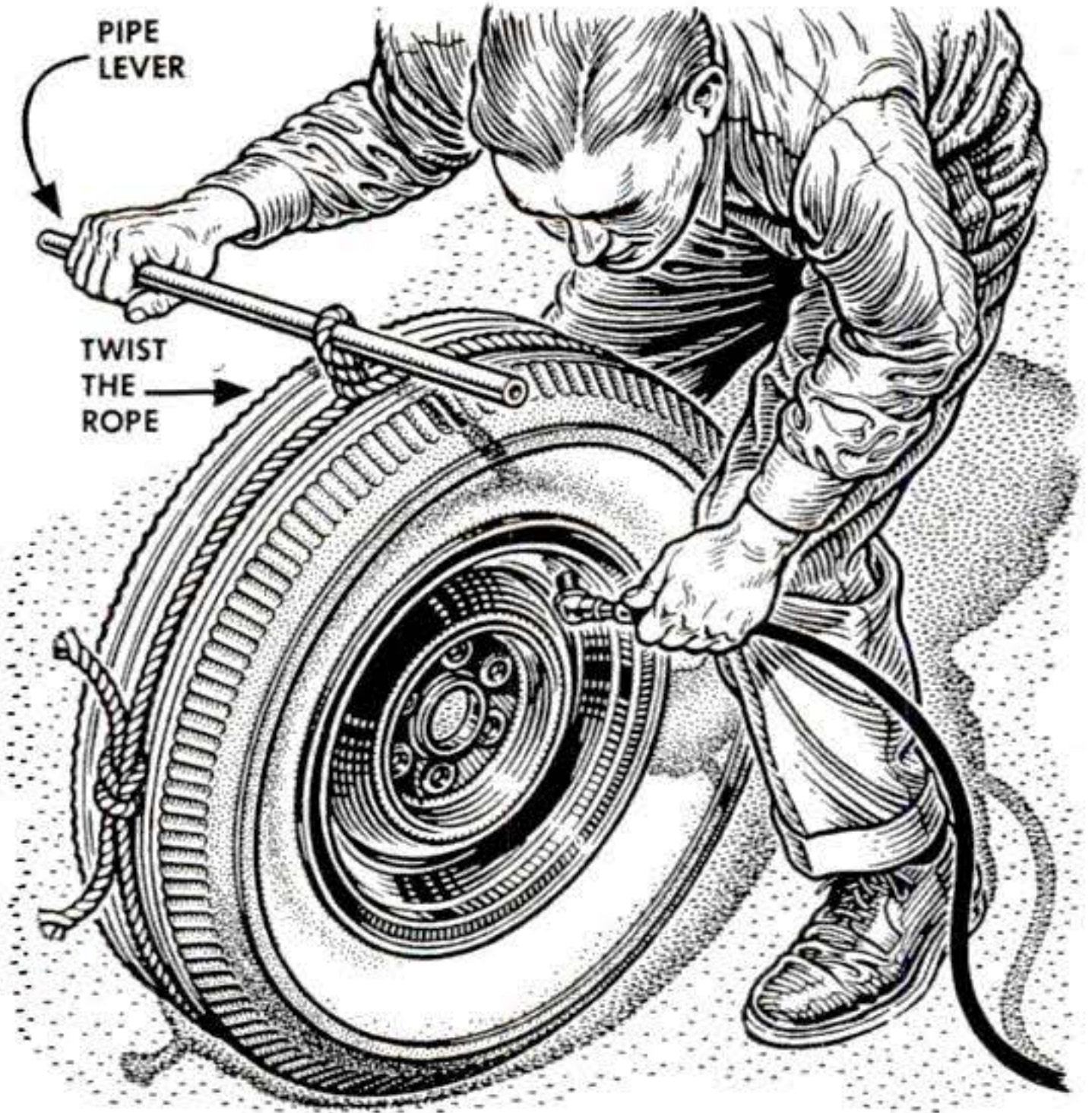

Repair your own tubeless tires? You can seat the beads against the wheel rim so they'll hold air by applying a rope tourniquet around the tire. When partial inflation expands the tire, remove the rope and inflate to recommended pressure.

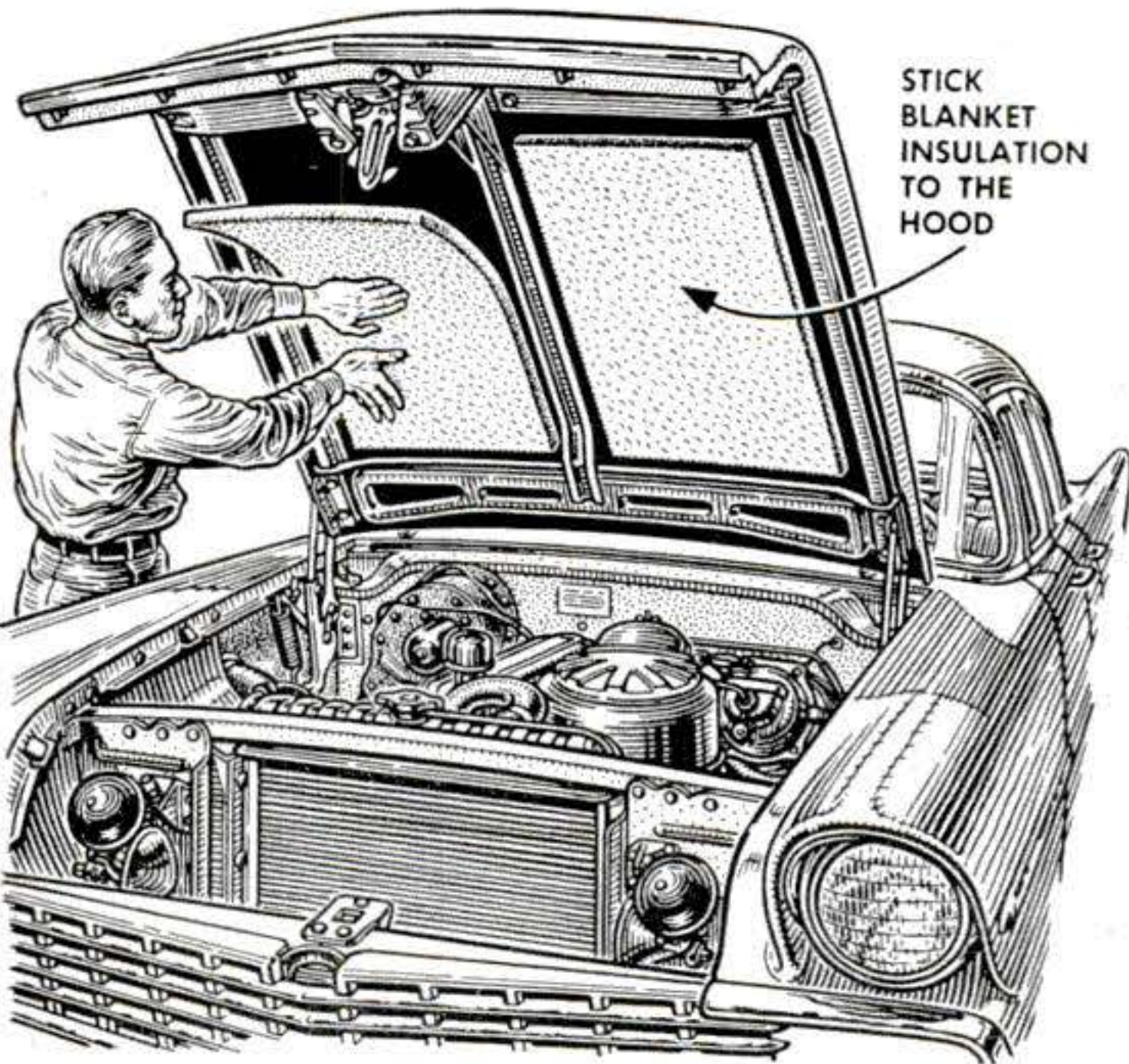

Make your own hood liner from blanket-type glass-fiber insulation sold by the yard at lumber yards. Cut the insulation to fit the underside of the hood, apply body undercoating to the metal, and immediately press the material in place.



To remove rust stains or chewing gum on upholstery one motorist uses cola drink and ice cubes. He soaks rust spots with cola, then shampoos the area after allowing it to act. Gum is hardened by chilling, then chipped off with a knife.



Hubcaps will stay new-looking if you remove them occasionally and wash and buff them. Use a lamb's-wool polisher in an electric drill to brighten the chrome, and finish off with a protective coat of paste wax buffed to a high polish.



Check the oil yourself? Keep your oil-pouring spout clean and ready to use by storing it in a plastic bag. Besides keeping dust and insects out of the spout, the bag will collect oil drippings, preventing a mess in the garage.

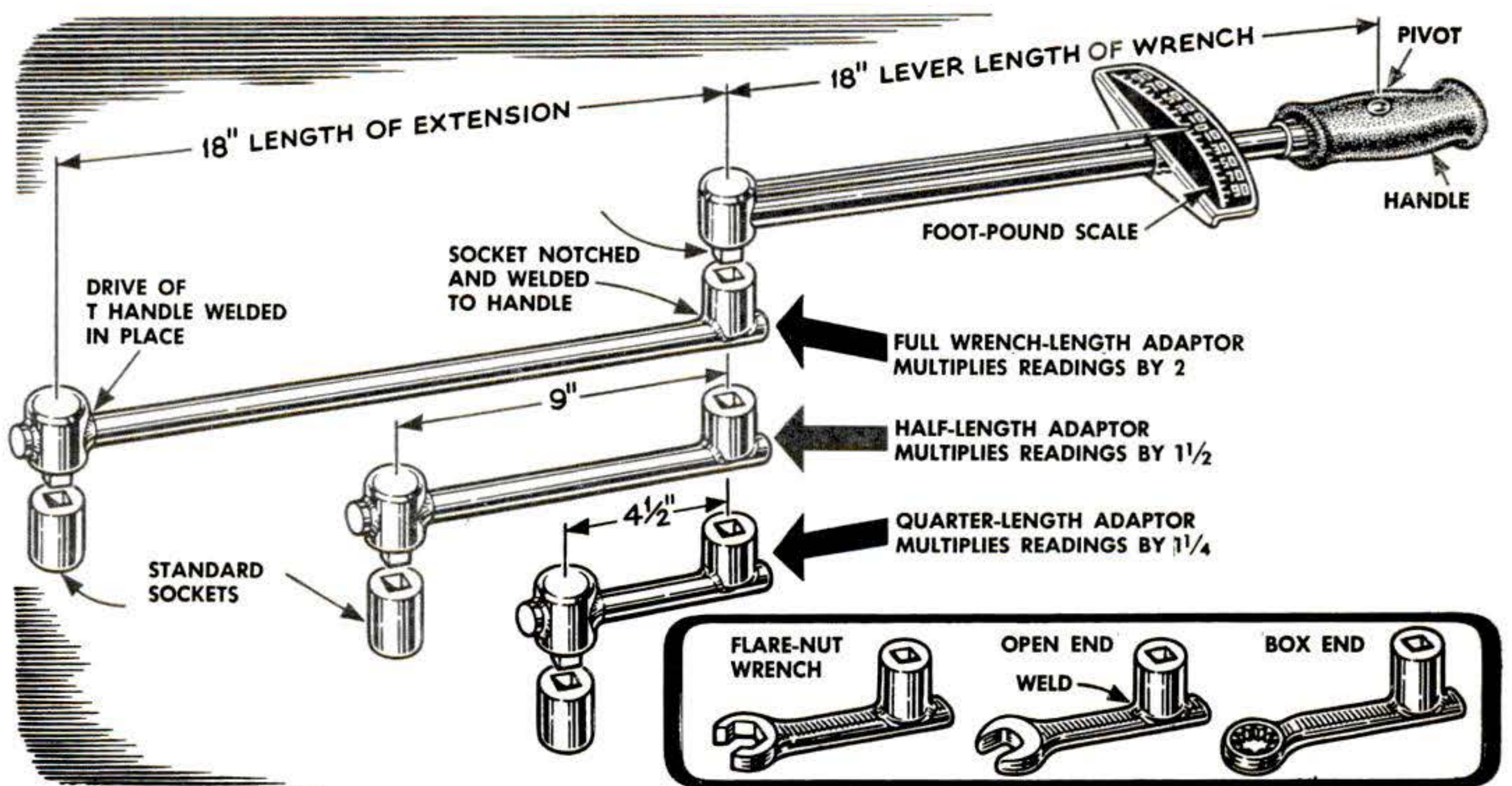

One torque wrench can be made to do the work of several. Just use wrench adaptors that can increase its capacity up to double the calibrations on the scale. An adaptor or extension arm equal to the lever length of the wrench will multiply the torque by

two; thus a 100-foot-pound wrench can be used to tighten bolts up to 200 foot-pounds. Shorter adaptors increase the range proportionately as shown. Adaptors with open or box ends (lower right) also extend the usefulness of the wrench.

Gus Faces a Low-Down Charge



By Martin Bunn

WHEN Verle Graham and Don Holt drove Don's middle-aged coupe into the Model Garage, their conversation wasn't intended for the ears of its proprietor, Gus Wilson. But, working quietly behind a car, Gus couldn't help hearing every word they said. A wry grin moved over his face.

"What kind of a sucker do you take me for, Verle?" Don Holt asked heatedly. "The service-station man said you owed me a new battery. You've known this old character, Gus Wilson, all your life. I don't know him from Adam's off ox. A fine break I'll get here."

"Just because Gus Wilson is a friend of mine won't make any difference," Verle retorted. "He'll be square with us both."

Gus slipped quietly from the far side of the car, moved around a couple of other vehicles, and stepped into view.

"Hello, boys," he said. "What's your trouble this morning?"

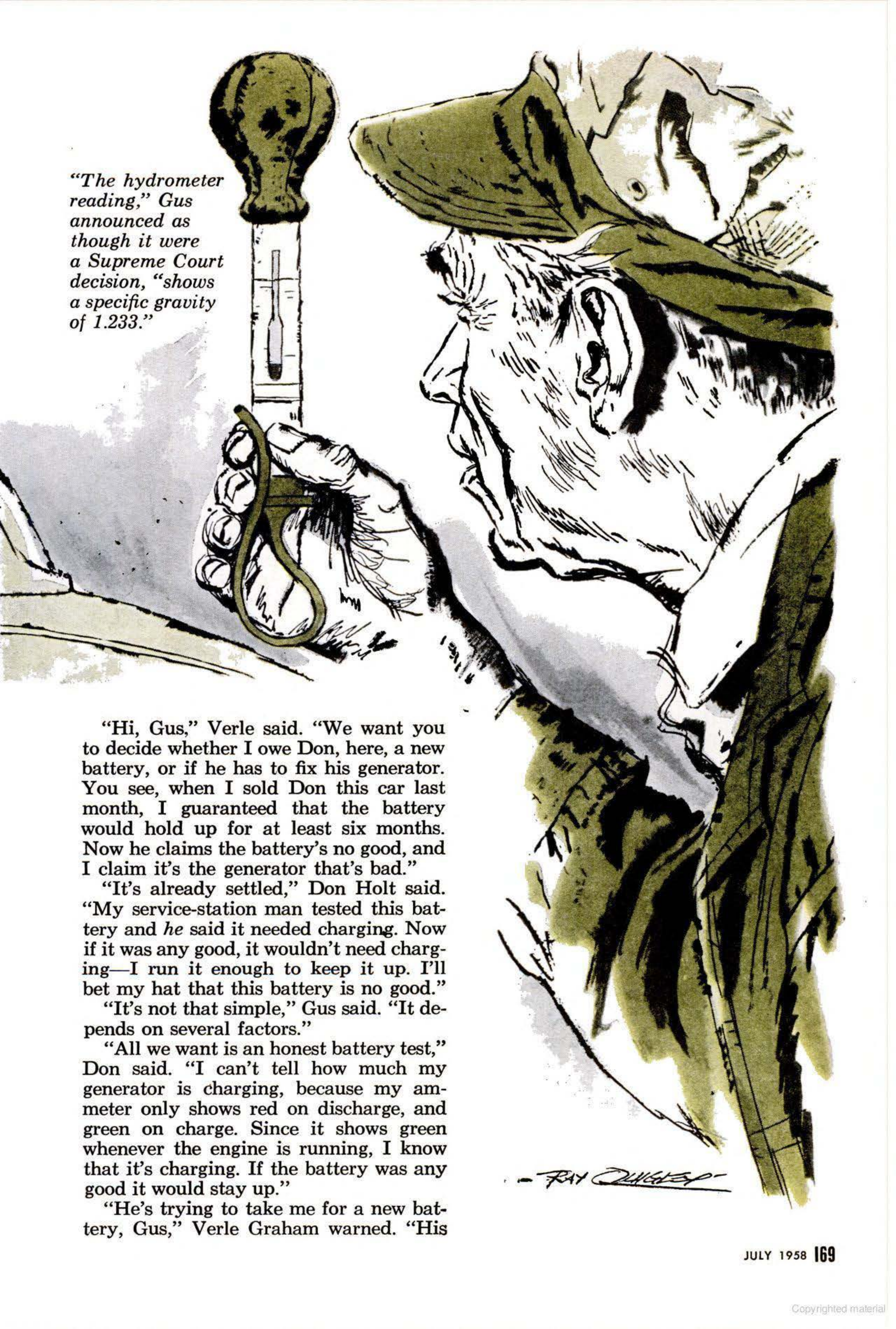

"The hydrometer reading," Gus announced as though it were a Supreme Court decision, "shows a specific gravity of 1.233."

"Hi, Gus," Verle said. "We want you to decide whether I owe Don, here, a new battery, or if he has to fix his generator. You see, when I sold Don this car last month, I guaranteed that the battery would hold up for at least six months. Now he claims the battery's no good, and I claim it's the generator that's bad."

"It's already settled," Don Holt said. "My service-station man tested this battery and *he* said it needed charging. Now if it was any good, it wouldn't need charging—I run it enough to keep it up. I'll bet my hat that this battery is no good."

"It's not that simple," Gus said. "It depends on several factors."

"All we want is an honest battery test," Don said. "I can't tell how much my generator is charging, because my ammeter only shows red on discharge, and green on charge. Since it shows green whenever the engine is running, I know that it's charging. If the battery was any good it would stay up."

"He's trying to take me for a new battery, Gus," Verle Graham warned. "His

pal at the service station said that a battery should have a specific gravity of at least 1.235. He claims this one tests only 1.233. Imagine, trying to stick a guy over two measly points."

"It isn't just a matter of two points low," Don Holt protested. "It's the fact that 1.235 is the lowest a good battery should get."

"You're getting me confused with this point business," Gus said cheerfully. "Let's get this straight. Your service-station man claims that your battery should have a specific gravity of at least 1.235 with a sound generator. Since it tests two points lower than this, you want Verle to back up his six-month guarantee with a new battery."

"Right," Don declared.

"I guess that's it," Verle said slowly. "If the battery is bad, I'll buy a new one—but Gus, you'll have to give me two or three months' credit on it. Right now I'm flat."

GUS winked at Stan Hicks as he got a hydrometer from the bench, thrust it into the battery, filled it, held it up to take a reading. He repeated this action in the other two battery cells.

"The hydrometer reading," Gus announced as though it were a Supreme Court decision, "shows a specific gravity of 1.233."

"There," Don said triumphantly. "With your own mechanic backing me up, Verle, you'll have to come to terms now."

"Not so fast," Gus said. "Since you two have put me on the spot as to who is going to pay for what, let's not jump to any hasty conclusions. This is a hot day, I'd say near a hundred in the shade. I'll bet the electrolyte in this battery is about that hot. You can't go by what a hydrometer tells you, unless the electrolyte stands at a true testing temperature of 80 degrees Fahrenheit. For every five degrees below 80, the hydrometer reading is false by two thousandths high. For every five degrees above 80, the hydrometer reading is off by two thousandths low, or as we call it, two points low."

"What!" Don's youthful features were indignant. "What kind of double-talk is this?"

Gus got a long, thin thermometer, thrust it into the battery, left it there a long minute and took a reading.

"The temperature of this battery's electrolyte," he announced, "is 90 degrees Fahrenheit. Since this is 10 degrees, or two fives, above a true testing temperature of 80 degrees, our hydrometer reading is four thousandths low. Therefore, the true specific gravity of this battery is 1.237."

"Holy cow!" Verle Graham exclaimed. "That lets me out, Gus."

"So that's why you insisted on bringing the car here," Don Holt said bitterly. "Nice deal, juggling figures and temperatures to beat me out of my battery guarantee. Wait till I tell the fellows out where I live about this. I'll bet my hat this garage won't get any more of their repair business."

"That's twice you've bet your hat on this job, Don," Gus said quietly. "I'm willing to give your battery a voltage and a breakdown test to prove my point. This battery is probably all right."

"Maybe," Don retorted. "But I'm not as dumb as I look. A battery can seem all right in all these tests, but still not be able to take and hold a full charge. Tell me, if this battery is all right, why won't it turn my engine over as it should? Why does my car start hard?"

"Maybe I'm wrong," Gus said calmly, "but I don't recall your mentioning any such troubles when you came in. Suppose you show me."

THE youth slipped behind the wheel, stepped on the starter. The engine turned sluggishly, didn't start until the starter switch had been held closed for more than half a minute. "I suppose you call that a good battery," Don said.

"I'd call that a badly worn bushing in the rear housing of your starter assembly," Gus replied.

"Starter assembly!" Verle crowed. "Do you mean to tell me that the trouble isn't in the generator at all?"

"And why not?" Gus asked. "Don said that the ammeter showed green when the engine was running. When I took the caps from the battery cells I could see bubbles rising in the electrolyte, which indicated that the generator was throwing a good charge into it when you drove in here. From the sound of things I'd say that the starter is running in a bind from a bad bushing, letting the armature strike the field coils with every turn. This robs the

Special Delivery!

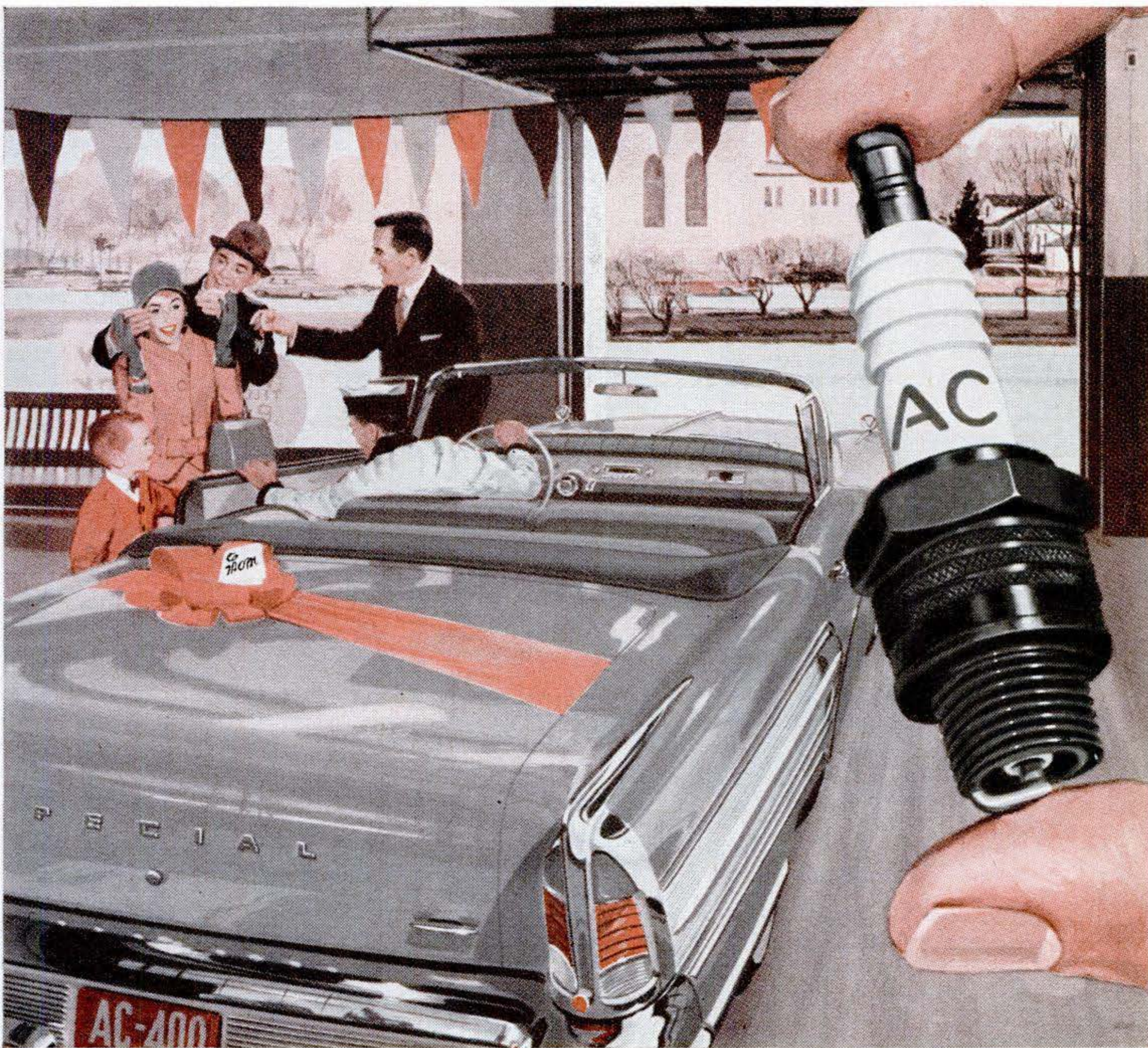

1958 BUICK SPECIAL CONVERTIBLE ILLUSTRATED

A new set of **AC** Hot Tip Spark Plugs can deliver savings up to three times their cost

When your GM car comes off the production line you will find either six or eight AC Hot Tip Spark Plugs under the hood. As a matter of fact ACs are the manufacturer's original equipment choice for more new cars than any other. Make them your choice for replacement, too.

If the spark plugs in your car have delivered 10,000 miles or more of service, they're due for a change. And, a change to ACs can save you up to one gallon of gasoline out of every ten. This is because the AC Hot Tip burns away carbon and oil deposits. ACs are factory-installed on more new cars than any other make. Have them installed in your car, too!



AC SPARK PLUG  THE ELECTRONICS DIVISION OF GENERAL MOTORS

ACTION
starts with



HOT TIP
SPARK PLUGS

Watch Walt Disney Studios' ZORRO
every week on ABC-TV

JULY 1958 171

primary ignition circuit of juice, producing hard starting. With this engine taking so long to start, it would take a pretty good battery to hold up to even where this one is, with the kind of stop-and-go driving most of you young fellows do. Here, I'll show you."

SWIFTLY Gus removed and disassembled the starter. He removed the rear casting, drove out its armature-shaft bushing, installed a new one, ran a reamer through it, reassembled and installed the unit.

"Try it now," he said.

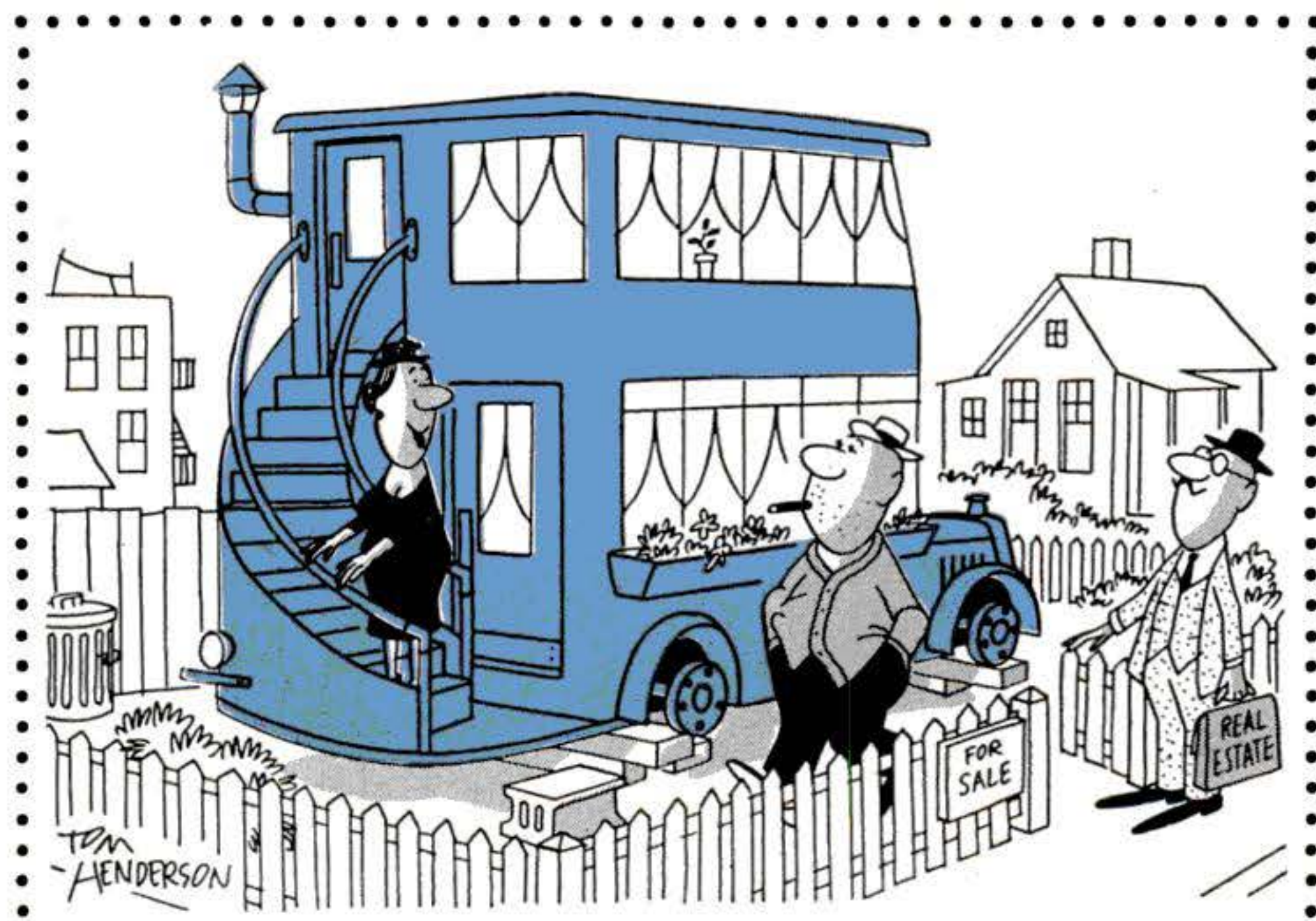

... And, honey, look at the lovely spiral staircase!"

This time when Don stepped on the starter, the engine fired instantly.

"Well, I'll be darned!" Verle exclaimed.

Gus dug out his pipe, filled it and lit up. "You boys sort of put the cart before the horse when you came in here," he said. "You didn't ask me to tell you what was wrong—you told *me*. You asked me to judge between a bad battery and a bad generator. Next time, tell the mechanic your troubles and let him do his own thinking."

THE way it turns out," Don Holt said slowly, "is that I have to pay for fixing the starter. How much do I owe you, Mr. Wilson?"

"Well," Gus said, "there's just about enough rubbish piled behind the garage to fill the rear deck of this coupe. Tell you what I'll do. If you'll haul that rub-

bish to the city dump on your way home, I'll call it square. Does that sound fair?"

"It sure does," Don said enthusiastically. "I guess I was wrong about you, Mr. Wilson, just like Verle said I was when I got to shooting off my mouth."

"After all," Gus said, and his eyes twinkled, "you didn't know me from Adam's off ox."

Don Holt's face reddened. "I'll bet he heard every word we said when we first came in."

"Who, me?" Gus said. "Why, an old character like me can't hear anything."

"What I keep asking myself," Stan

said, after the boys had left, "is what condition you would have said that battery was in if this had been a zero-weather day, with the electrolyte standing at, say, 35 degrees, and the battery showing a hydrometer test of 1.233, as this one did."

"In that case," Gus commented, "I'd have had Verle Graham on my credit books for a new battery. Even though I was sort of kidding the lads along, this temperature business in a battery test is really the straight goods. A battery with

a specific gravity of 1.233, on a normal hydrometer reading, with the electrolyte standing at 35 degrees, would have an actual, corrected reading of 1.215—which would really be a dead one in the eyes of those youngsters."

"Those kids had you in a bind," Stan said. "I was wondering how you were going to squirm out of it without getting one or the other sore at you. I never saw you use a thermometer on a battery test before."

"I never found myself arguing two points of specific gravity before," Gus said. "With the decision hanging on such a tricky technicality, I felt that I'd better get just a little bit technical myself, that's all."

"Well, you sure did, Professor Wilson," Stan chuckled. "You sure did." **END**

Next month: Gus teaches fair play.



"Hast thou found me, O mine enemy?" shouted the struggling man.

A bomb scare at the airport lends drama to a fix-it job involving

TV's Big Troublemaker Circuit

By Art Margolis

WHEN your TV set acts up, the tube most likely to need replacement is the horizontal-output tube. Even if the trouble isn't tube failure, the horizontal-output circuit is still a frequent source of trouble. The reason is simple—it's the hardest-working circuit in the set.

Most circuits do just a single job. The horizontal output is loaded down with other tasks besides the one from which it gets its name—spreading the picture sideways. It provides:

- Synch pulses that are fed back to a circuit that keeps the

TALES OF A TV REPAIRMAN

horizontal oscillator in step with the transmitted signal.

- Keying pulses for the automatic gain control.

- Energy for the high voltage that gives screen brightness.

- Filament voltage for the high-voltage rectifier.

- Bias voltage, in more recent sets, for the vertical-output circuits.

Because of these many duties, trouble symptoms can take as many guises, making it tough on the repairman.

THERE'S one case I'll never forget. I was working on a set at our airport when two terminal guards escorted the wild-eyed mad bomber through the passenger lounge. He was shouting, "Hast thou found me, O mine enemy?"

An assistant manager came over and told me about it.

"Caught him trying to smuggle an infernal machine aboard Flight 107," he said. "Dropped his suitcase going up the steps and it broke open. 'That's not mine! Where is the Word?' he yells." The manager snorted. "The Word! You should have seen the tubes and wiring in that bag!"

I was shocked, remembering the headlines after a recent mid-air time-bomb explosion that had killed more than 40 people. The man looked like a Hollywood version of a villain, all right. He had been watching me until his flight was called. When he left, he was quoting the Bible at me, something about "Remember the end and thou shalt not go amiss." Well, it was none of my business. I shrugged my shoulders and went back to tinkering with the set.

"How's it coming?" asked the manager.

"Should have a picture for you in a minute," I said. When I had first turned the set on there was a picture, but it was like pulled taffy at one side and folded over at the other, with a fat white streak down the center.

It was an extreme case of horizontal foldover, in which the horizontal sweep signal—a voltage that rises and falls—is distorted. When viewed on an oscilloscope, this voltage, delivered by the horizontal-output circuit, is sawtoothed.

The output circuit takes a small saw-

tooth voltage and amplifies it for horizontal scanning. From the output circuit, the amplified saw is matched into the horizontal yoke, and the varying voltage induces a varying magnetic field around the yoke. Since the yoke is mounted around the picture-tube neck, it affects the cathode ray. The moving magnetic field pushes the cathode ray in sawtooth fashion, scanning from left to right, slowly, then whipping back to the starting spot to scan the next line.

As long as the sawtooth retains its shape the horizontal cathode-ray scanning takes place normally. In this TV, however, the saw shape had become distorted, and the messed-up sweep was causing horizontal foldover.

Starting with a voltmeter check of the horizontal-output stage, I found low voltage on the screen grid—30 volts instead of 200. Somewhere 170 volts were missing. Since the voltage had to pass through the 8,000-ohm screen grid resistor, I turned off the TV and measured it. The ohmmeter needle read 300,000 ohms! This resistor had increased in value, absorbing the missing 170 volts. I had been replacing the faulty resistor when the bomb excitement broke out.

"That should do it," I said to the assistant manager, making a final adjustment and switching the set on. The screen filled with a sharp, clear picture. "Your troubles are over."

"That's what you think," he said as we heard the screeching of police-car sirens. "Want me to help you move the set back in place?"

"Wait till I check the tubes." It wasn't really necessary. I guess I just wanted to show off my pride and joy, a homemade tube checker. I pulled over the old suitcase in which it was mounted and released the catch.

"Say," the manager said, "that's just like the suitcase that man . . ."

He stopped and we both looked down. Out of my open suitcase spilled a mess of literature—religious tracts. Then I saw a printed identification tag pasted inside. I was on my feet and dashing madly across the passenger lounge.

"Stop!" I hollered. "Hold everything! He's innocent! That's my tube checker he's got!"



I Outsmart Myself

MR. AND Mrs. Mercer taught me a lesson. When he opened the front door of the big house to my ring he kept it on the safety chain until I had introduced and identified myself. As I stepped into the entrance hall a mousy little woman darted behind his back: Mrs. Mercer. They were both very young.

"We're sorry to trouble you," he apologized, "but our TV set has been getting worse and worse all week."

"Why didn't you call me before?" I asked. "TV trouble is my business."

"Yes, sir," said Mr. and Mrs. Mercer in toneless unison.

I spied a 21-inch set in a parlor off the hall and, without waiting for an invitation from my shy pair, I went over and turned it on. The picture came in fine. Then a black border appeared, and, as I watched, the picture shrank until there was a three-inch border all around. Suddenly the picture blew up like a balloon, dimmed, and finally darkened.

"Mr. Margolis," came a timid voice, "there's something I want to explain . . ."

"Nothing to explain," I said. "You two just relax. I'll take care of everything."

The couple went into a whispered conference as I began to examine the set.

Before turning it off I noticed that the plates of the horizontal-output tube were cherry red. That gave me a clue.

One function of the horizontal-output circuit is to provide 10,000 volts. This acts as an attraction voltage, which pulls the cathode ray against the phosphor screen to cause light. When this voltage is low, it loses control of the cathode ray, the sawtooth sweeps too far, and the picture appears to bloom.

With the set on again and my voltmeter probe on the horizontal-output screen grid, the meter read way above the prescribed 200 volts before the set even warmed up. Then it dropped down to a 150 reading. I diagnosed the trouble as a shorted screen-grid resistor. This caused extra current drain, which also lowered the efficiency of the entire set, resulting in shrinking and blooming. Sure enough, the resistor measured 400 ohms instead of its prescribed 10,000. A new resistor made the fix.

"There you are, good as new," I said.

"The landlady will appreciate that," said Mr. Mercer.

"You see," added Mrs. Mercer, "we only board here. The TV set we called you about is a portable one in our room."



How I Got a Trimming

MY FRIEND Hank Bagley now lets out a wolf whistle every time I come into his TV-parts store to place an order.

It began in the beauty shop across the street. I had been called in to repair their TV set, and thinking to kill two birds with one stone I stopped at Hank's store first. As it was near his closing time, I told him to bring my order across the street to me when it was ready.

At the beauty parlor I found a TV picture that was stretched out too far vertically (giving the performers pointed heads and sawed-off legs) with a fold-over at the bottom. Looking at it gave me the willies.

The symptoms were familiar, but in this case I traced them to a new cause. There is a sawtooth voltage in the vertical output as well as in the horizontal. It is 60 cycles a second instead of the horizontal's 15,750.

If this sawtooth voltage becomes distorted, it can cause a foldover—but up-and-down rather than sideways. Usually the trouble is caused by a defect in the vertical circuitry. But not this one. Here, due to a new circuit arrangement, a de-

fect in the horizontal output was to blame.

In this new setup the control-grid bias for the vertical output is supposed to be minus-six volts, drawn through a resistance leg from the minus-30 volts that is on the horizontal-output tube's control grid.

Now, if the horizontal-output tube becomes weak or gassy, this minus-30 drops, lowering the vertical's minus-six in proportion. This makes the vertical-output tube run hotter and hotter, distorting the sawtooth, and causing a vertical foldover. This set's horizontal-output tube had become gassy. A new tube fixed the vertical sweep. I turned on the set and all the stubby-legged performers sporting pointed heads had disappeared.

As I was making out my bill the proprietor of the beauty shop came over. "I'm a barber, too," he said. "How about taking the bill out in haircuts?"

Since I needed a trim, I sat down in a chair alongside a row of women with hair dryers over their heads. No sooner had the scissors started snipping than Hank walked in with my order. That was when he gave his first wolf whistle. **END**

6 Tips for Small-Boat Skippers

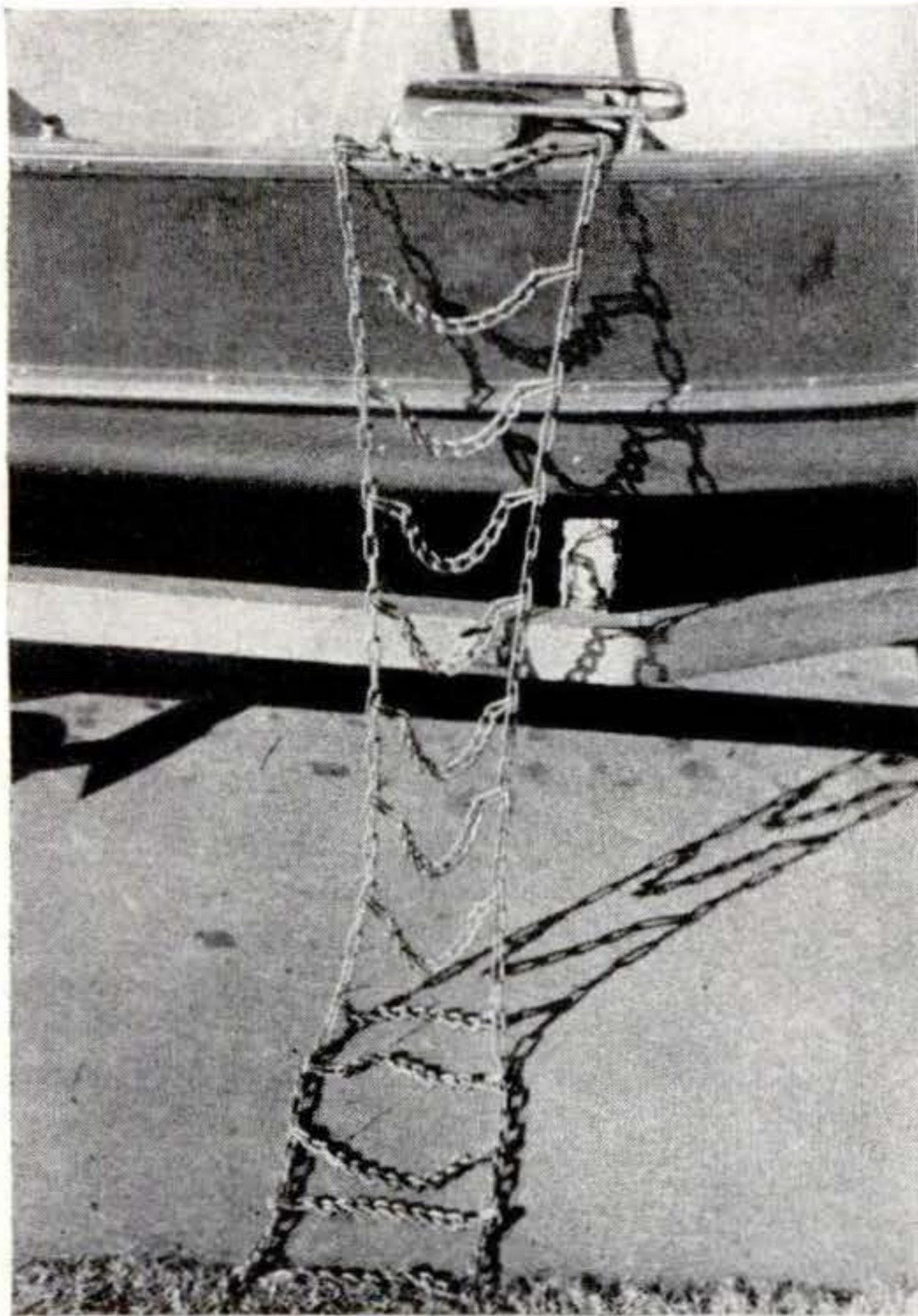

1 Boarding a boat from the water is easy on a ladder made from a tire chain. The end connecting links can be bent into hooks to fit over the gunwale. If desired, garden hose can be fitted on the cross links to protect a swimmer's feet.

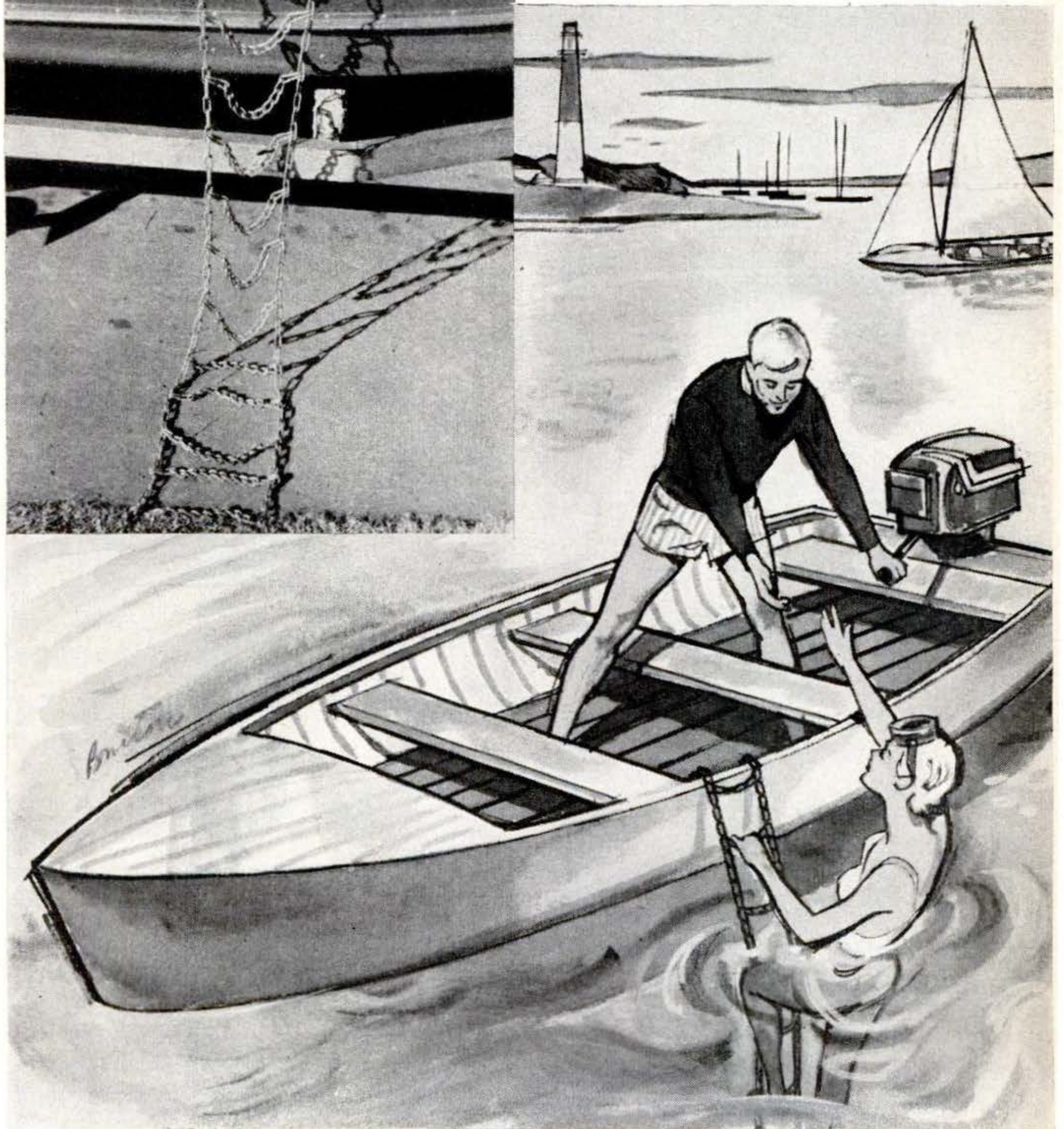

Please turn the page for more boating tips

JULY 1958 177

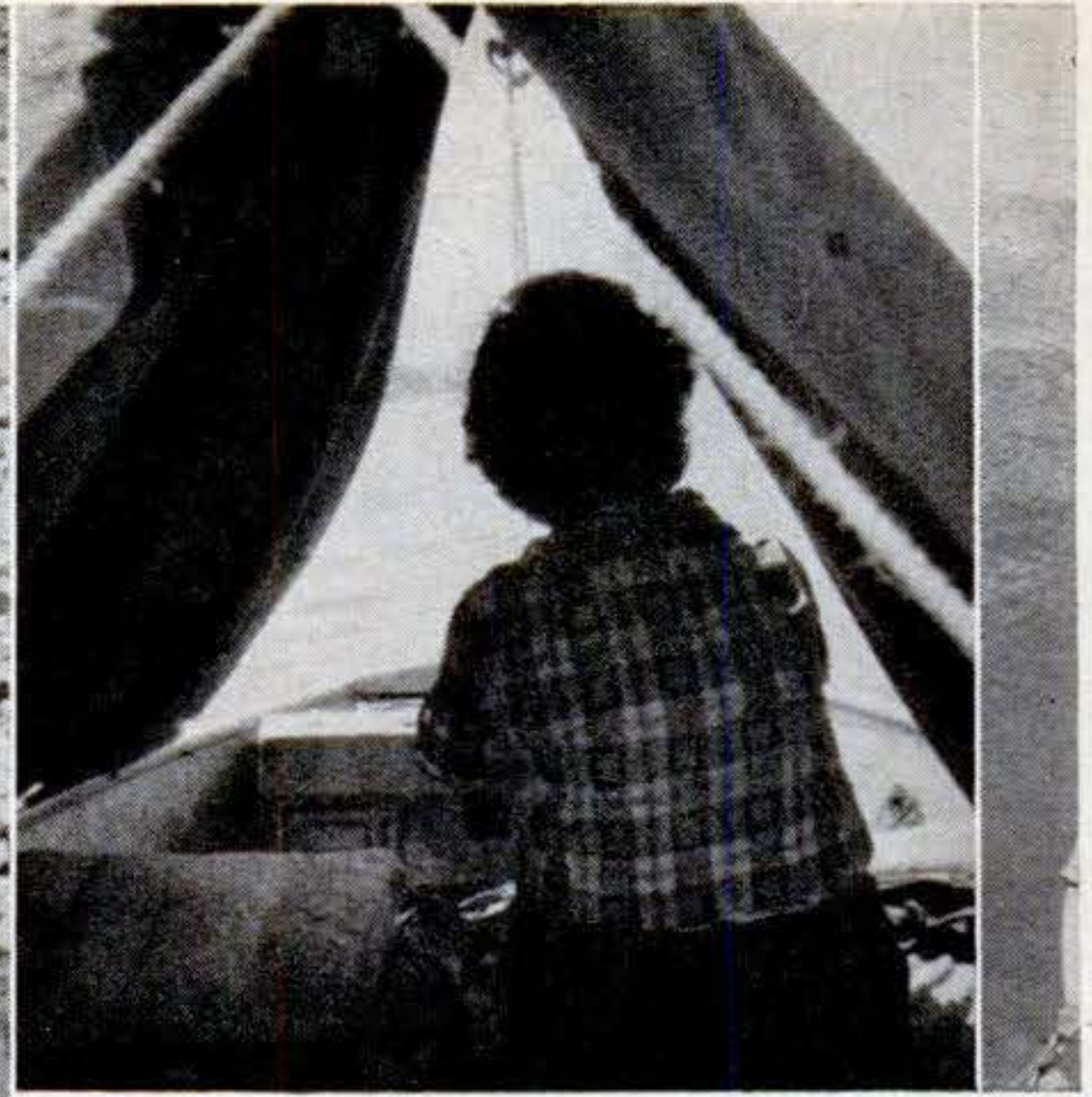

2 A pup tent makes a cabin cruiser out of the 15-foot runabout shown here. Erected over the forward half of the boat, it provides shelter for two sleeping bags spread out on slats that span the seats.

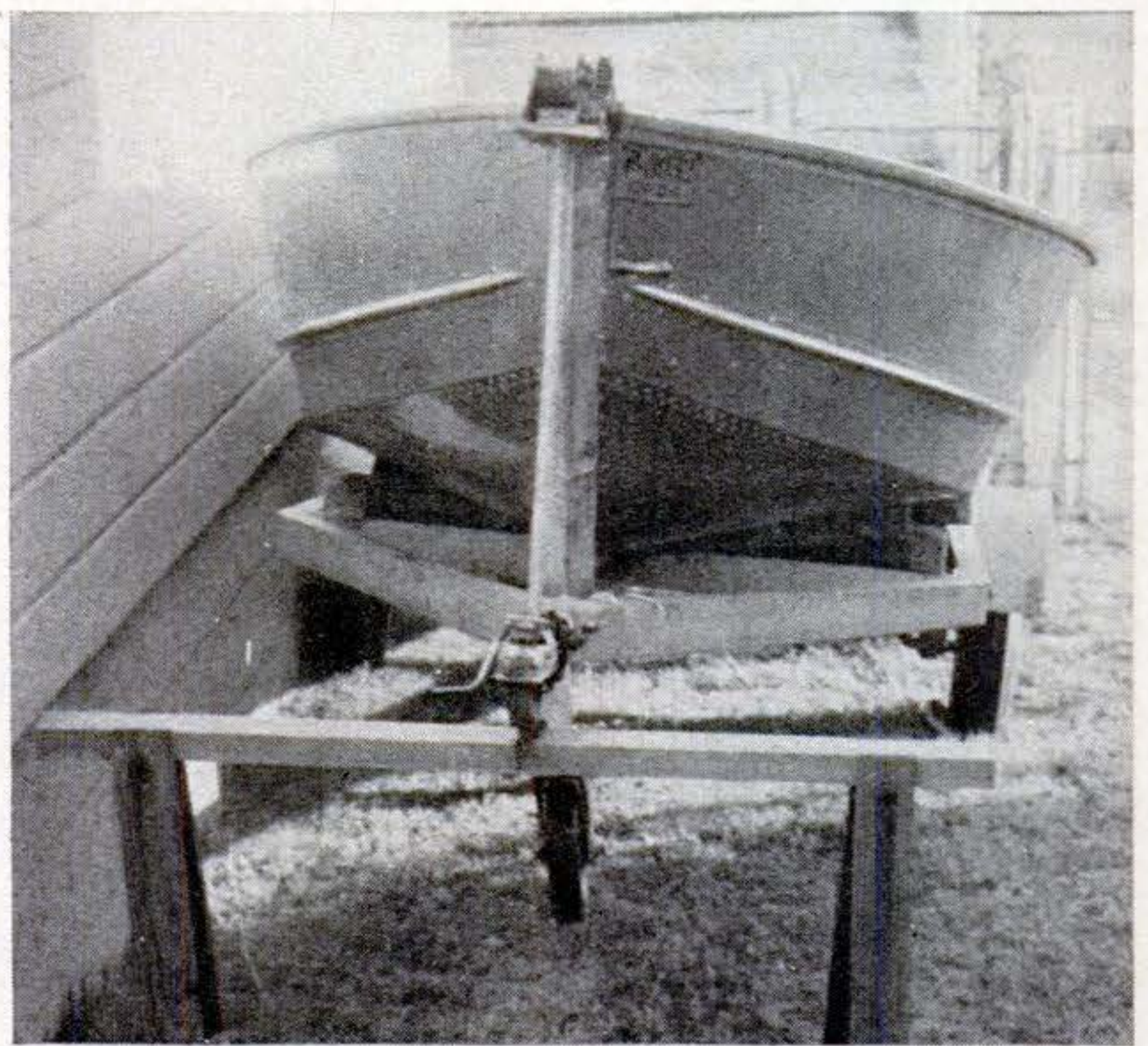
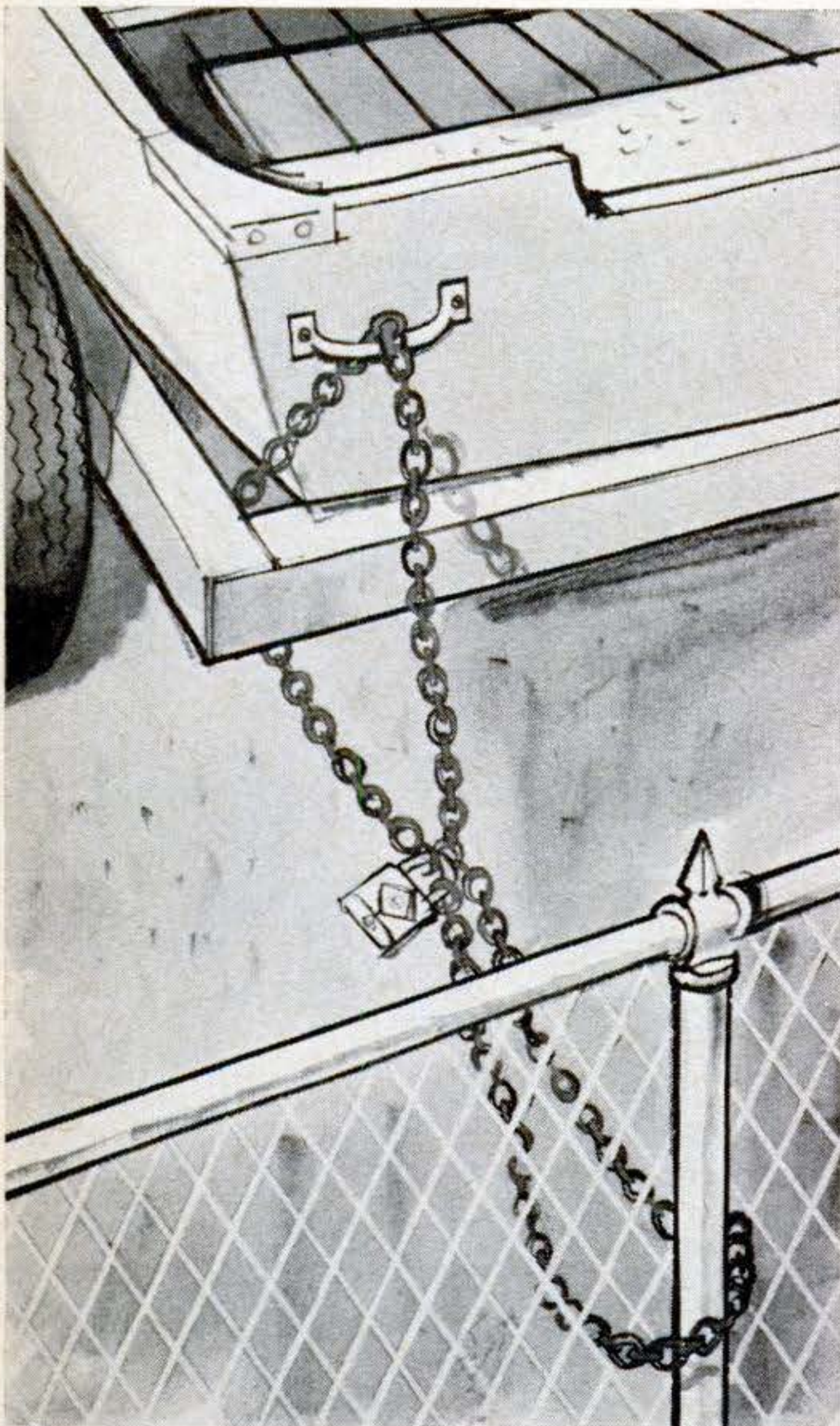

3 Drain rainwater from your boat as quickly as it falls, by propping up the front of the trailer on a sawhorse. Remove the drain plug to let water run out.

4 Use the safety chain on your trailer to protect it when you park. Run the chain through the trailer frame and around a tree or post, then padlock it.

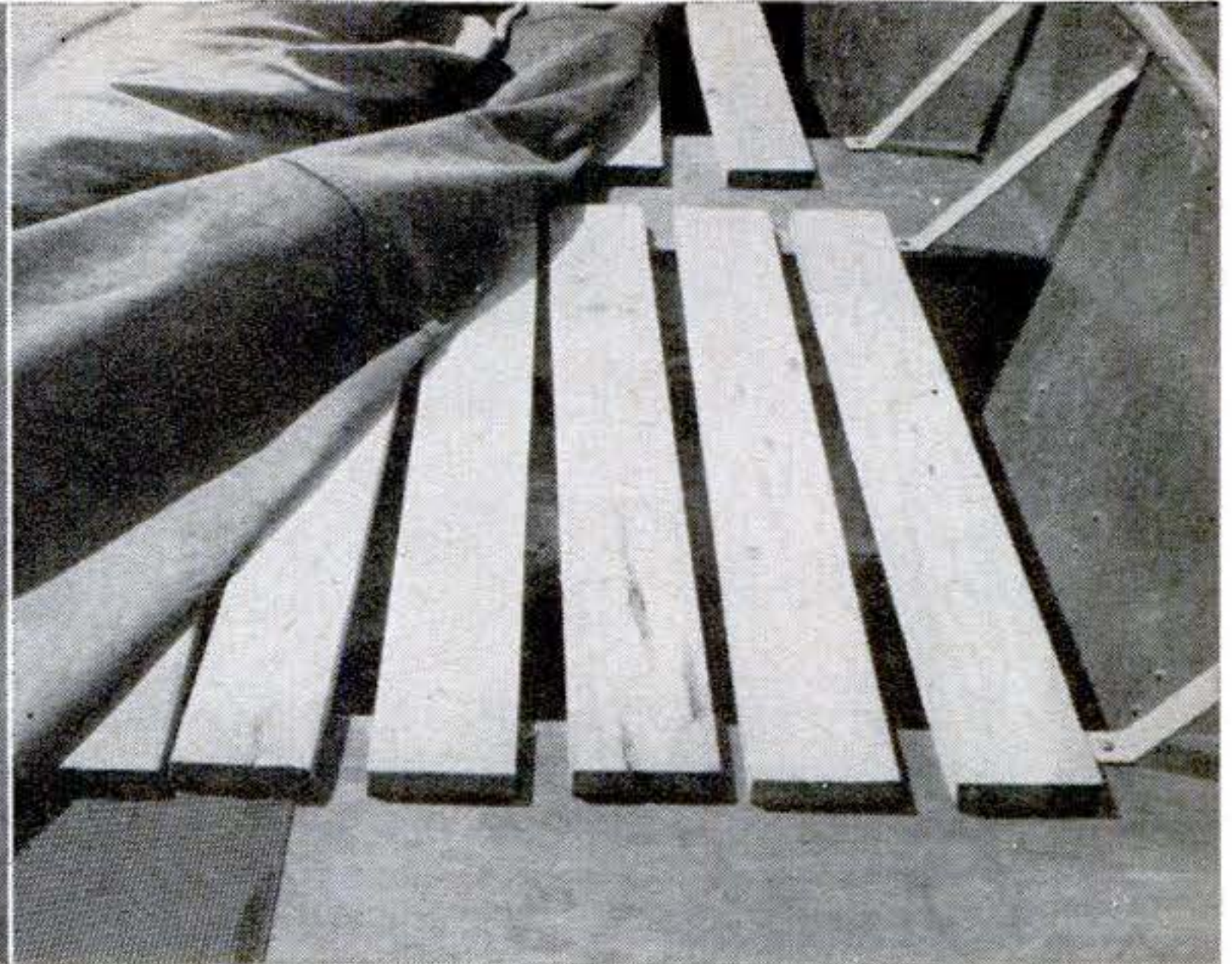

With the tent partly folded back, one person can relax inside, while another fishes from the open stern section. Air mattresses under the sleeping bags and life-preserver cushions make comfortable bedding. Instead of using the tent's center poles, two sets of "rafters" were used to support it. They were made by hinging

paired lengths of furring strips together and notching their ends to fit on the gunwales. Guy lines to the bow and stern keep the tent upright, and suction cups stuck on the outside of the hull provide tiedowns for the tent sides. The slats spanning the seats to make the berth support were cut from one-by-four pine.

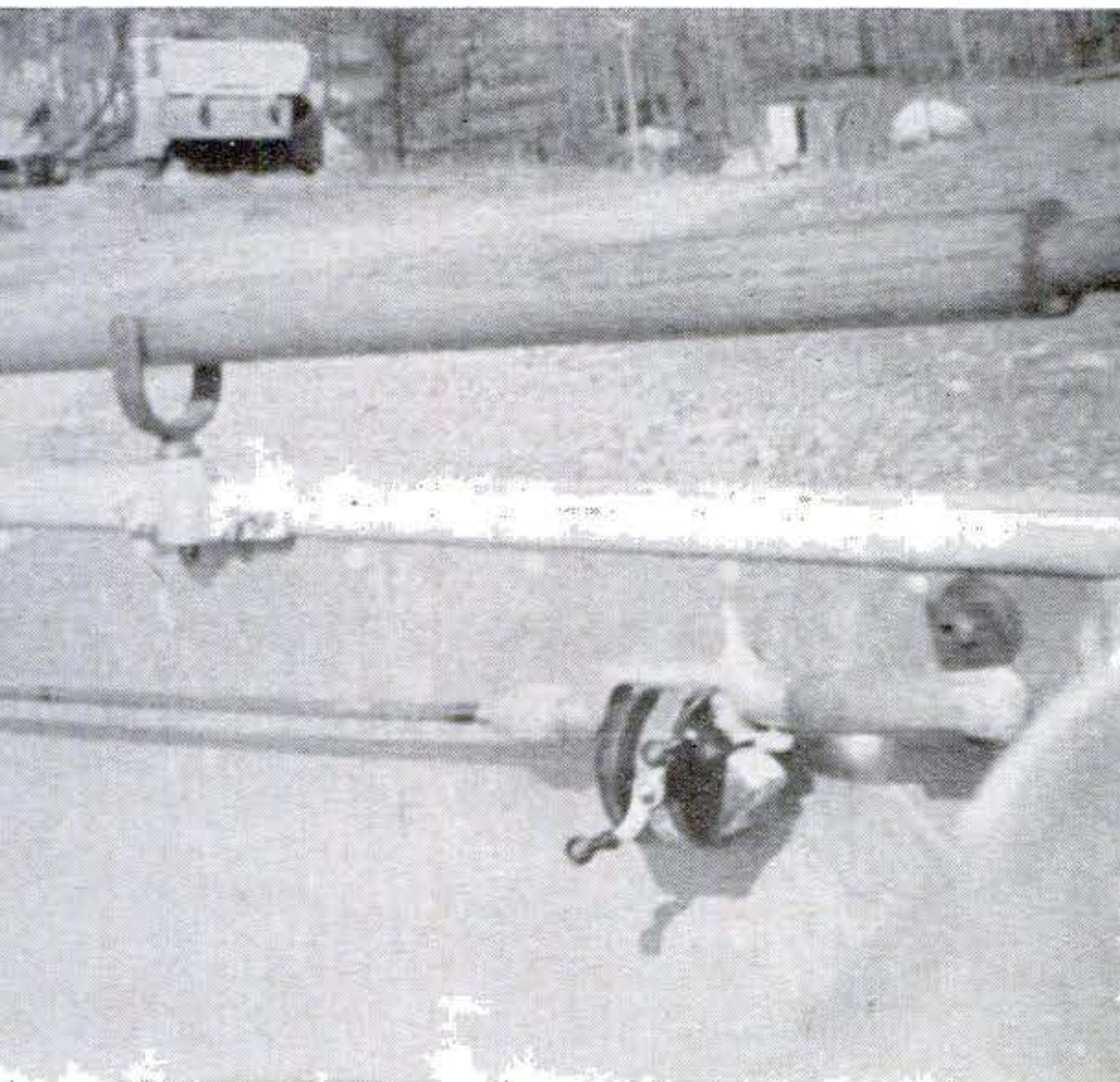

5 Tired of tripping over fishing gear on the bottom of your boat? Make rod holders that stick to the inside of the hull. Buy suction-cup coat hangers (auto-supply stores usually have them), remove the hangers and bolt metal strips to the screws molded into the rubber cups. Then bend the strips into hooks to support the rods. Moistened slightly, the cups stick without marring the finish of the boat.

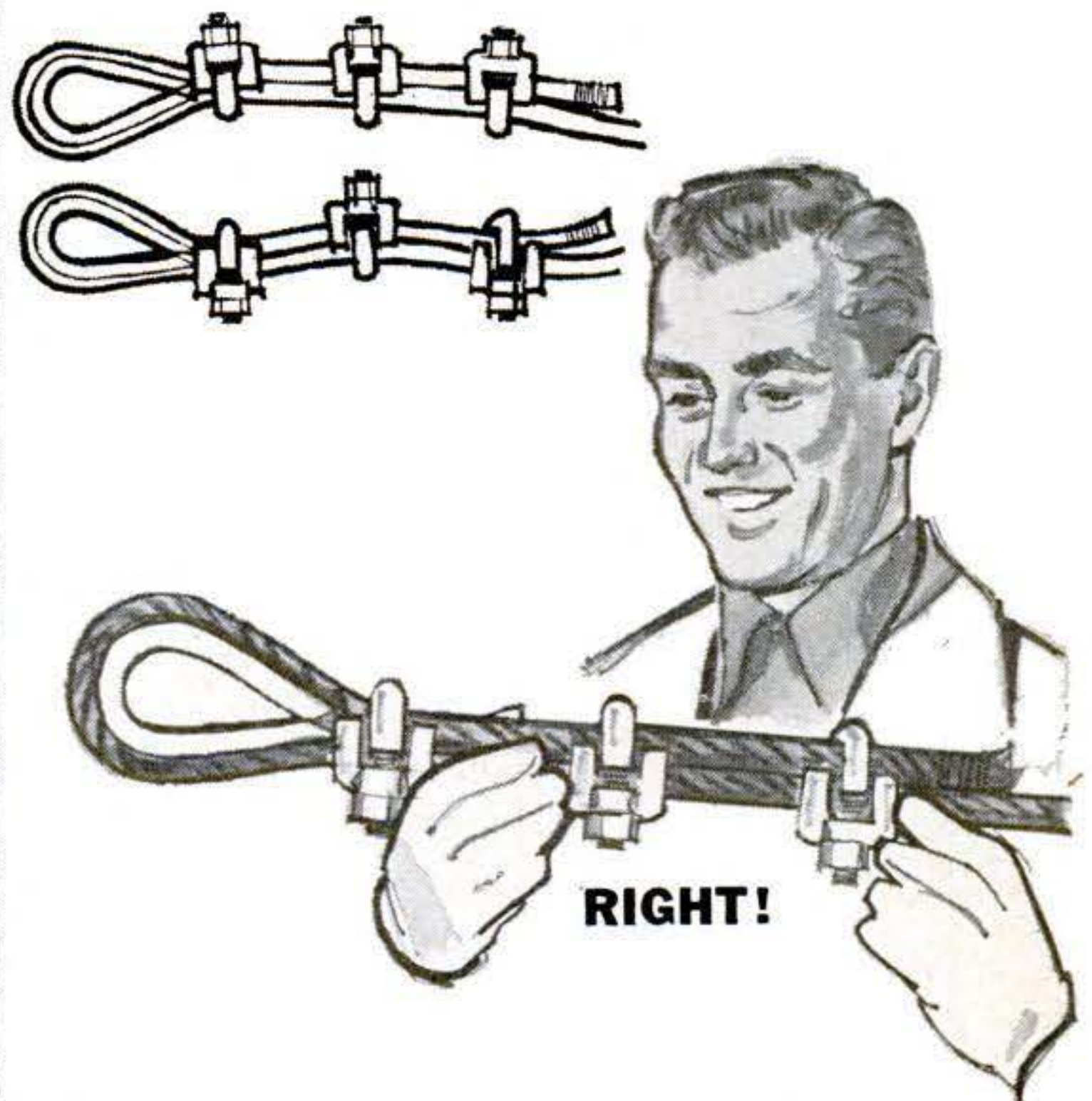

6 When clamping a thimble in the end of a trailer's winch line to form an eye, be sure to place the U section of each clip over the "laying" end—the short, free end—of the wire rope. This protects the "standing" part of the wire, which takes the strain when weight is applied. If clips are placed in either of the two *wrong* ways illustrated, there is danger of crushing and weakening the winch line.

Wordless Workshop

By Roy Doty
and Ruth Westphal

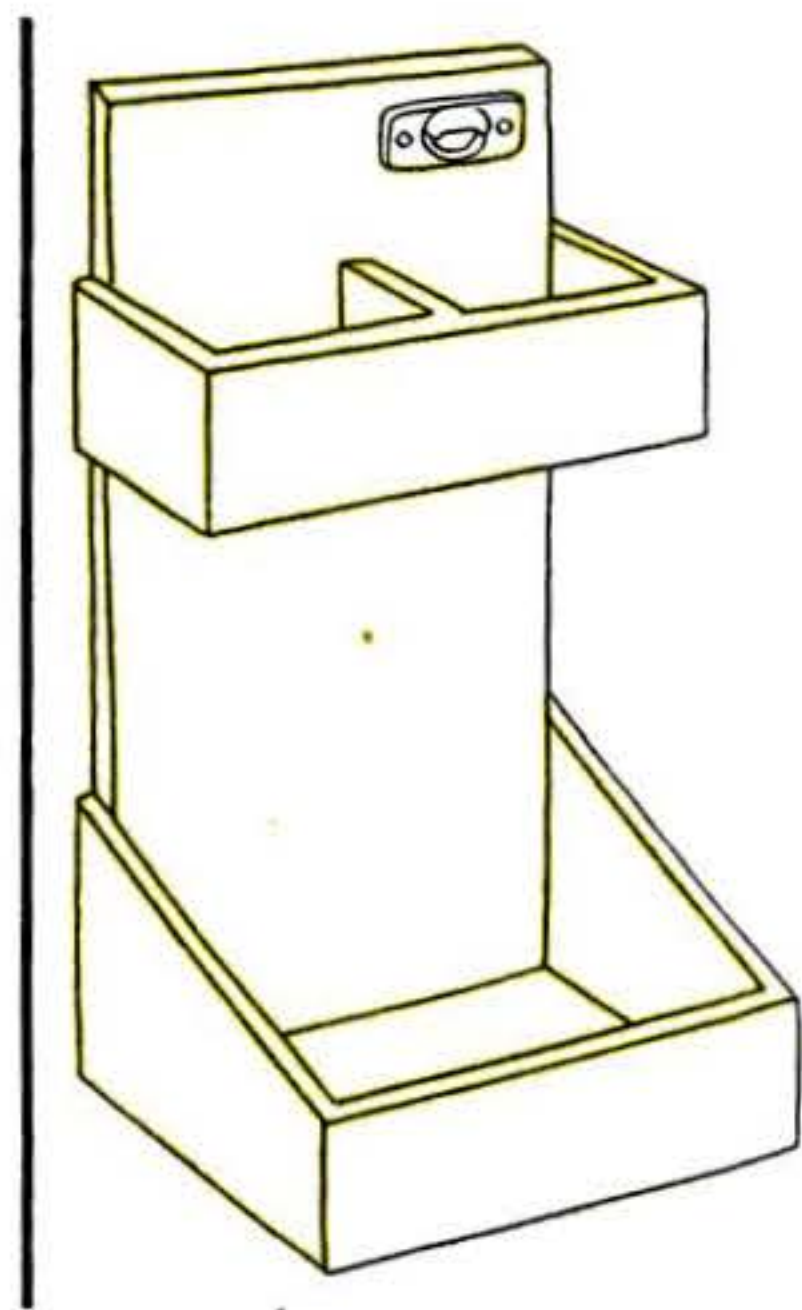
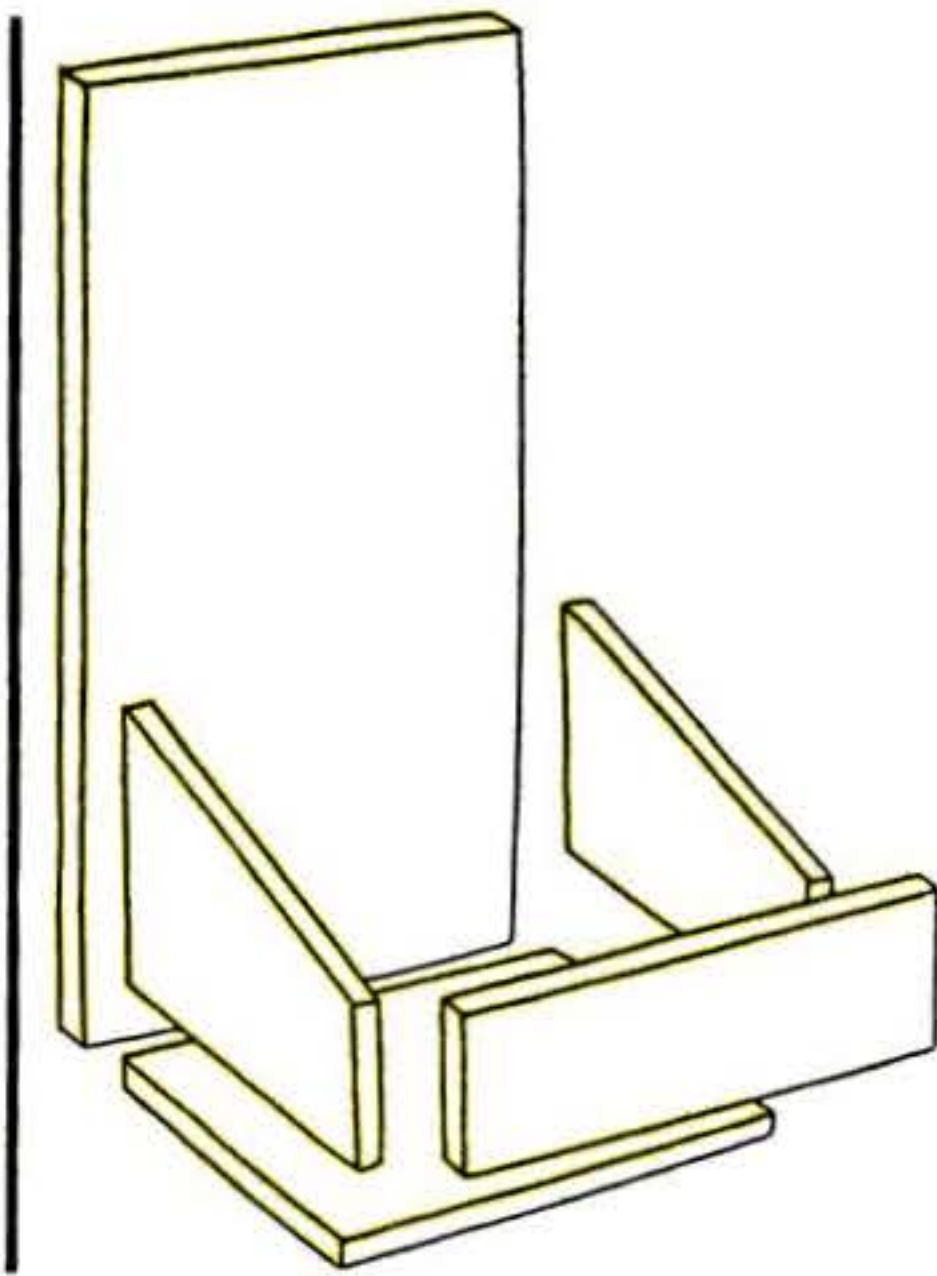
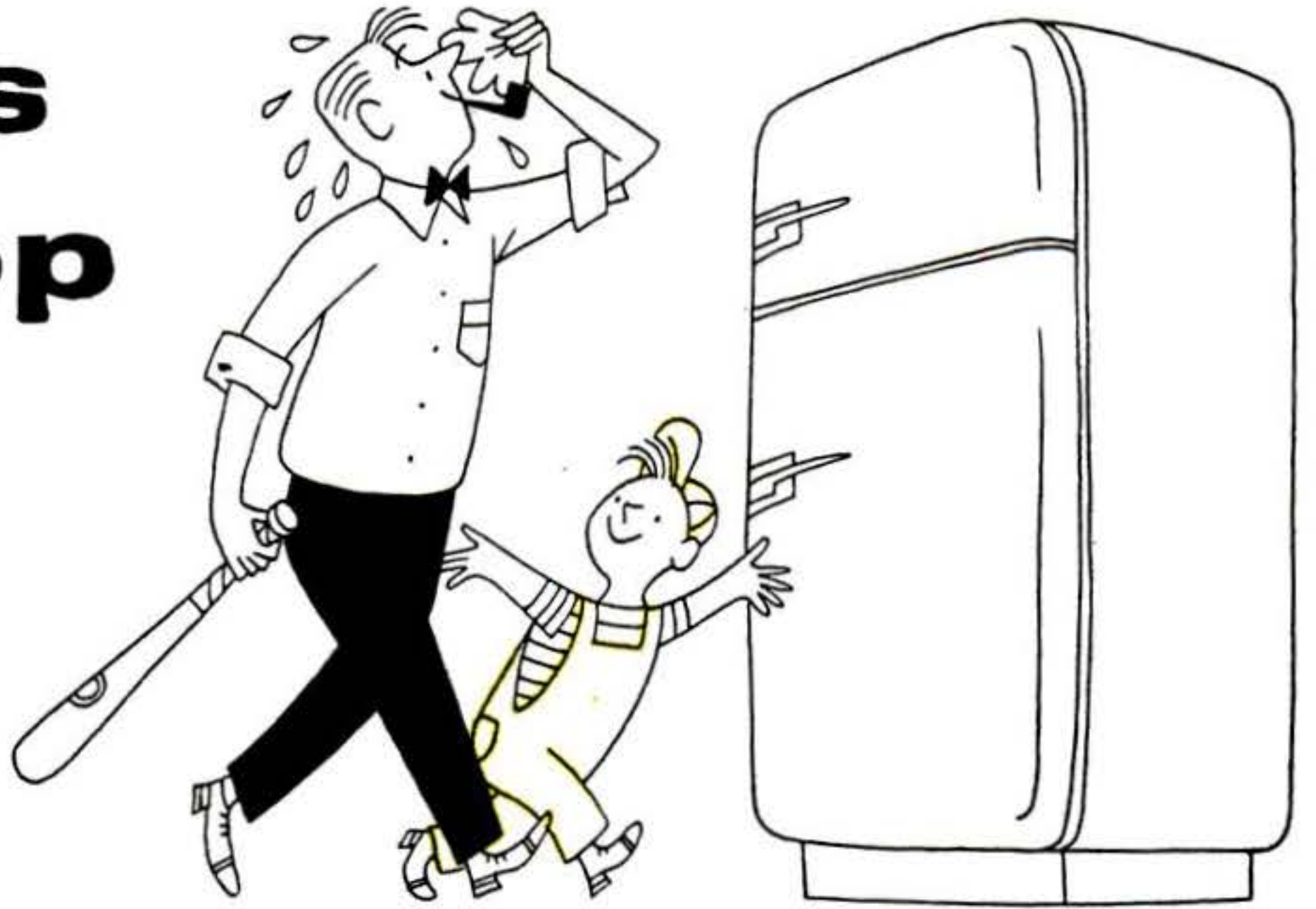

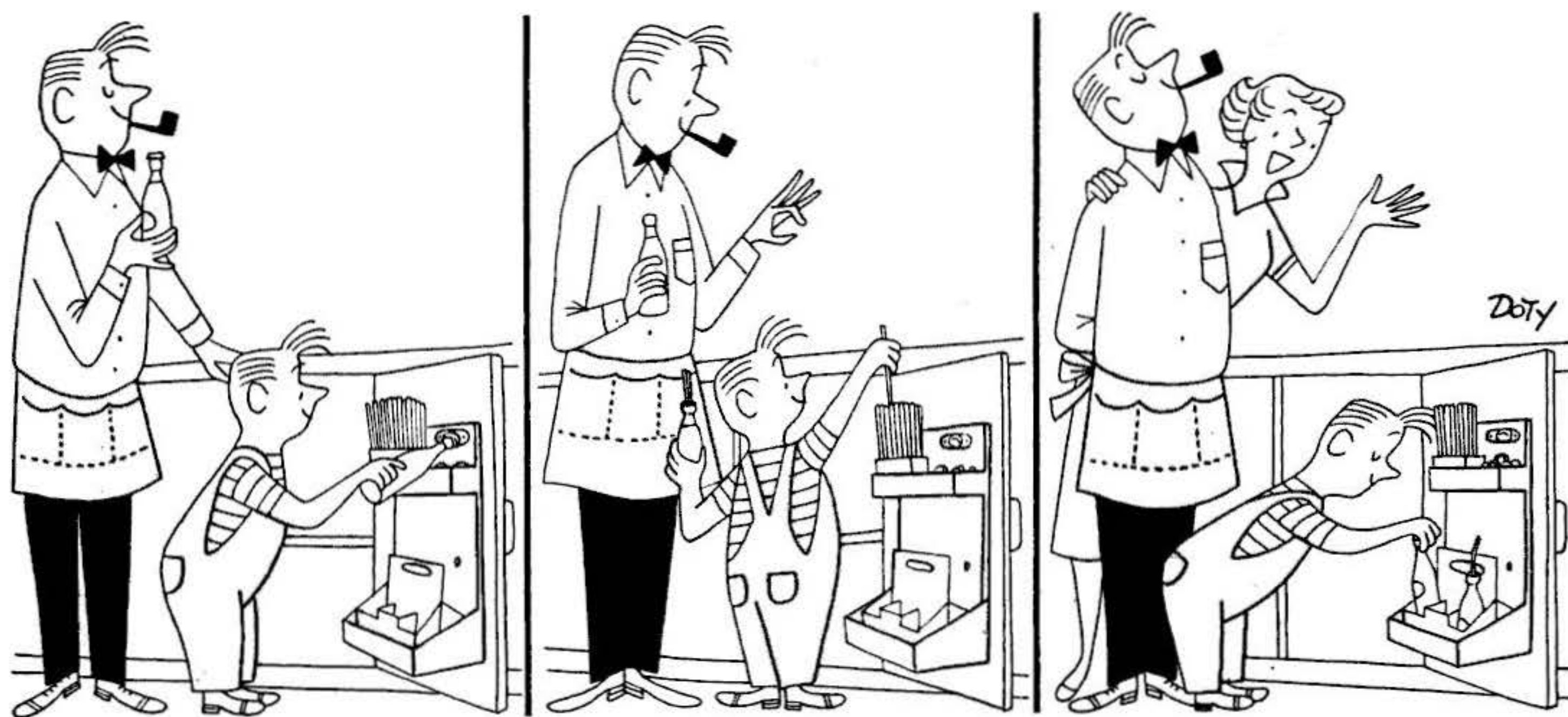

Next Month: A back-yard telephone shelf to save dashing indoors JULY 1958 181



New Hook-Jaw Hex Wrench Hangs On Tight

YOU'LL soon see a brand-new kind of tool in hardware stores—an adjustable wrench designed especially to grapple with the problem of hex-shaped nuts on fancy fixtures like faucets or in hard-to-reach places. It won't chew up a fine chrome-plated finish. It won't bruise your knuckles by suddenly slipping off. You can use it for years on the same soft-metal fittings without rounding off the corners.

The new wrench, just announced this month, will handle all types of fittings, but its real meat is the hex. Its hook-shaped jaw literally wraps itself around the nut. Its grip is tenacious, yet gentle. As you pull on the wrench, the jaws

tighten on the nut, instead of remaining fixed. This keeps the jaws from rocking on the corners of the nut and wearing them down.

Because of the self-tightening action, you can set the wrench to slip on and off the nut easily without fear of a slippery fit. Any slight looseness is taken up by the squeezing action of the jaws. The jaw is not spring-mounted, so that, if necessary, you can rotate the wrench backward without its opening.

Three sizes of the new wrench will be sold by the Ridge Tool Co., Elyria, Ohio, for about \$3 to \$9. The smallest size will take nuts from $\frac{3}{8}$ " to $\frac{3}{4}$ "; the largest, 1" to 2" nuts.

EVEN TRICKY JOBS ARE EASY—like tightening the chrome-plated faucet bonnet below, at left—because nuts are locked tightly in wrench's "crook." Jaws are so smooth and snug that no

pads are needed to avoid scratches. Photos at center and right show how different-size nuts automatically center themselves so the wrench can be slipped on and off quickly.

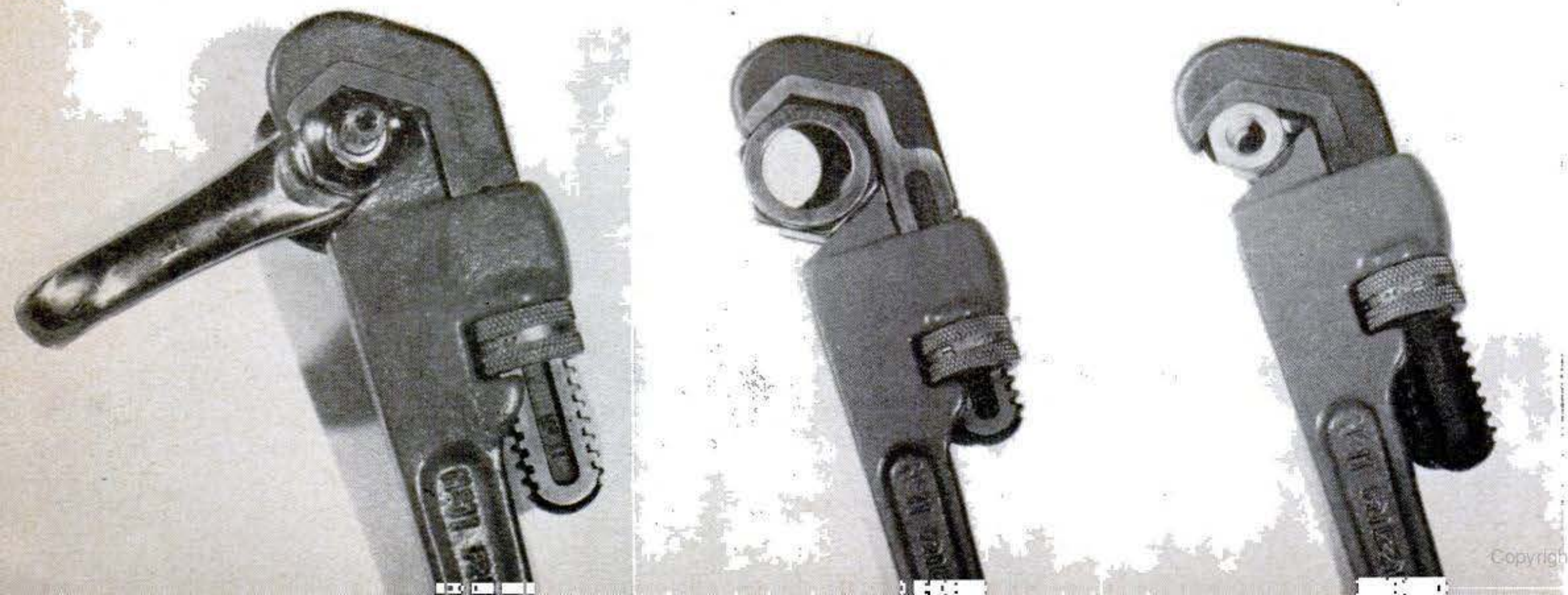

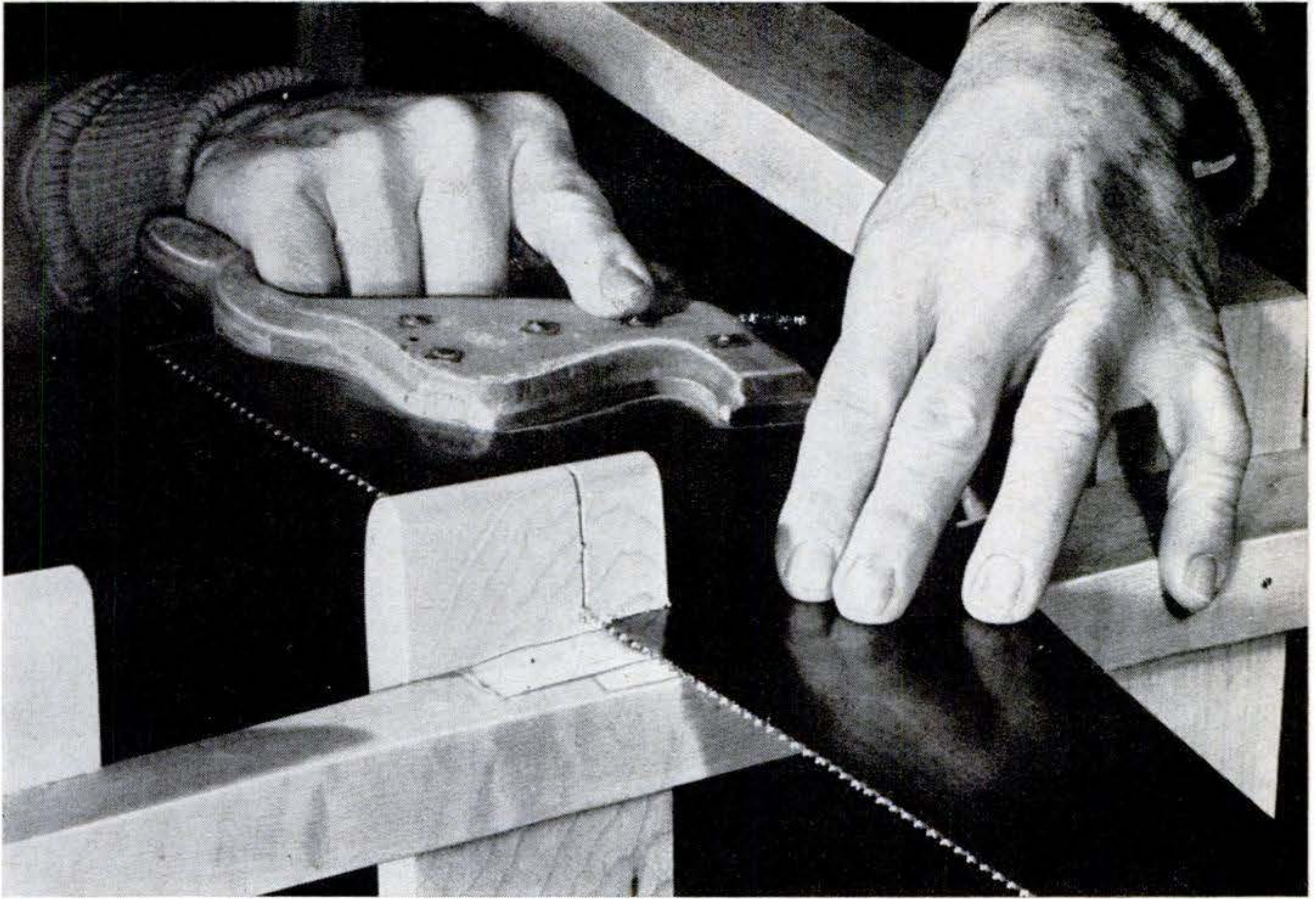

Masking Tape Guards Against Saw Scratches

WHEN you have to graze the surface of one piece while sawing another at right angles to it, you can keep from scratching the grazed member by protecting it with two layers of masking tape. —*Edwin M. Love, Palmdale, Cal.*

Short Cuts and Tips

FROM PS READERS

Utility Palette Is Made from Blown Fuses

DISCARDED glass household fuses can be converted easily into a neat holder for water colors, glue, flux or solvents.

You simply bend up the small strip soldered at the top of the brass base and unscrew the base. Everything drops out, leaving a clean little glass container.

Several can be set in blind holes drilled in a strip of one-by-two stock and fastened under the edge of the workbench or a drawing board. If you install it with a single pivot screw, you can swing it out of the way under the surface when it is not being used. —*Bil Toman, Palatine, Ill.*

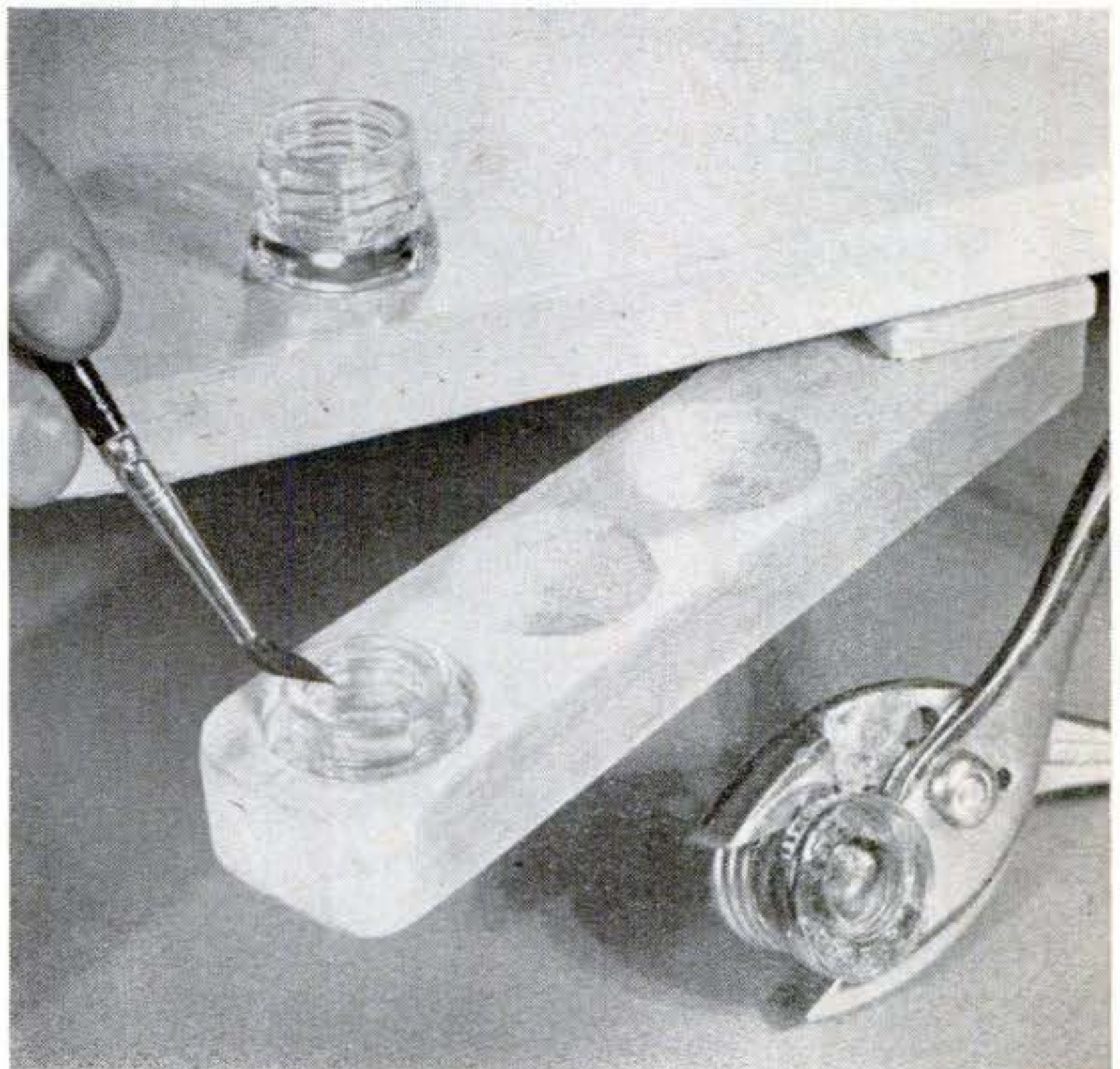

Short Cuts and Tips

.....

Hang-Up Tops for Small Tubes

You can seal tubes of cement, glue or wood putty by screwing a cup hook or screw eye into the opening.

This not only seals the tube as effectively as the old stopper but makes it possible to hang it from a wire or another cup hook.—

Bill Caine, Red Bluff, Cal.



Continuous Temperature Gauge

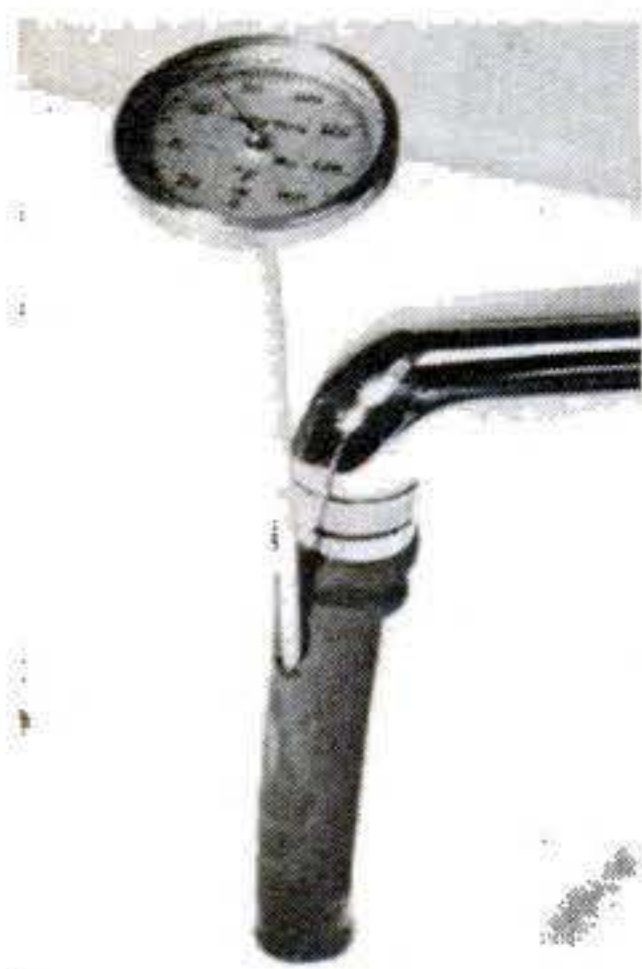

WITH this rig you can keep a constant check on water temperature while processing photo film.

First attach a short length of hose to the faucet, and then make a small hole in one side of it to hold a thermometer of the rod type.—*James Edwards, NYC.*

Modelmaker's Needle Drill

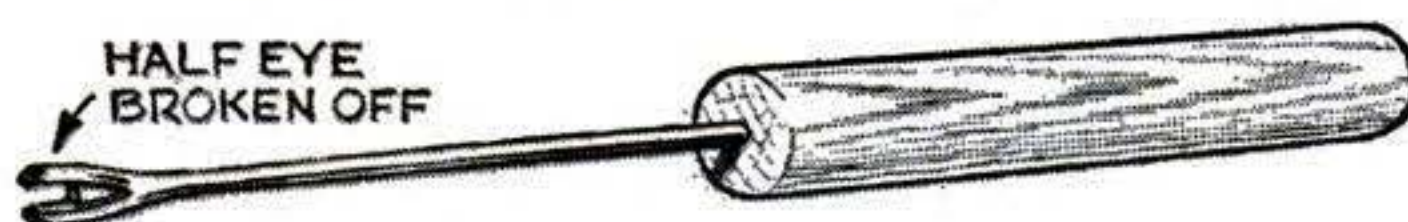

WHILE building a ship model I had to make some tiny holes, but lacked small enough drills. So I cut a 1" length of $\frac{1}{4}$ "-diameter dowel and shoved a large sewing needle about $\frac{1}{2}$ " into the center of one end. Then I broke off half of the needle's eye, making it a two-prong drill.

Rotating the dowel drill holder by hand with a very light touch produces good results.—*Edmund K. Walters, Chicago.*

.....

Home-and-Shop Index Is Yours for the Asking

DO YOU keep a file of back issues of POPULAR SCIENCE? Would you like to make sure that you'll always be able to put your finger on home, shop and handicraft articles of special interest?

An index to help you is now ready. It covers the issues from July, 1957, through June, 1958, and is free to readers who request it, as long as the supply holds out. Just send your name and address on a card or in a letter, saying you want it. This index, and one for July, 1956, through June, 1957, are the only ones available. Address your request to: Index Editor, POPULAR SCIENCE, 353 Fourth Ave., New York 10, N. Y.

.....

Short Cuts and Tips

.....

Heating Asphalt Tile with a Grill

NEXT time you have asphalt tile to lay, get out your charcoal broiler and keep it handy. With a small fire going and a heavy-gauge metal sheet over the grill, you can quickly heat tiles to be bent or cut.

The tile will be heated evenly and you can do several at a time if you like.—*C. Cerkliski, Norridge, Ill.*

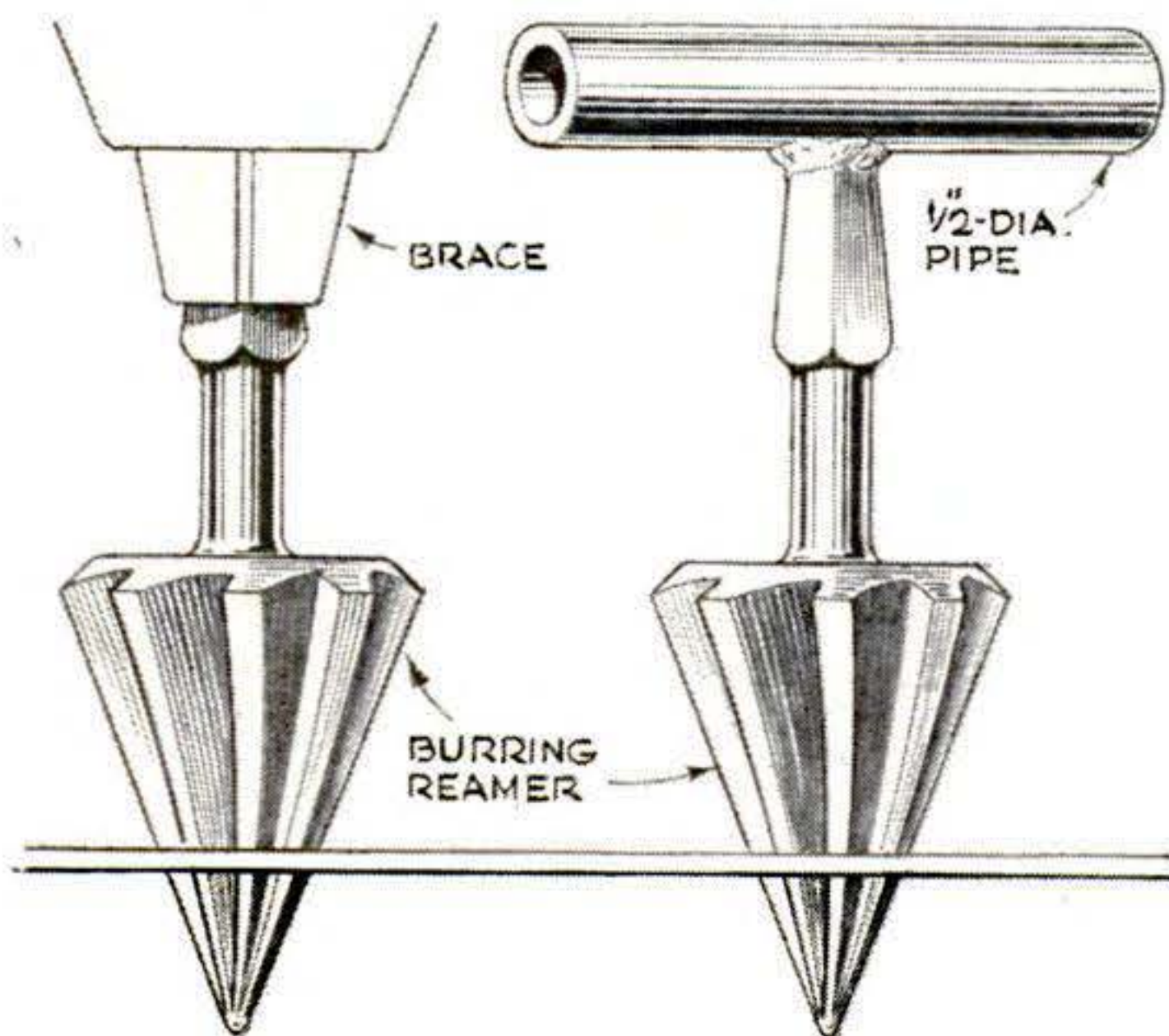
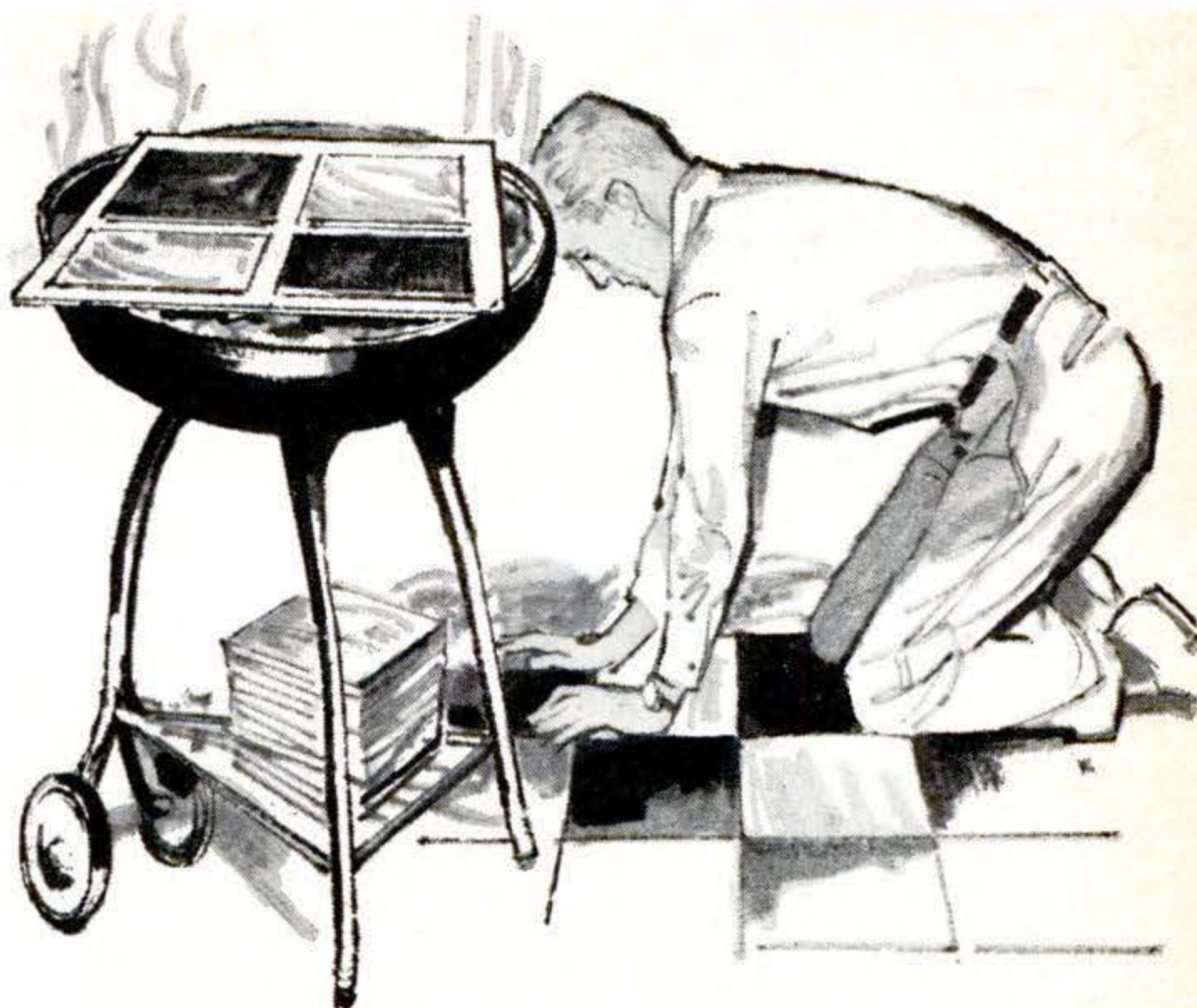

Reamer for Sheet Metal

A PLUMBER'S burring reamer does a fast job of enlarging holes in sheet metal. I've used one to install a cigarette lighter and a heater switch in the dashboard of a car and a truck.

The reamer is made to be chucked in a brace and bit, but for strictly hand use you can braze a short length of 1/2"-diameter pipe on the top of the shank as a handle.—*Mike Parsons, Salt Lake City.*

▶▶▶THE paints and enamels that come in pressurized cans spray best if their temperature is above 70 degrees. On cool days, dip the container in a pan of lukewarm water. But keep it away from open flame.—*Ben Todd, Peru, Ill.*



Pipe Nipple Is Tool Holder

CAP both ends of a suitable pipe nipple and you will have a strong case to keep stiff wire probes, small files and the like separate from other tools in the box or bench.—*Farley Jones, Jersey City, N. J.*

FROM KODAK—photo aids to

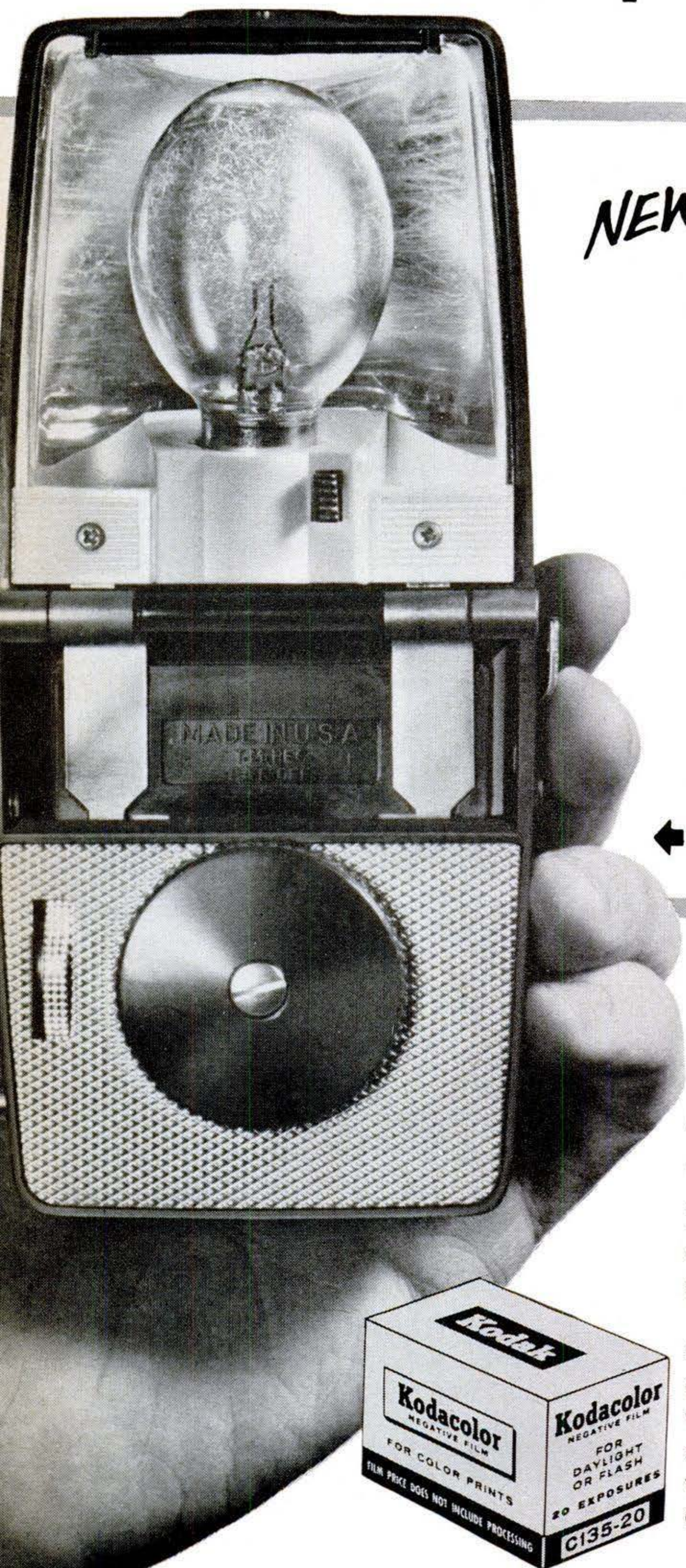

NEW!

Kodak Generator Flashholder makes its own power for flash shots!

Exciting new flash idea—makes its own power! Just twirl the knob—and fire! Folds to palm-size, fits your pocket. Takes all M-2, No. 5, and M-25 flash bulbs. Simplified exposure calculator covers both EVS and f values. Two models to fit most cameras. Kodak Generator Flashholder . . . \$13.95 and \$14.95 or \$1.50 down. (Also available in a battery model, \$7.95.)

← **ACTUAL SIZE** — open for use.

NEW!

A 35mm film made especially for color prints —Kodacolor 135!

New Kodacolor 135 for 35mm cameras. Gives you color *negatives* for color prints and enlargements.

Kodacolor 135 is a fast color film (Daylight Index 32) that can be used indoors or out—without conversion filters. Try new Kodacolor 135 Film this weekend. A 20-exposure roll is only \$1.85.

help you make better pictures!



Kodak Rotary Flashholder lets you take 6 flash shots without reloading! Simply revolve magazine turret for fresh bulb. Eject all spent bulbs simultaneously, reload in seconds. Has simplified exposure calculator. Complete with Midget B-C Flashpack, two carrier discs. Two models, from \$10.95.



Kodak Filters for color pictures and better black-and-white shots. Daylight Filters (No. 85 and 85C) convert indoor Kodachrome Film to outdoor use. Skylight (No. 1A) reduces excess blue in hazy-day color shots. Kodak Pola-Screen Filter darkens sky without changing colors. Many others, from \$2.25.

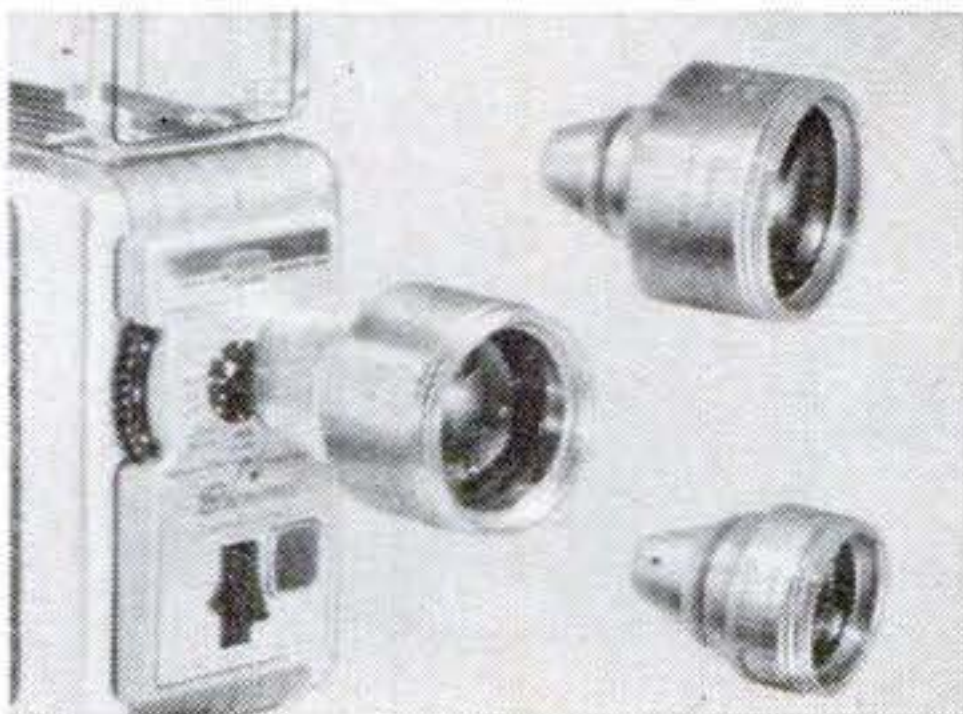

Kodak Lens Converters slip on for wide-angle and telephoto movies with single-lens Brownie and Kodak Medallion Cameras. Each converter, \$18.50.



Kodak Field Cases give your camera the protection it deserves, are designed so camera is instantly usable. Smartly styled cases to fit most Kodak Cameras, from \$2.95.

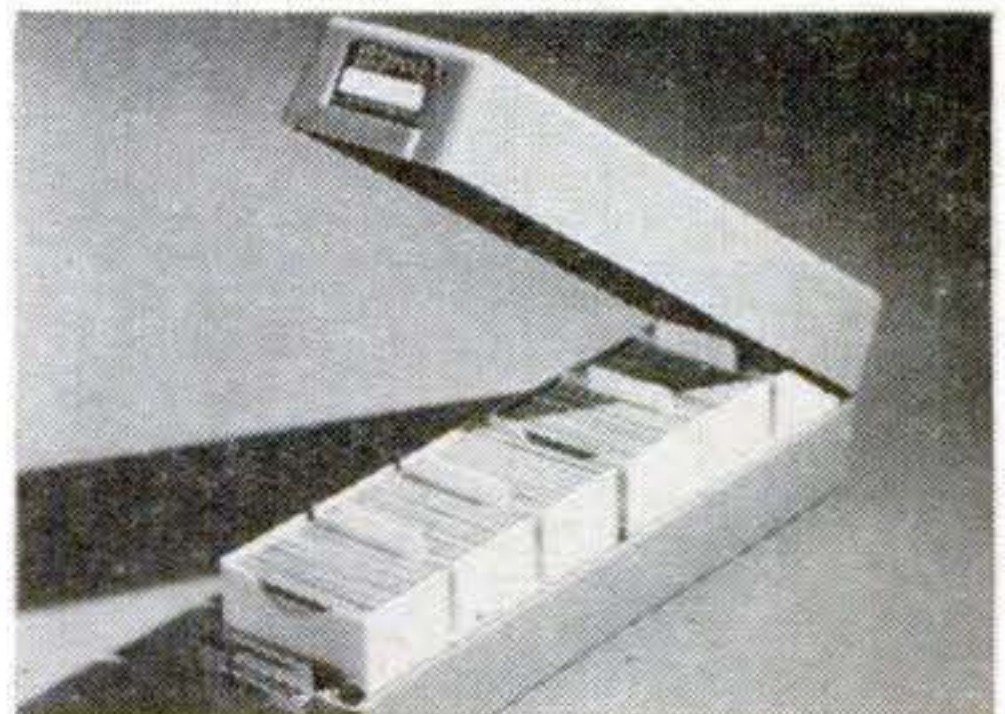

Kodak Slide Files keep your color transparencies safe and in order. Kodaslide Ready-File, above, holds up to 200 cardboard 2 x 2 slides; \$2.25.

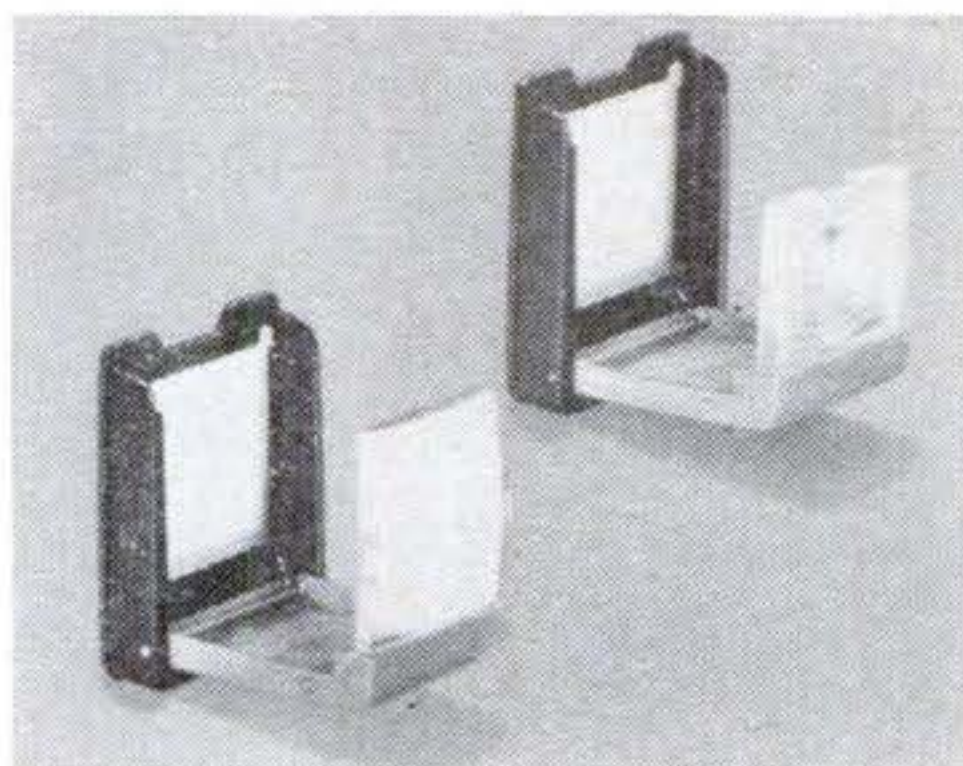

Kodak Pocket Viewers let you view color slides in existing light, give four-times magnification. Model 1, \$2.25; Model 2, permits viewing with both eyes, \$2.50.

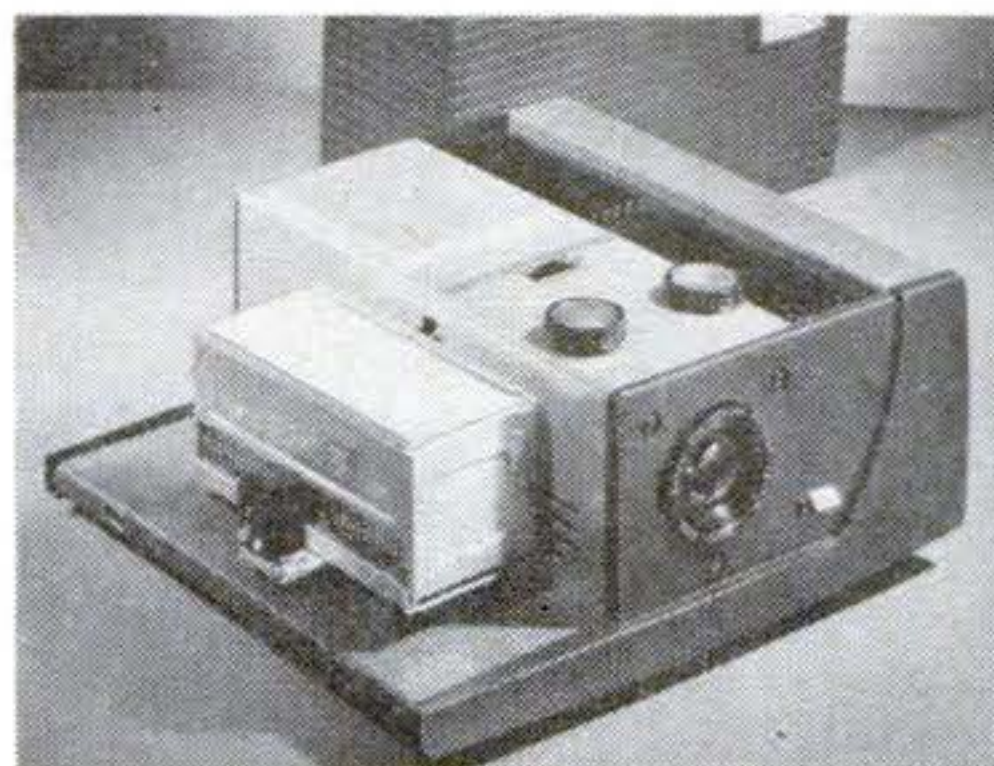

Kodak 500 Projector shows your color slides big and bright, yet weighs only 9 pounds! With magazine changer, \$84.50; with Kodak Readymatic Changer, \$74.50.

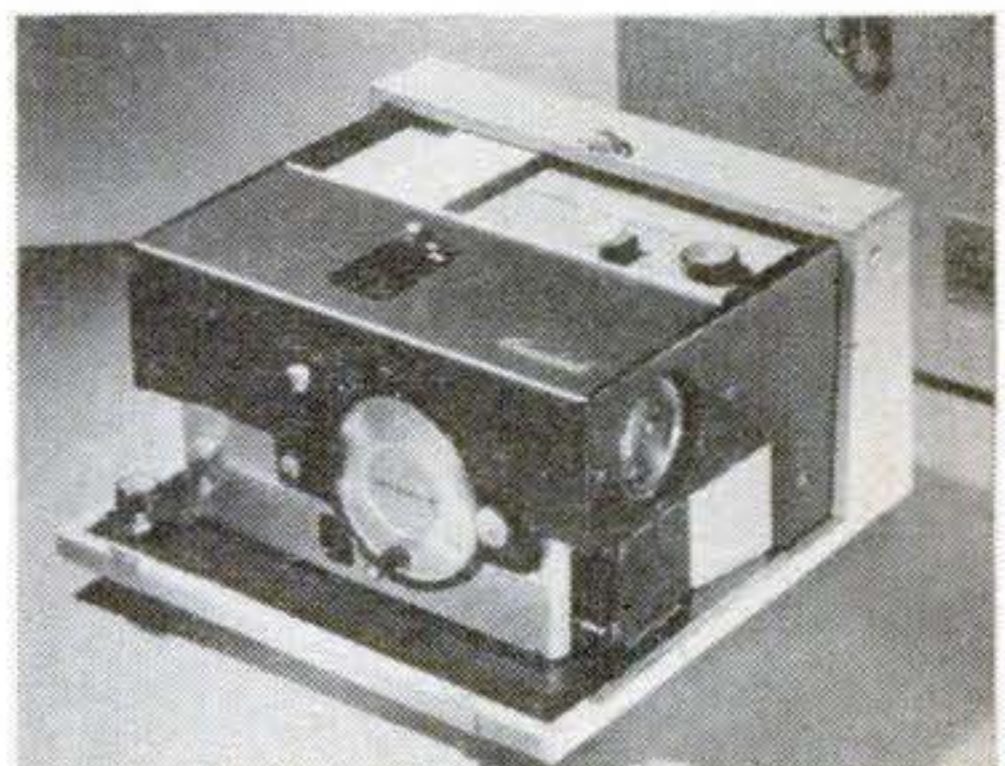

Kodak Cavalcade Projector is *automatic*—changes slides by itself! Keeps in constant focus, many other features. \$149.50 or \$14.95 down.

(Prices are list, include any Federal Tax, are subject to change without notice.)

See Kodak's "The Ed Sullivan Show" and "The Adventures of Ozzie and Harriet"

EASTMAN KODAK COMPANY, Rochester 4, N. Y.

Kodak
TRADE MARK

JULY 1958 187

Short Cuts and Tips

.....

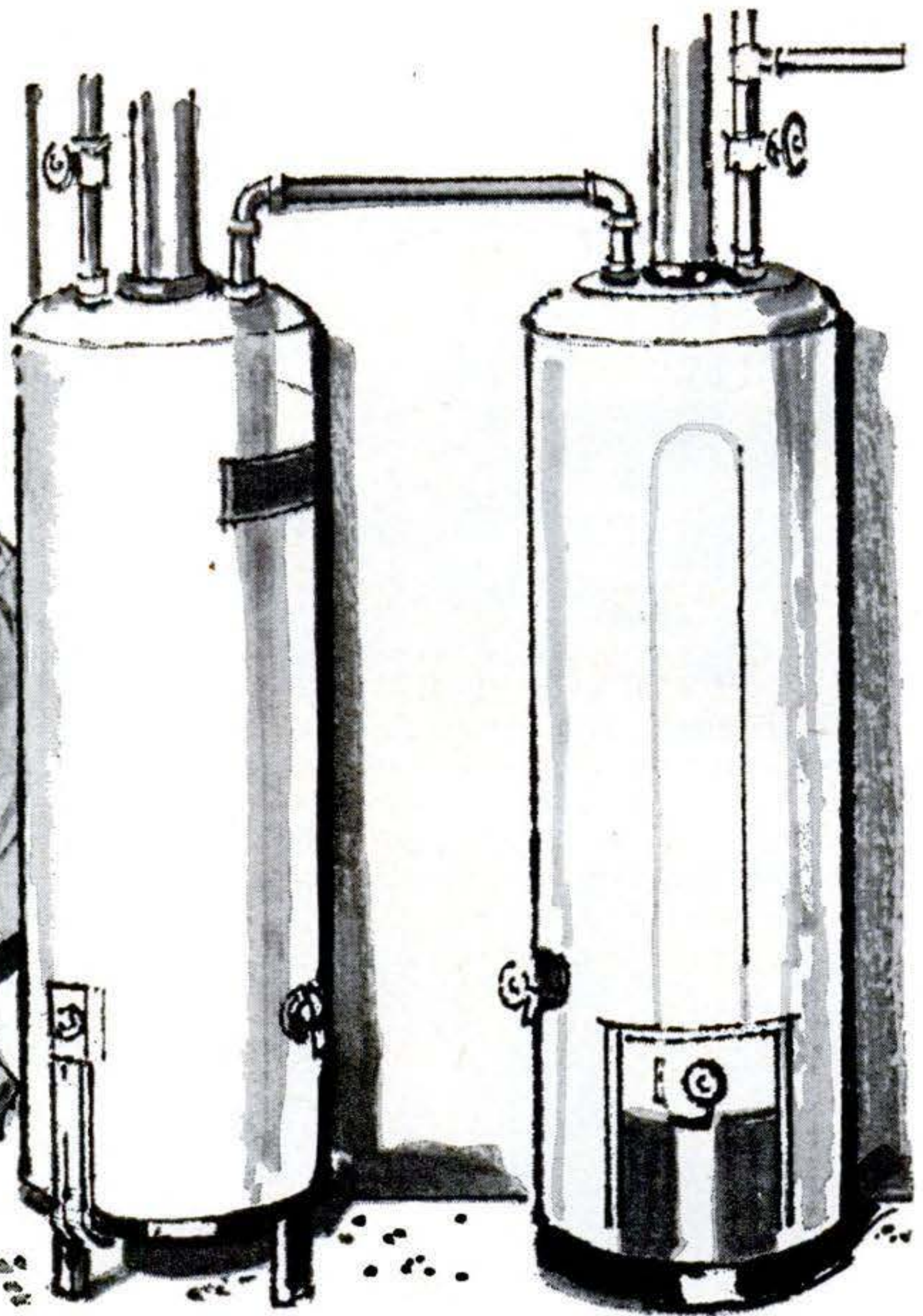
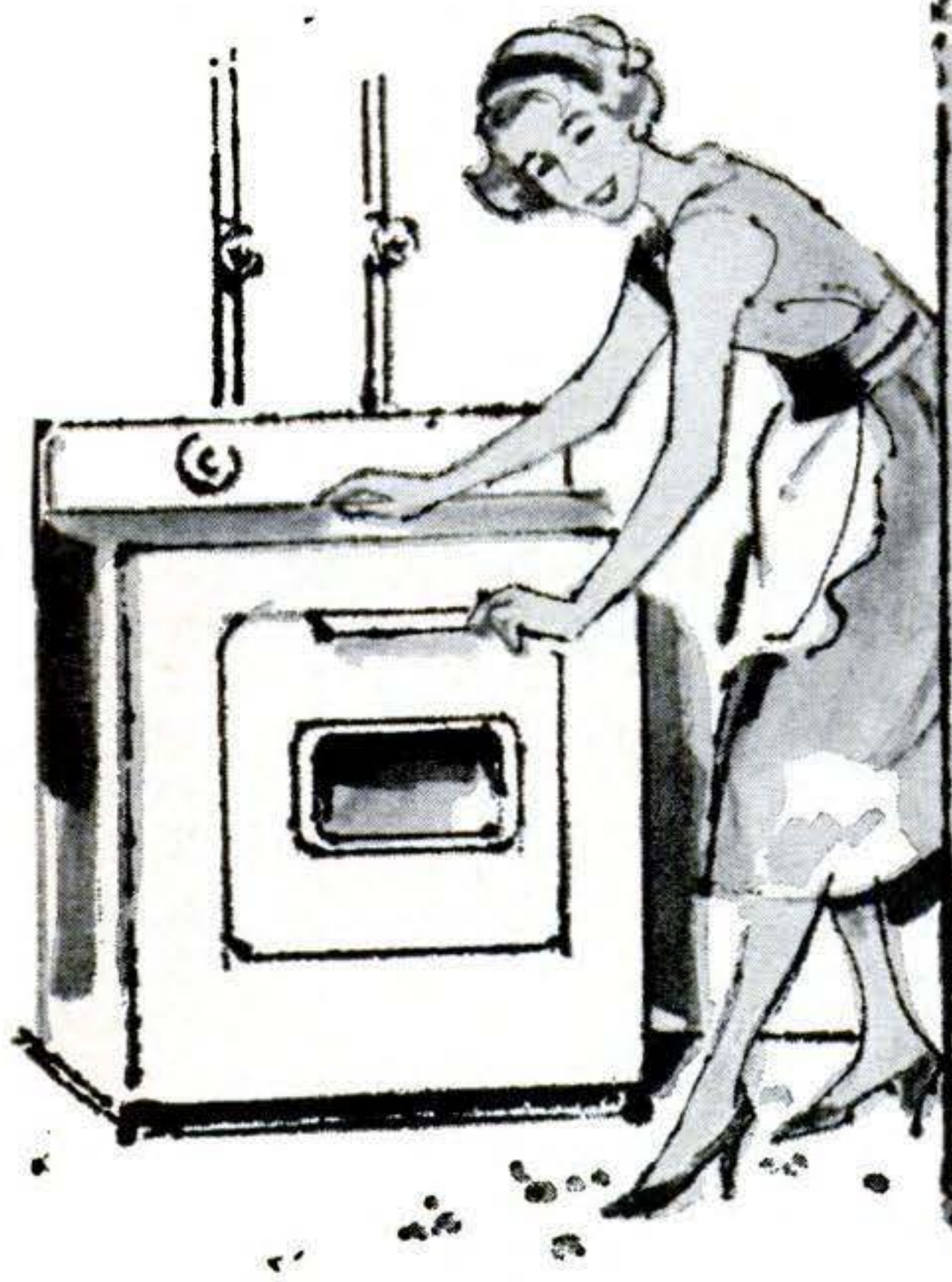

How I Use Two Water Heaters

WHEN I bought an automatic washer for my wife she was delighted—until our 30-gallon water heater took nearly two hours to recover after the first load. So I

installed a second 30-gallon heater ahead of the first, with its thermostat set at about 10 degrees lower.

Now we keep 60 gallons of hot water on tap.—*William Schroeder, Milwaukee.*

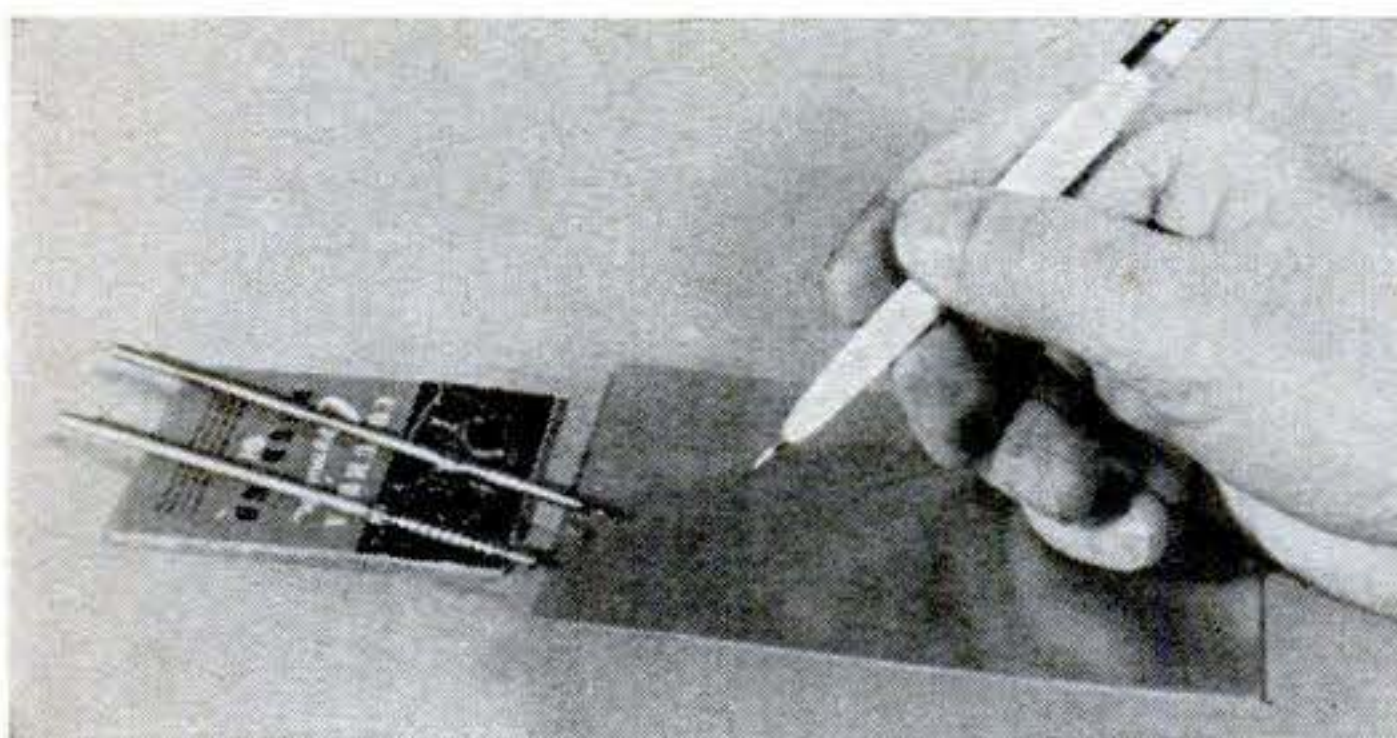

Ball Pen Made into Scriber

A METAL scriber that you can carry in your pocket can be made with a phonograph needle and a ball-point pen. File off the point of an empty ink cartridge and enlarge the opening to accept a long-wearing needle. Retract the tip when it's not in use.—*Keith Morris, Cadillac, Mich.*

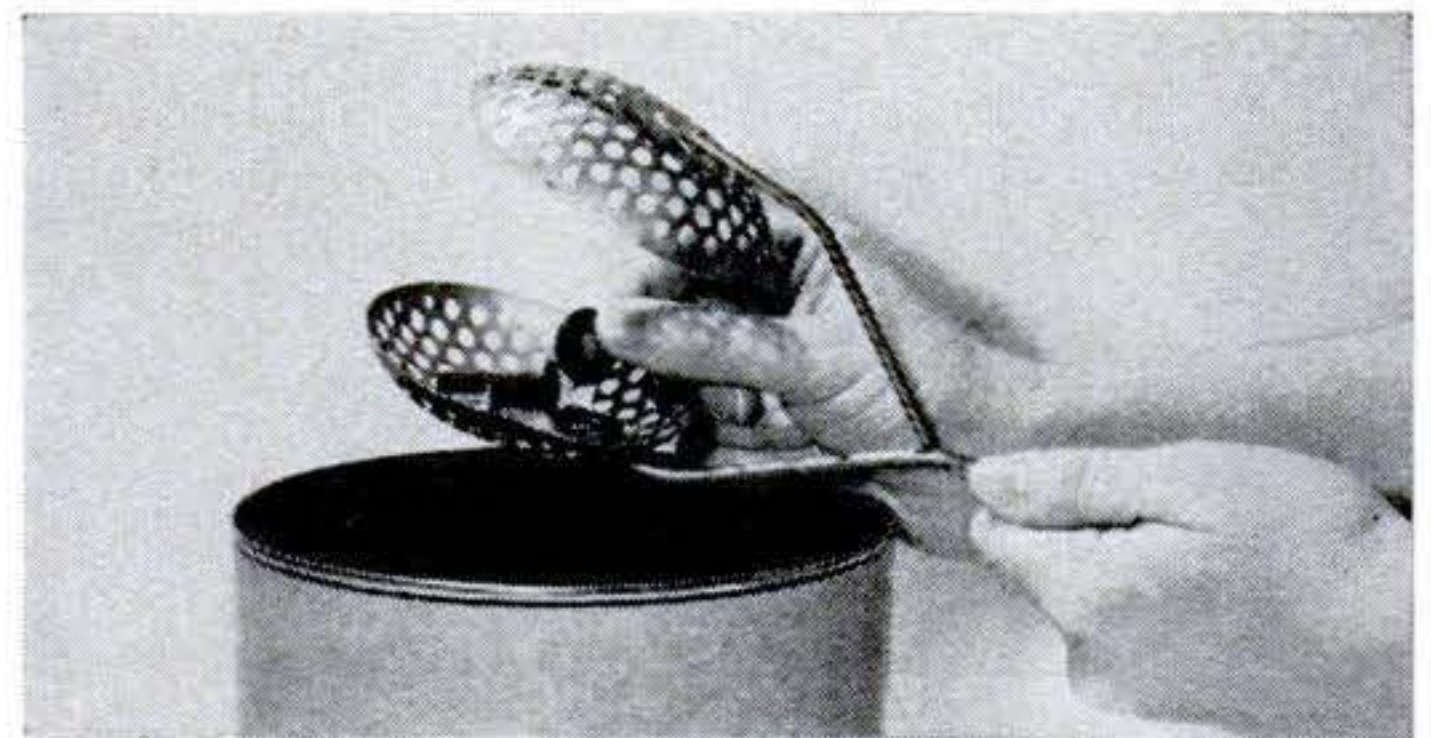

Small-Parts Cleaning Device

You can clean gunked-up bolts, nuts and small parts without wetting a hand.

Just drop them into a dime-store "soap saver" and swish the thing around in solvent. Even after an overnight soaking, it can be lifted and you won't have to fish for each part.—*Fred James, Nutley, N. J.*

Short Cuts and Tips

.....

▶▶▶ **BORROWED** tools will find their way back to you faster if they are identified with a broad band of paint on the handles. Use the same color on all—a house mark.—*Blanche Campbell, Riviera, Cal.*

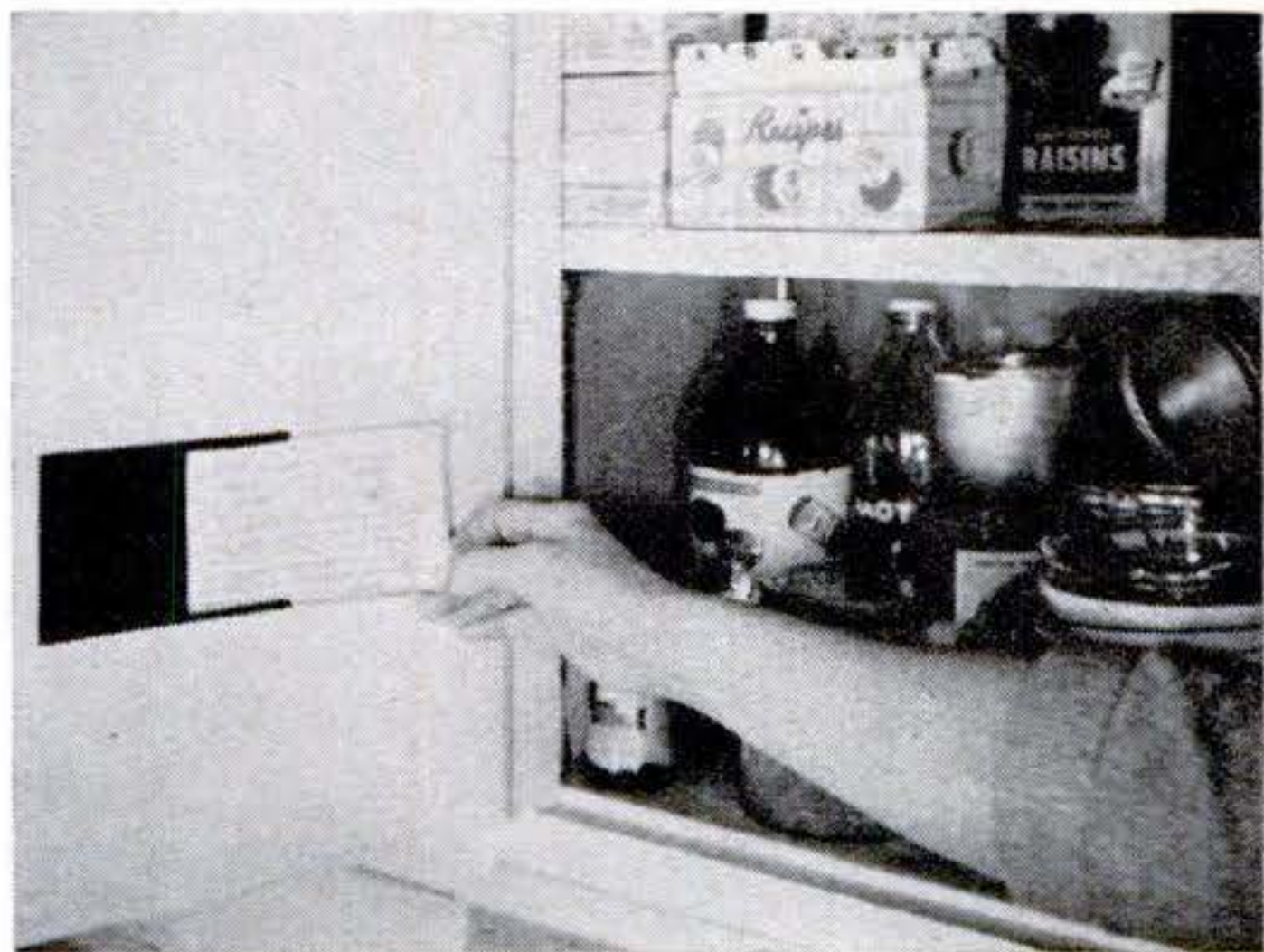

Cabinet-Door Recipe Holder

You can slide recipe cards in and out of this metal holder screwed to the inside of a cabinet door. I put mine on the door over the mixing counter.

Make the holder by bending guides on two opposite edges of a galvanized-metal or aluminum sheet a little larger than the cards used. Cards should slide easily.—*Arthur R. Tanner Jr., Poughkeepsie, N. Y.*

Extension-Cord Clamp Board

How often have you had a tool cord pull loose from an extension-cord socket when you were intent on a job? I made a clamping board to prevent this.

To 4"-by-8" scrap I screwed two heavy paper clamps. They hold both cords. The board, not the connection, takes the strain.—*John Mihalick, East Liverpool, Ohio.*



Stand for Hand Beater

MIXING batter, whipping cream, and similar kitchen chores are faster and less tiring if the beater has a firm support.

You can make a C-shaped stand like that above from $\frac{3}{4}$ " plywood. Attach the beater to the adjustable arm with screws driven through holes already in the appliance. The mixing bowl fits a shallow recess in the base.—*J. Bosma, Toronto.*

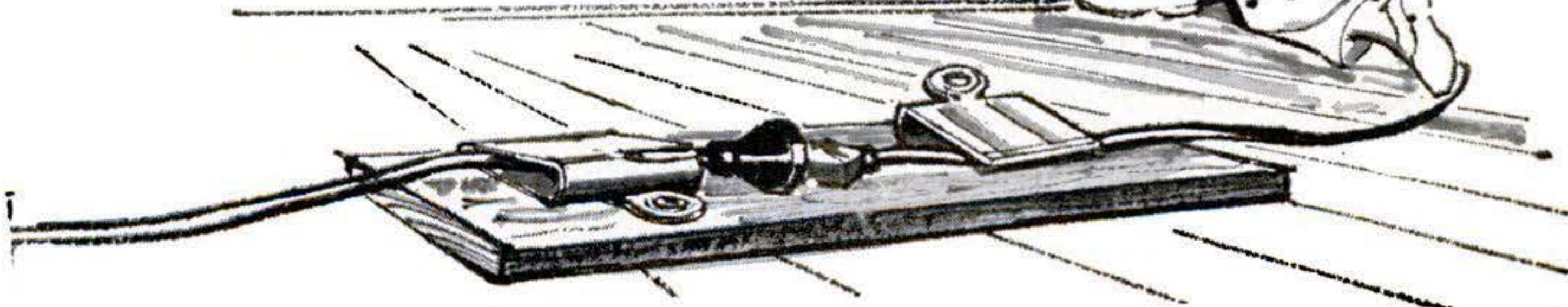

Short Cuts and Tips

.....

Hinged Pallets Fold Out of the Way

SMALL shops using pallets or other wooden platforms to store work on, often find the empty ones take up too much space. We solved this problem in our shop by cutting the pallets in half and hinging them.

The pallet rails were cut where the center boards meet and these boards were removed temporarily while the hinges were mortised in. A door bolt of the slide type was attached to each rail

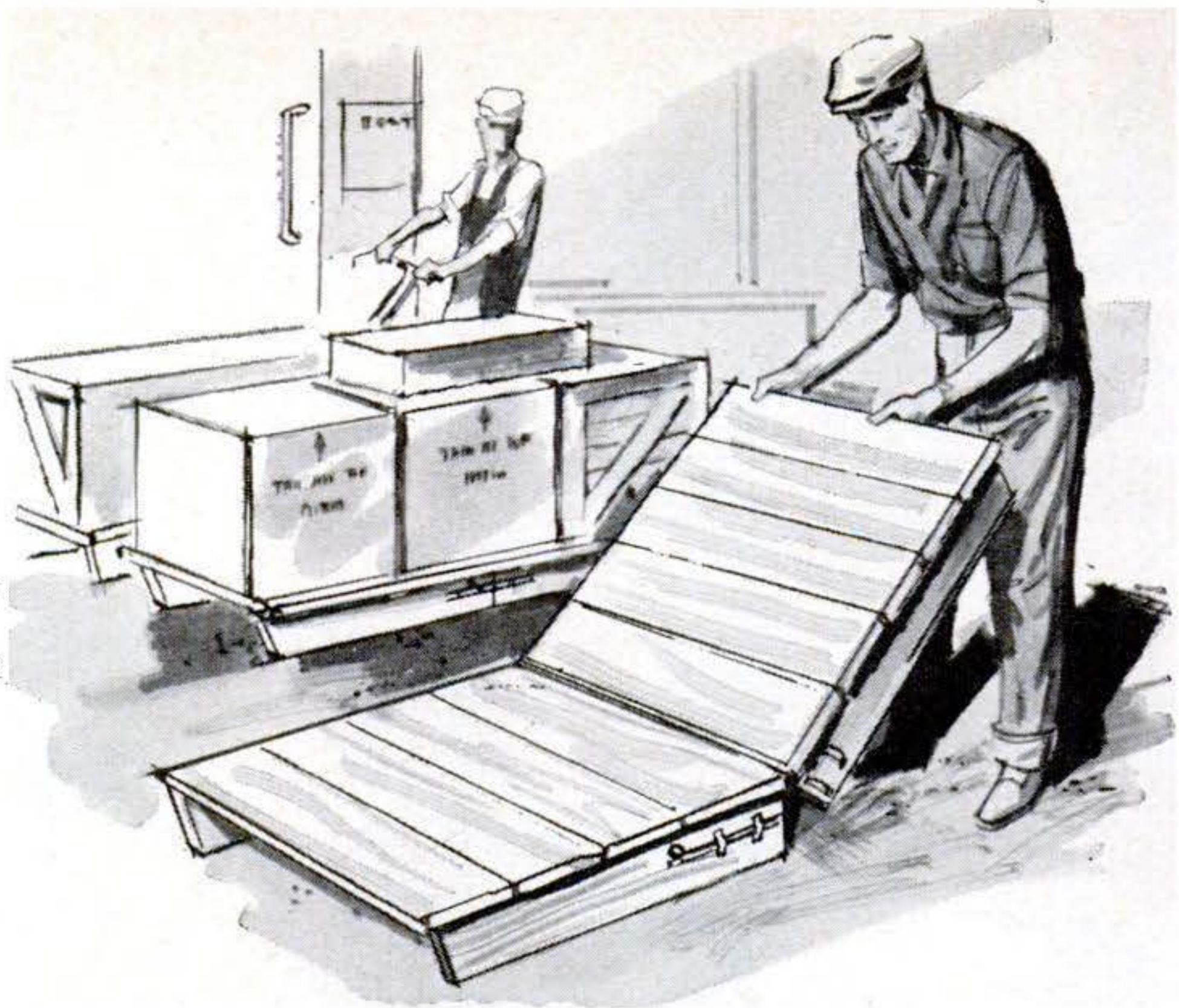

to hold the pallets rigid when they are open.—George Glavosek, Painesville, Ohio.

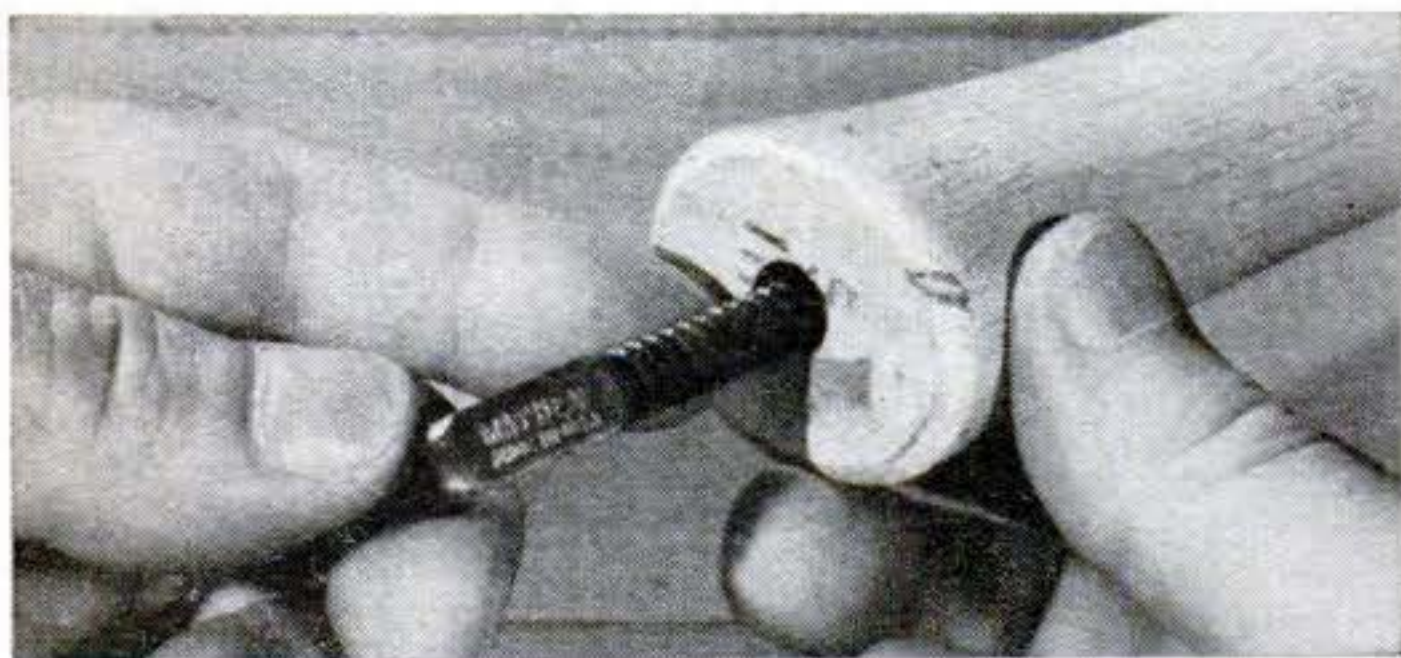

Nail Set in Handle of Hammer

So you will always know where that elusive nail set is hiding, drill a storage hole for it in the hammer handle. Choose a hole diameter that will make the large end of the nail set an easy push fit in the handle.—Kevin Murphy, Detroit.



Mortar Box for Small Batches

You can mix small batches of mortar or concrete—for pointing and patching jobs—in a clean, inverted lid of a garbage can. Set the lid in an open nail keg or box so that the handle won't make it wobble.—Ralph J. Ahrens, Neshanic Station, N. J.

Simple Decorative Candleholder

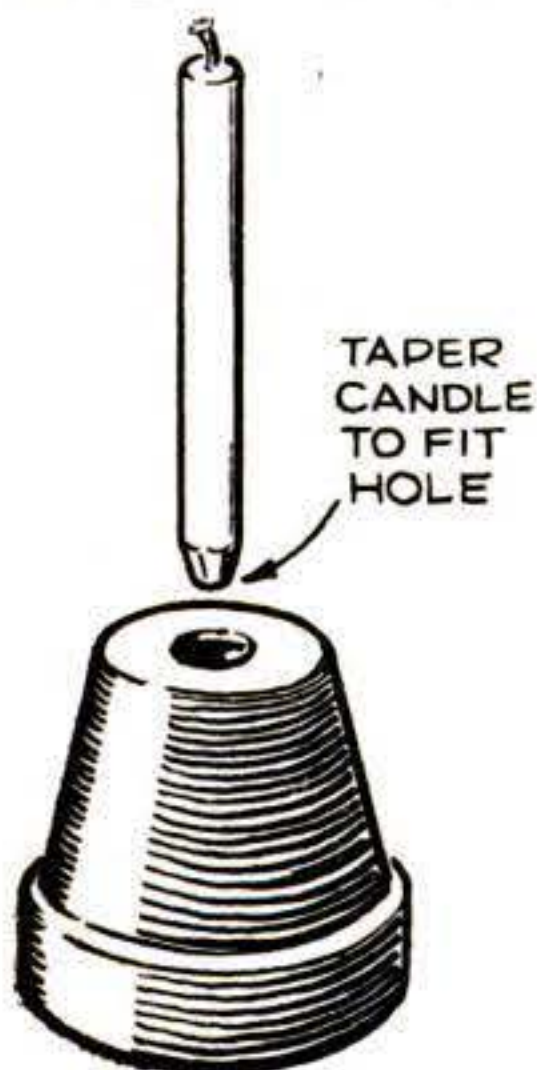

TURN a small flowerpot upside down, and you have an unusual patio candlestick. It can be painted for permanent use, or covered with foil or colored paper for parties.

Taper the candle end for a snug fit in the drain hole of the pot.—Fred Cornelius, El Paso, Tex.

Scaffold Nail Plugs Vent in Can

LARGE cans of oil or chemicals pour better with a vent hole in the top. To keep out dirt when the can is not being used, plug the vent with a scaffold nail, which has an easy-to-grasp head.

Punch the hole with the nail to get a snug fit.—R. Mathiot, Lake Grove, Ore.

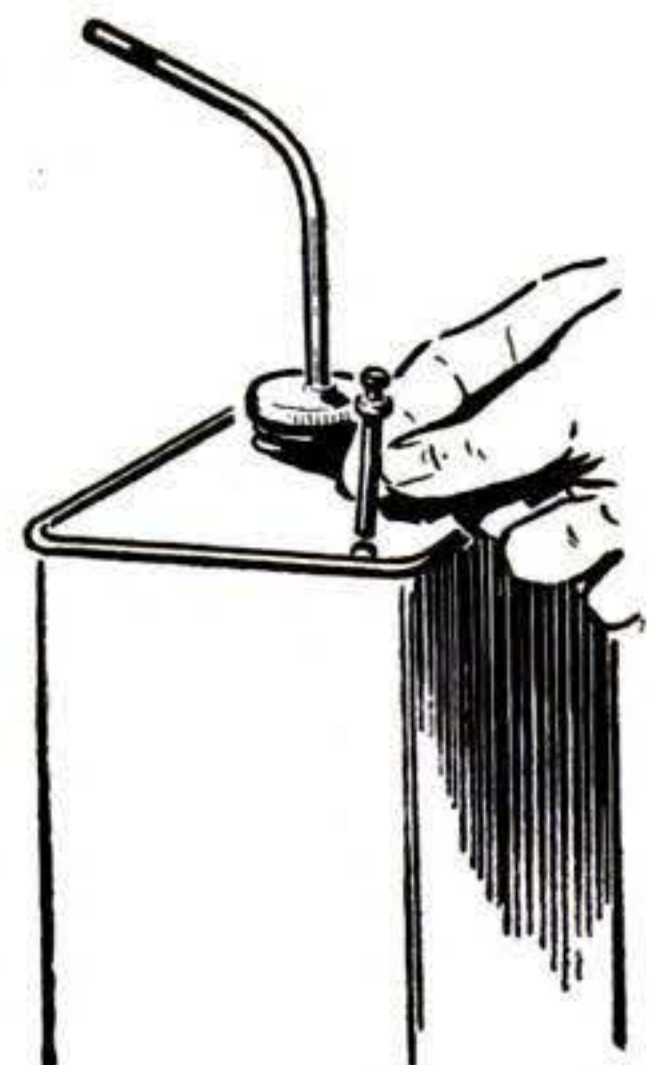

SIMONIZ MAKES IT

A TERRIFIC NEW CAR POLISH!

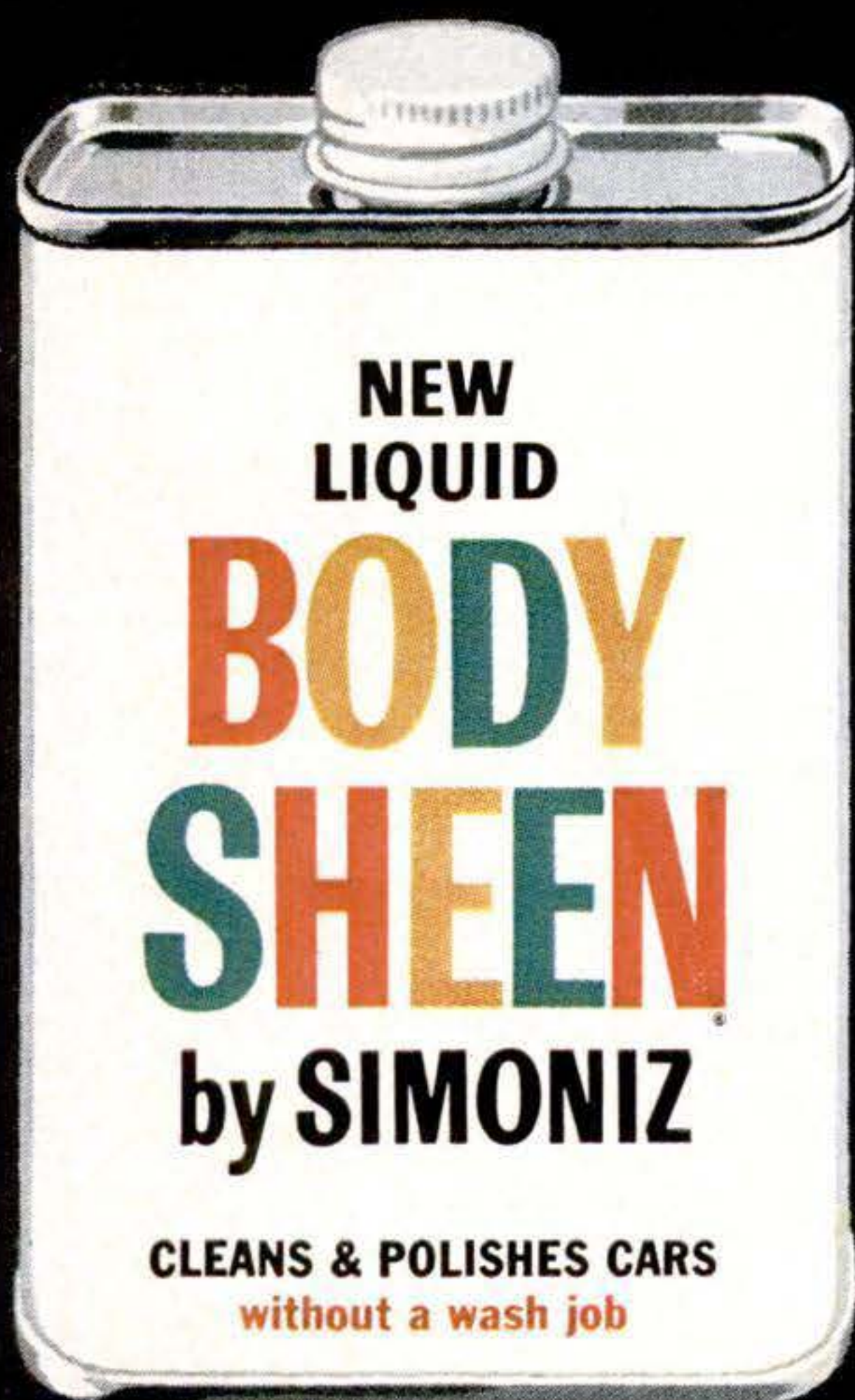

NOW — \$1.49

Short Cuts and Tips

.....

Transparent Work Top for Modelmaker

SLIP those model plans under a sheet of glass laid over the top of your work table. The plans lie flat where they can be read easily and the glass makes a smooth work surface.—*J. Cullen, Springfield, Mass.*

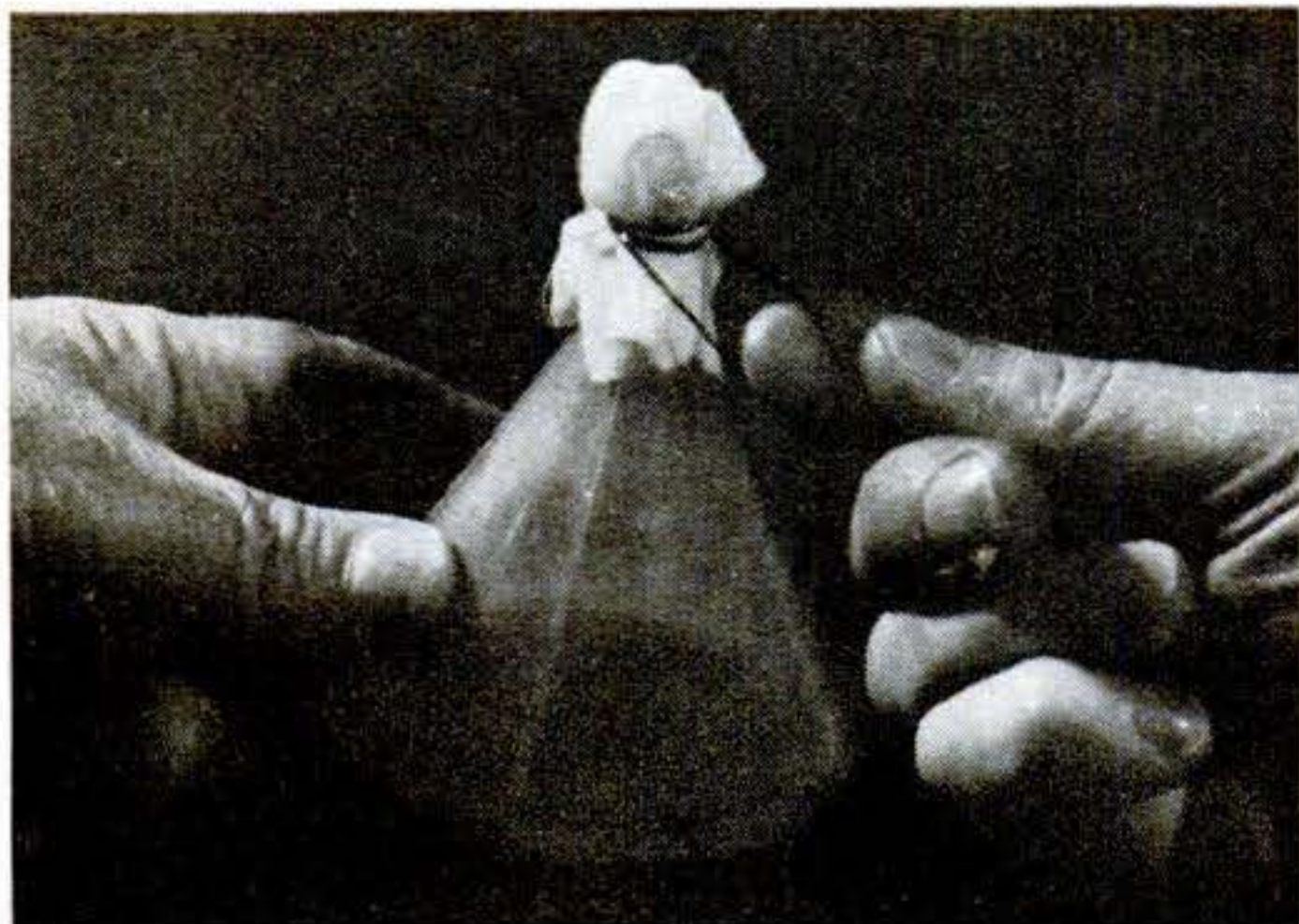
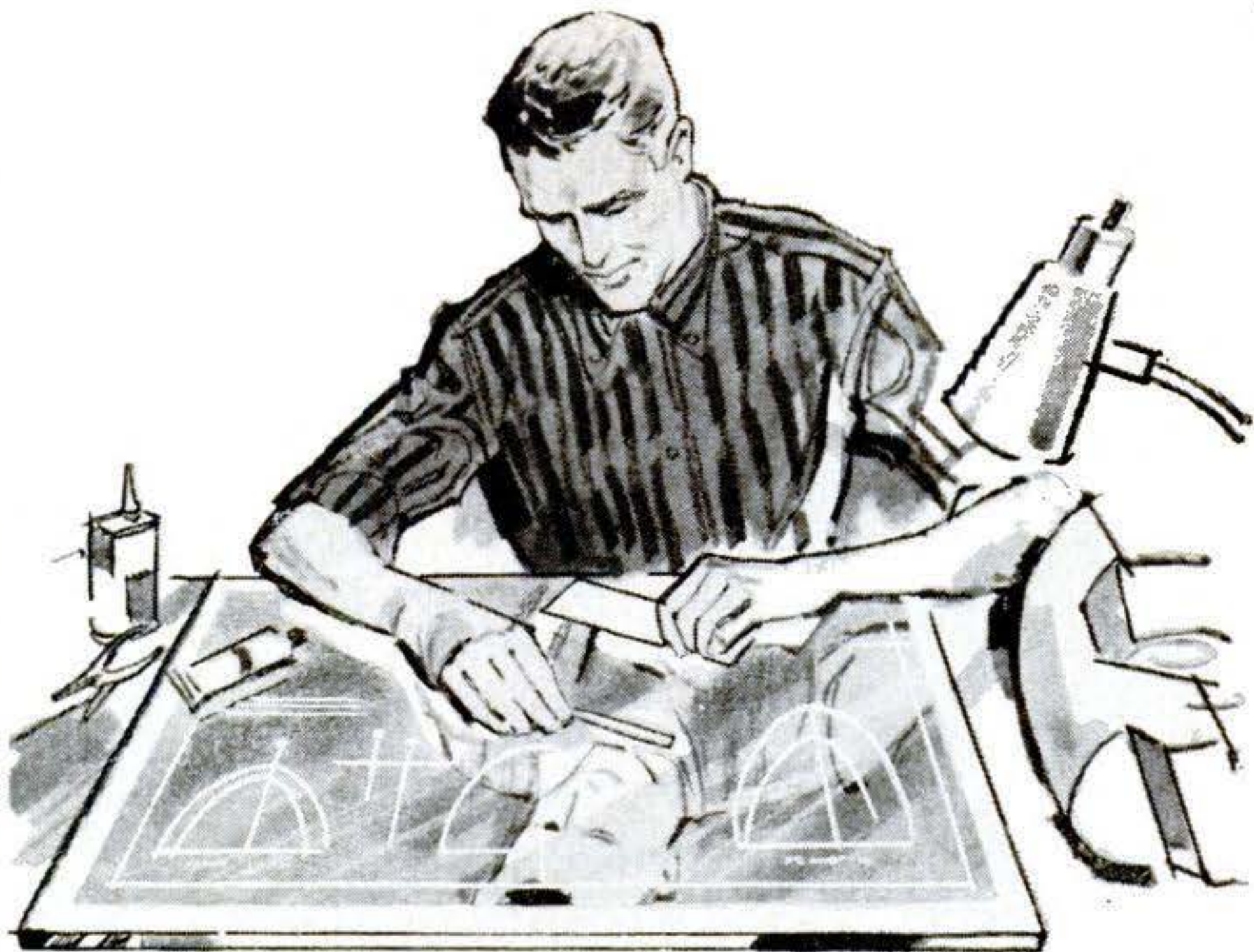

Here's a Speedy Filter

A PIECE of cotton flannel tied over the end of a funnel makes a fast filter for photo solutions and other chemicals. Let the flannel bulge at the bottom for best results.—*Ken Murray, Colon, Mich.*

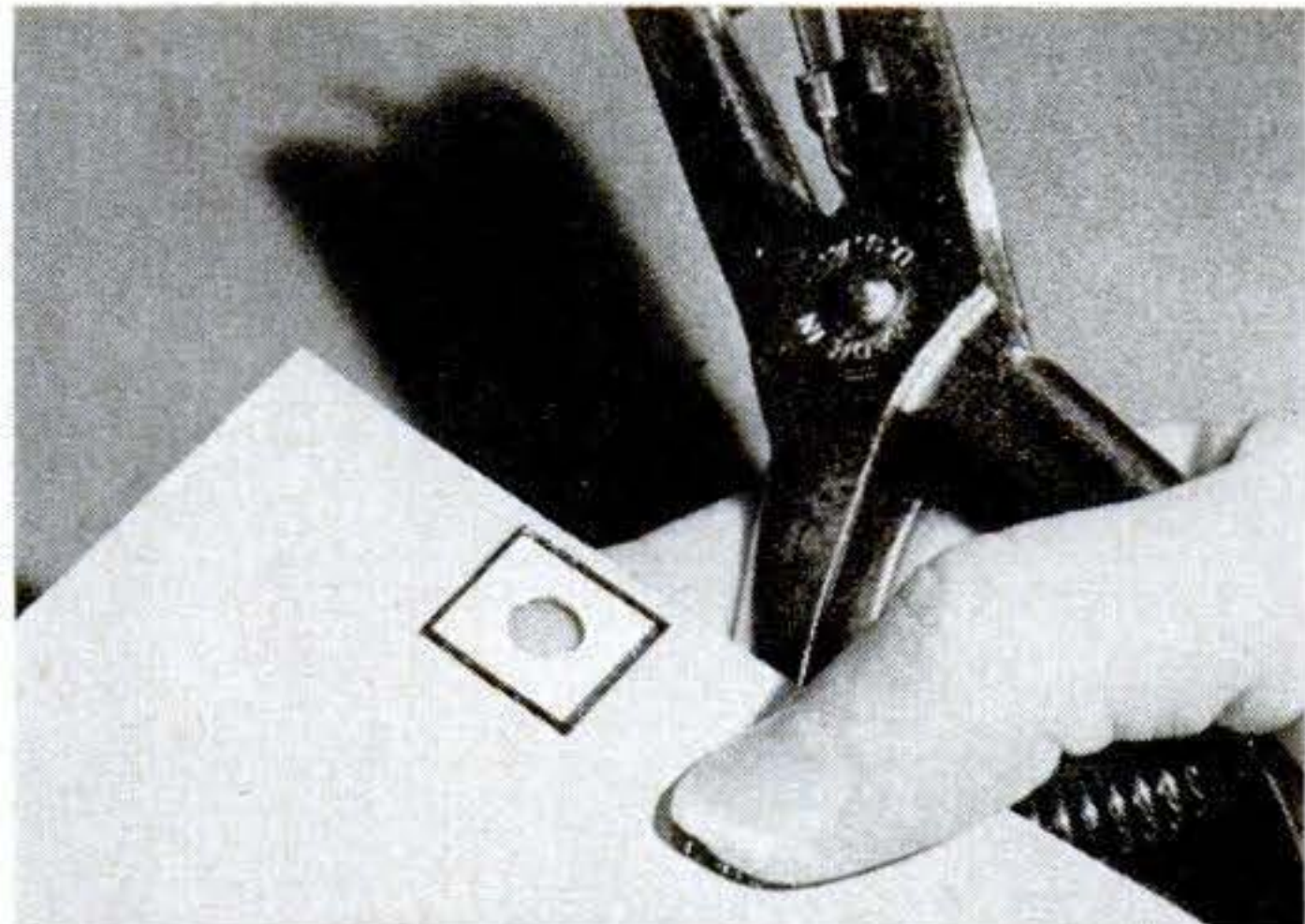

How to Reinforce Punch Holes

SMALL squares of adhesive-backed plastic, pressed into place and punched with the usual paper punch, make sturdy strengtheners for loose-leaf pages or clippings.—*Frank A. Javor, Newark, N. J.*

Water Intake for Lake Cottage

YOU can get clear lake water for a summer cottage by running the intake pipe to a simple protector. Weight a galvanized pail with small stones and set it on the lake bottom. Stick a fine-mesh filter screen into the end of the pipe and force the pipe between the stones. To pull the pail up for cleaning, hook its handle with a strong rake or boathook.—*L. A. Sovereign, Honey Harbor, Ont.*

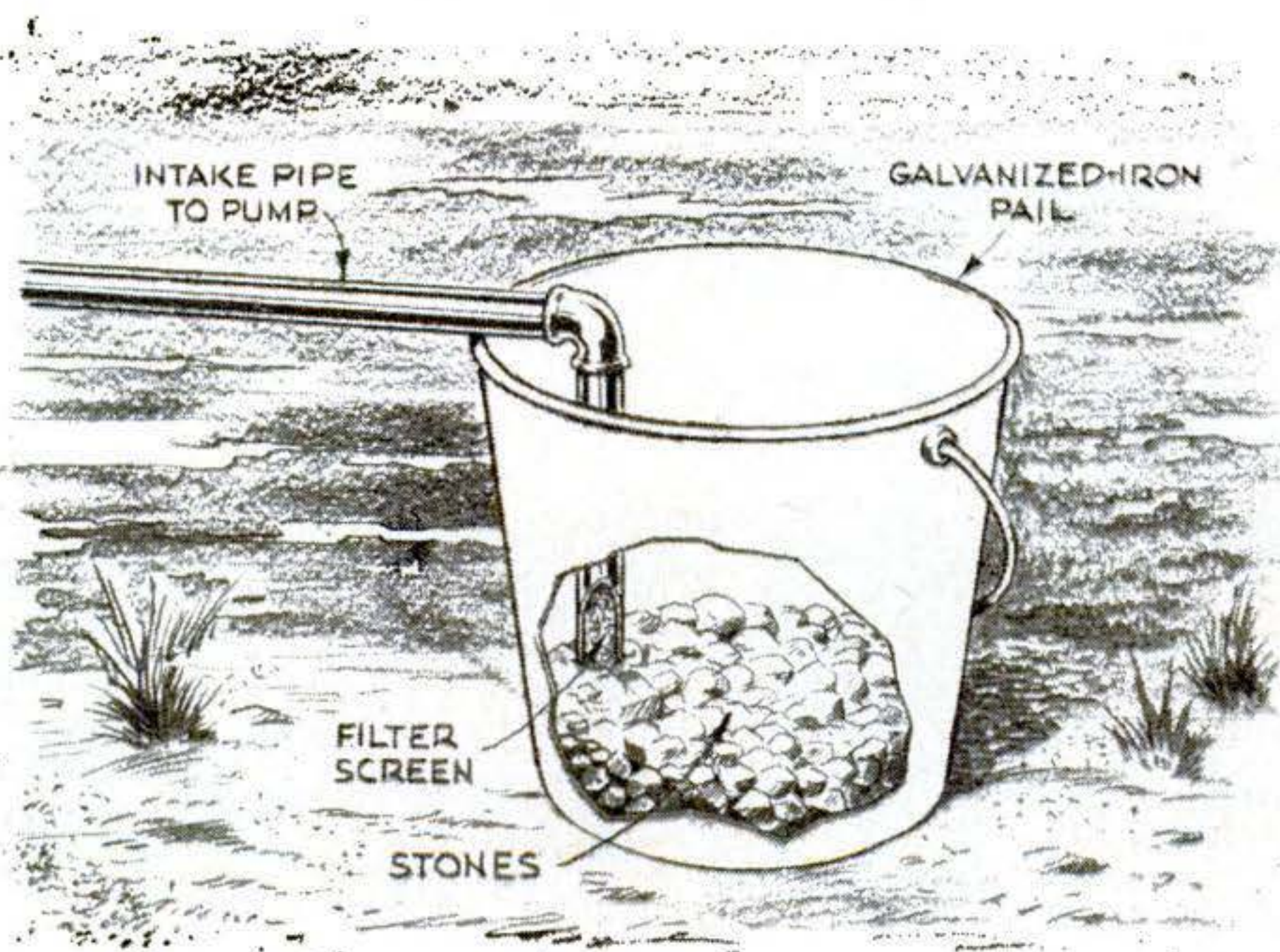

BRITISH SURPLUS AUTOMATICS

\$10

DEPOSIT



38 SUPER AUTO

Also .32 and .38 AUTOMATICS!

We have obtained a fabulous lot of brand new Llama BRITISH OFFICERS' AUTOMATIC PISTOLS in three calibers all with British proofhouse and royal ordnance marks. Equipped with British service lanyard ring. These are almost an exact reproduction of the famous Colt auto. Beautifully made, nothing has been spared in mfr. Limited supply. Pick your favorite caliber. U.S. made ammo for all three in any sporting goods store.

.32 ACP AUTOMATIC \$24.95
 .380 AUTOMATIC \$24.95
 .38 SUPER CAL. AUTOMATIC \$29.95

TO ORDER: Send \$10 deposit on any gun. Pay balance C.O.D. Shipped F.O.B. Los Angeles. 10-day money back guarantee. Fire and inspect, return for full refund if not satisfied. Enclose signed statement: "I am not an alien, never convicted of crime of violence or fugitive, am not under indictment, am 21 or over." Calif. resid. order through local dealer.

THE ELLNER COMPANY Dept. 33,
 1206 Maple Ave.
 Los Angeles 15, Calif.

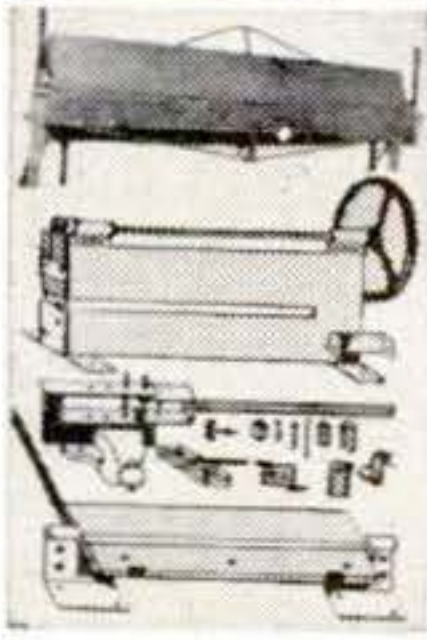

SHEET METAL MACHINES

Brakes form angles, locks, pans, etc. Quick eccentric clamp. All steel construction.

15"-16 gauge steel.....\$28.00
 36"-22 gauge steel.....\$37.00
 48"-24 gauge steel.....\$52.00
 Floor stand \$ 8.00
 15"-24 gauge Folder\$17.50
 36" Pan and Box brake.....\$60.00
 3/4 x 3/8 Adjustable Bender.....\$14.50
 16 gauge 7" Bench Shear 3 adj. gauge.....\$16.50
 Electric Shear, 24" reach.....\$48.00

ORDER DIRECT OR SEND FOR FREE CATALOG
 VYKE MFG. CO., N-4158 Jason St., Denver 11, Colo.

20 BOAT PLANS 75¢

Build the Boat of Your Dreams

Now you can build almost any type of boat—hydroplane racer, cabin cruiser, water bicycle, outboard runabout, sailboat, canoe, pram, dinghy—plus 12 other boats from the simple, easy-to-follow plans in our 192-page "Boat Builder's

Handbook" No. 554 on sale at newsstands, 75¢; or direct from: SCIENCE & MECHANICS, 450 E. Ohio St., Dept. 788, Chicago 11

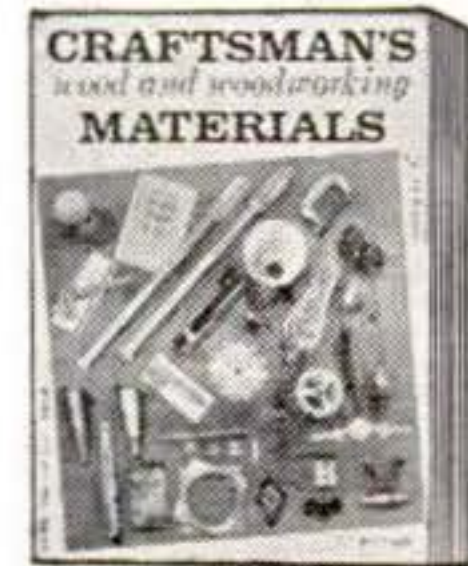

Get New 132 Page Catalog of WOOD AND WOODWORKING MATERIALS

WORLD'S LARGEST SELECTION—Lowest Prices
 Your buying guide for finest kiln dried domestic and rare imported woods, inlays, bandings, matched plywood, mouldings, ornaments, etc. Biggest selection of tools and hard-to-find hardware. Packed with scroll saw patterns, projects, wood facts and money making ideas. Enclose 25¢ (refunded on first order) to help pay mailing and handling costs. Write today to **CRAFTSMAN WOOD SERVICE COMPANY** 2729 S. Mary Street, Dept. B-7, Chicago 8, Ill.

Brand New! Portable Light Plants

Push Button Start! Available from 700 to 3500 watts (continuous duty) 115 volt AC power for trailers, camps, etc. CD approved. 12 volts DC (or 6 volts small units) for battery charging. No surplus parts used. New long life engines, fiber glass insulated generators. Other features available—Remote control, fully automatic, and "No Load Idling."



Order today or write for details. COD order 25% deposit. 700 watts (A712) 77 lbs.....\$143.50
 1000/1200 watts (A1012) 90 lbs.....\$195.50

Easy Terms Available

General Electronic Service Corp.
 P.O. Box 9 Burlington, Wisconsin

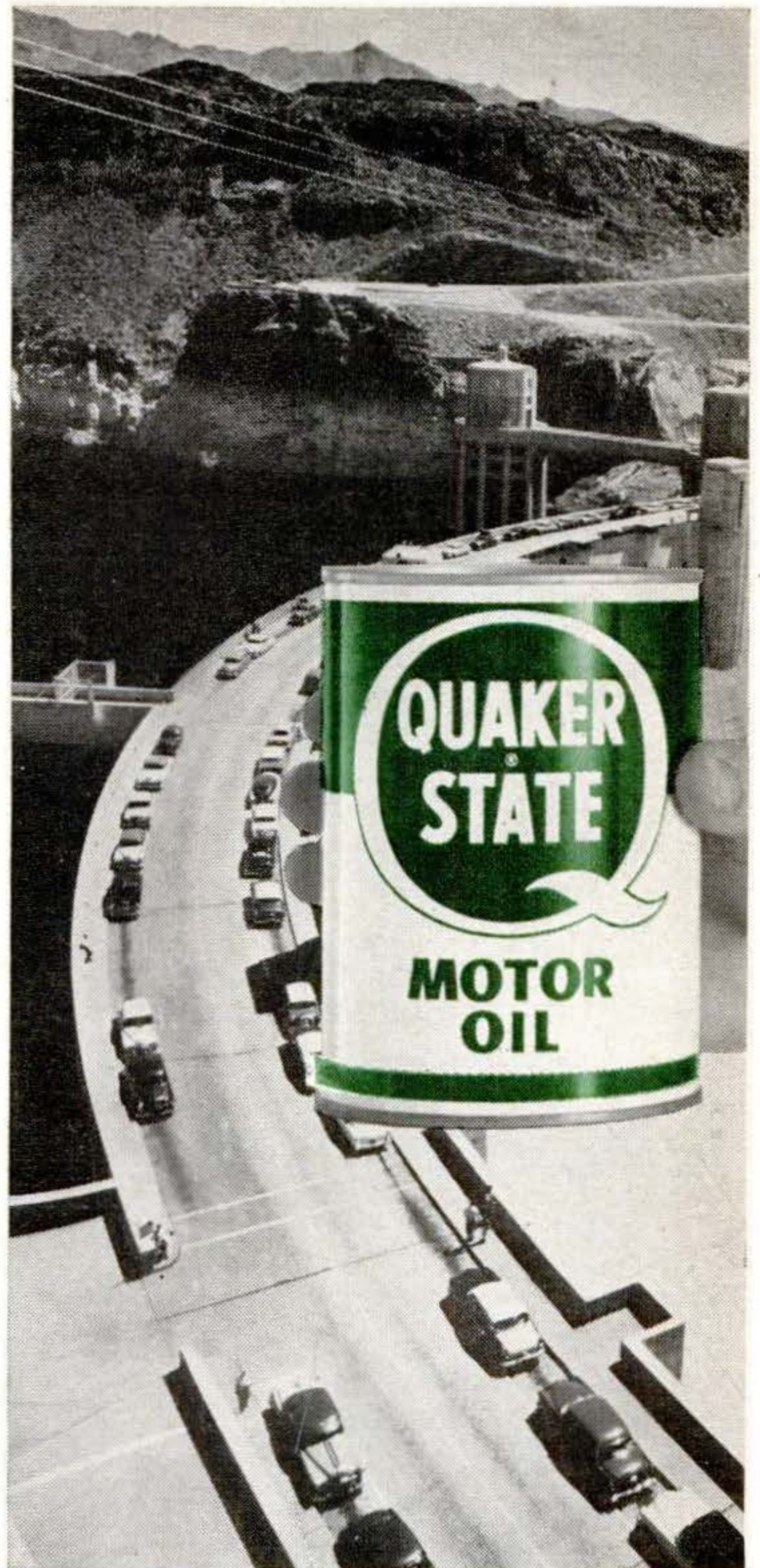

HOOPER DAM, COLORADO

Big news on the road today is Quaker State . . . This highest quality pure Pennsylvania motor oil keeps engines clean, gives longer-lasting, more economical engine lubrication in *any* season under *all* driving conditions. Wherever you drive, always ask for **Quaker State** . . . *it's the best motor oil money can buy!*

QUAKER STATE OIL REFINING CORPORATION, OIL CITY, PA.
 Member Pennsylvania Grade Crude Oil Association

Short Cuts and Tips

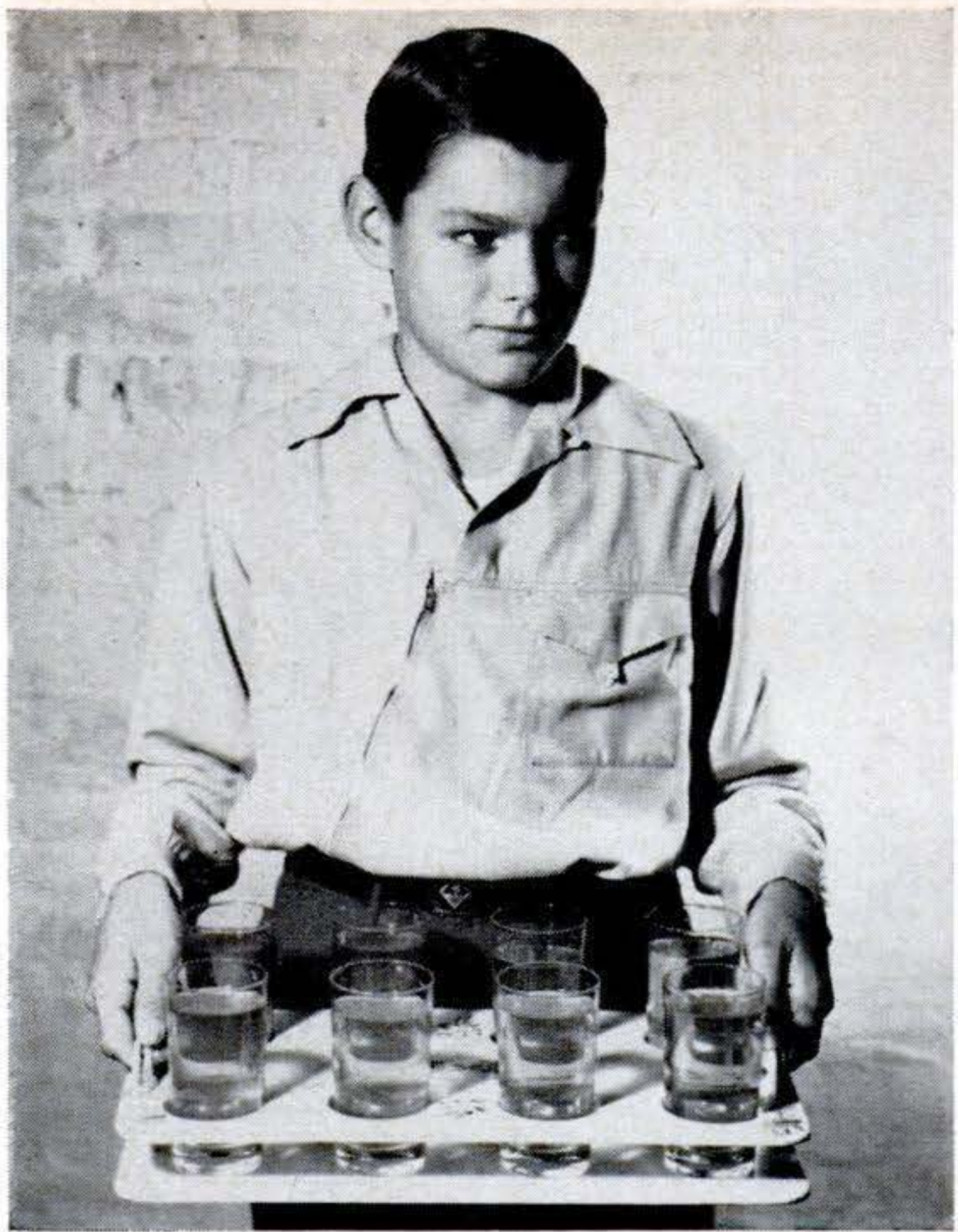
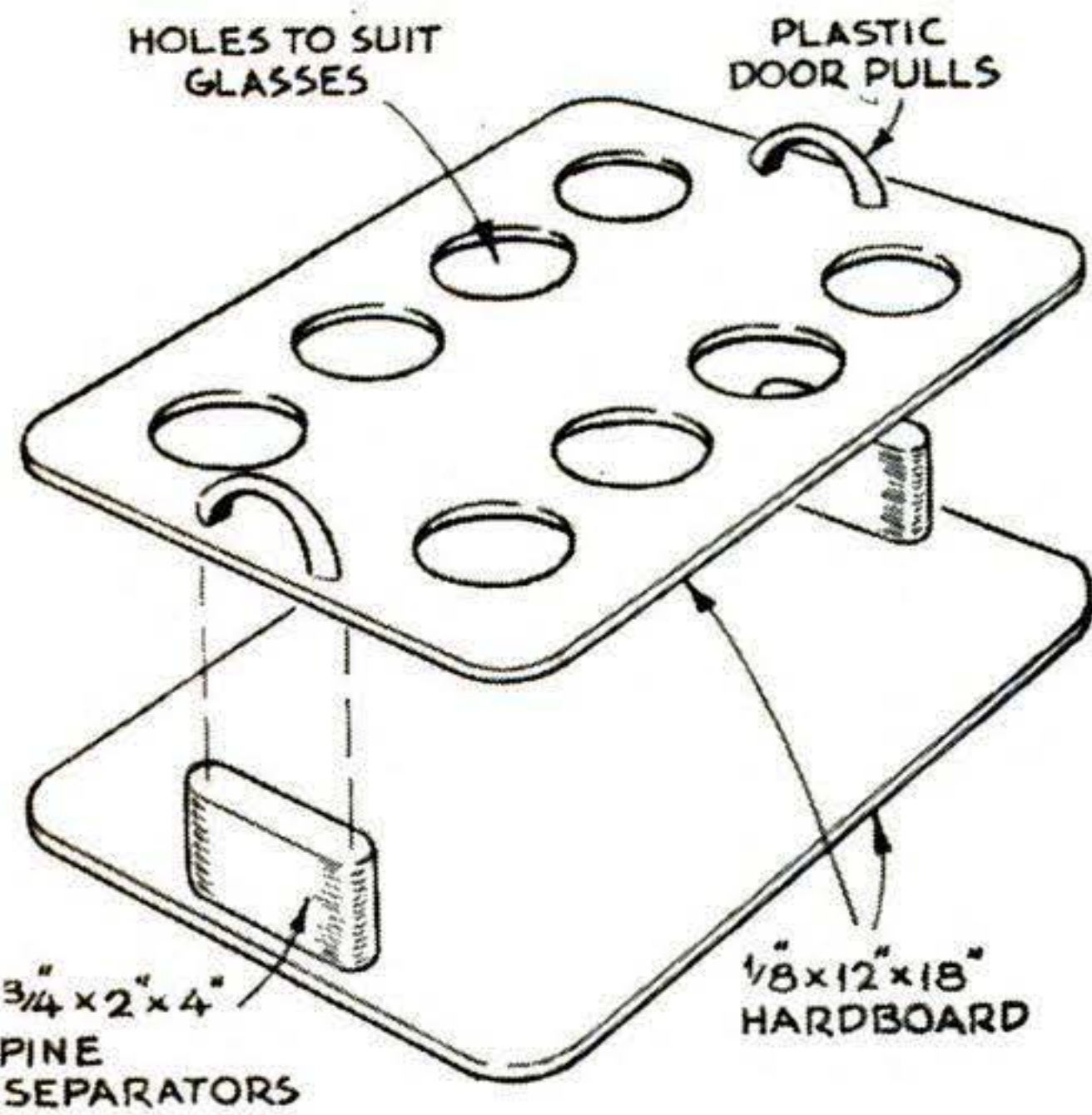

Door Pulls Make Tray Handles

THIS serving tray carries eight large beverage glasses without spills or skids. Two 12"-by-18" pieces of $\frac{1}{8}$ " hardboard are spaced 2" apart, one over the other. Just screw on two replacement door pulls, of the kind used on kitchen cabinets, for decorative tray handles.

Scribe circles on the top panel, using an inverted glass as a guide. Cut out the holes with a scroll saw or electric hand-saw and smooth rough edges with a file and sandpaper. These Presdwood panels and wood spacers had a primer and two high-gloss finish coats of paint before being fastened together. You can decorate the top by painting on a design.

Cut Out Circles on Your Table Saw

THIS jig holds work *beneath* it on the table saw while you neatly cut disks out of square stock. Drill a hole for a $\frac{1}{2}$ " dowel or steel pivot pin through the jig board and the stock. Screw a wood block to one end of the jig and clamp it to the saw fence with the work in position and the saw blade fully retracted. Adjust the fence to locate the pivot the required distance (the circle's radius) from the blade. Clamp the free end of the jig to the table, using a spacer beneath it to keep the stock from binding. Turn on the saw and raise the blade to cut into the wood about $\frac{1}{4}$ ", then rotate the work one

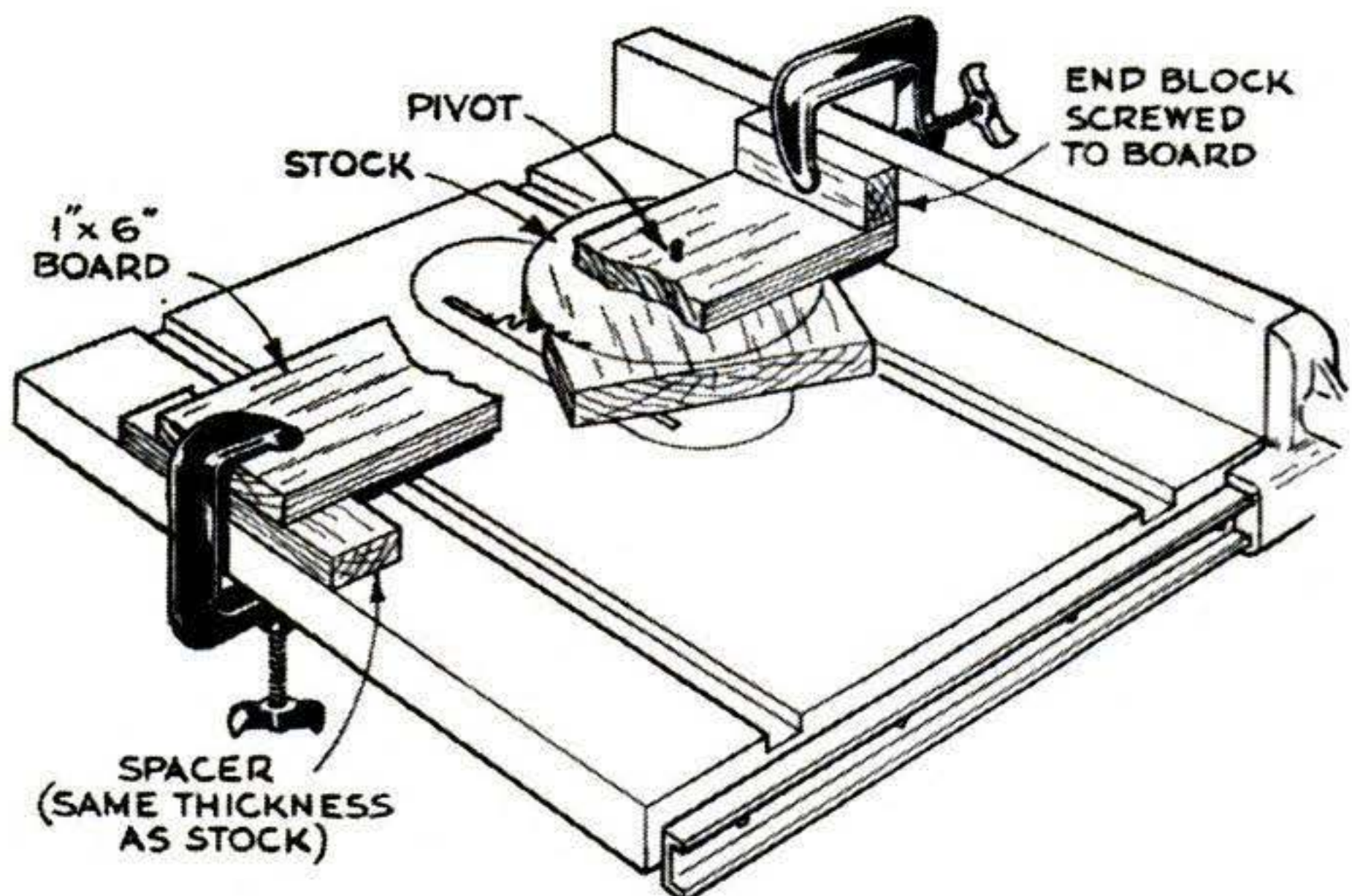

full turn. Continue raising the spinning blade $\frac{1}{4}$ " at a time and rotating the work over it until the disk is cut through and the corners of the stock fall free of it. —A. W. Stinton, Brush, Col.

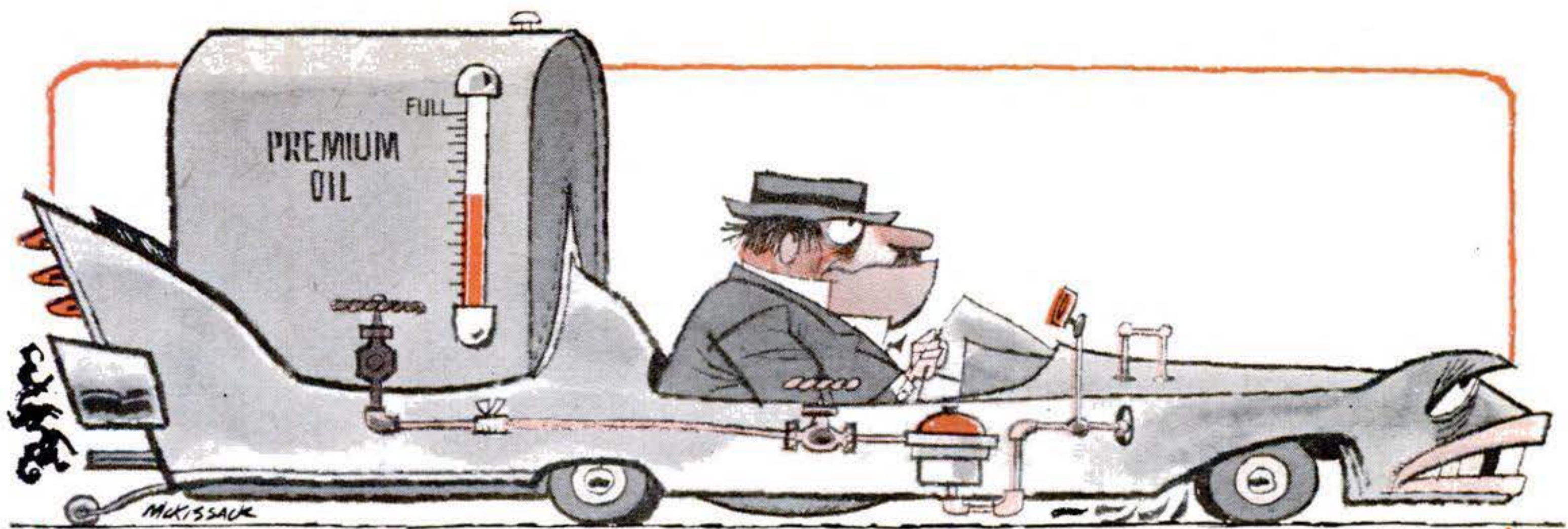

Using too much oil?... call for HASTINGS

Excessive use of oil is your first sign of worn-out piston rings. And worn-out piston rings mean power drop-off—costly wastage of gas and oil—expensive repairs later on.

See your motor specialist the minute oil-pumping warns you there's trouble ahead. When he recommends new piston rings, ask for Hastings. They're engineered exclusively

for replacement service . . . to stop oil-pumping, save gasoline, restore lost performance.

Get new car performance from your present car—with Hastings. Truly your best investment for thousands of extra miles of trouble-free driving. Hastings Manufacturing Co., Hastings, Mich. Piston Rings, Casite, Wear Reducer, Oil Filters, Spark Plugs

TOUGH ON OIL-PUMPING
GENTLE ON CYLINDER WALLS

U. S. PATENT NOS. 2614899, 2712971



HASTINGS PISTON RINGS



10" TILT/ARBOR SAW BUILD-IT-YOURSELF from GIL-BILT KITS-PLANS

Sturdy wood, steel, and aluminum construction. NEW DEPARTURE ball bearings. Capacity and performance of floor saws selling for \$150.00 and up. Plans, all metal parts in kit with 10" comb. blade \$25.90, less blade \$22.95. F.O.B. St. Louis. Detail PLANS-PATTERNS only \$1.00 postpaid.

Build-it-yourself 12" and 18" Bandsaws. 6" Belt Sander, Shaper. Simplified plans, build easily with hand tools only. Advertised and sold for 11 years, over 33,000 units in use. Money back Guarantee. FREE CATALOG.

GILLIOM POWER TOOLS, Dept. 70-G, Lambert Field, St. Louis 21, Mo.

Pack up your troubles with a SIOUX drill kit..

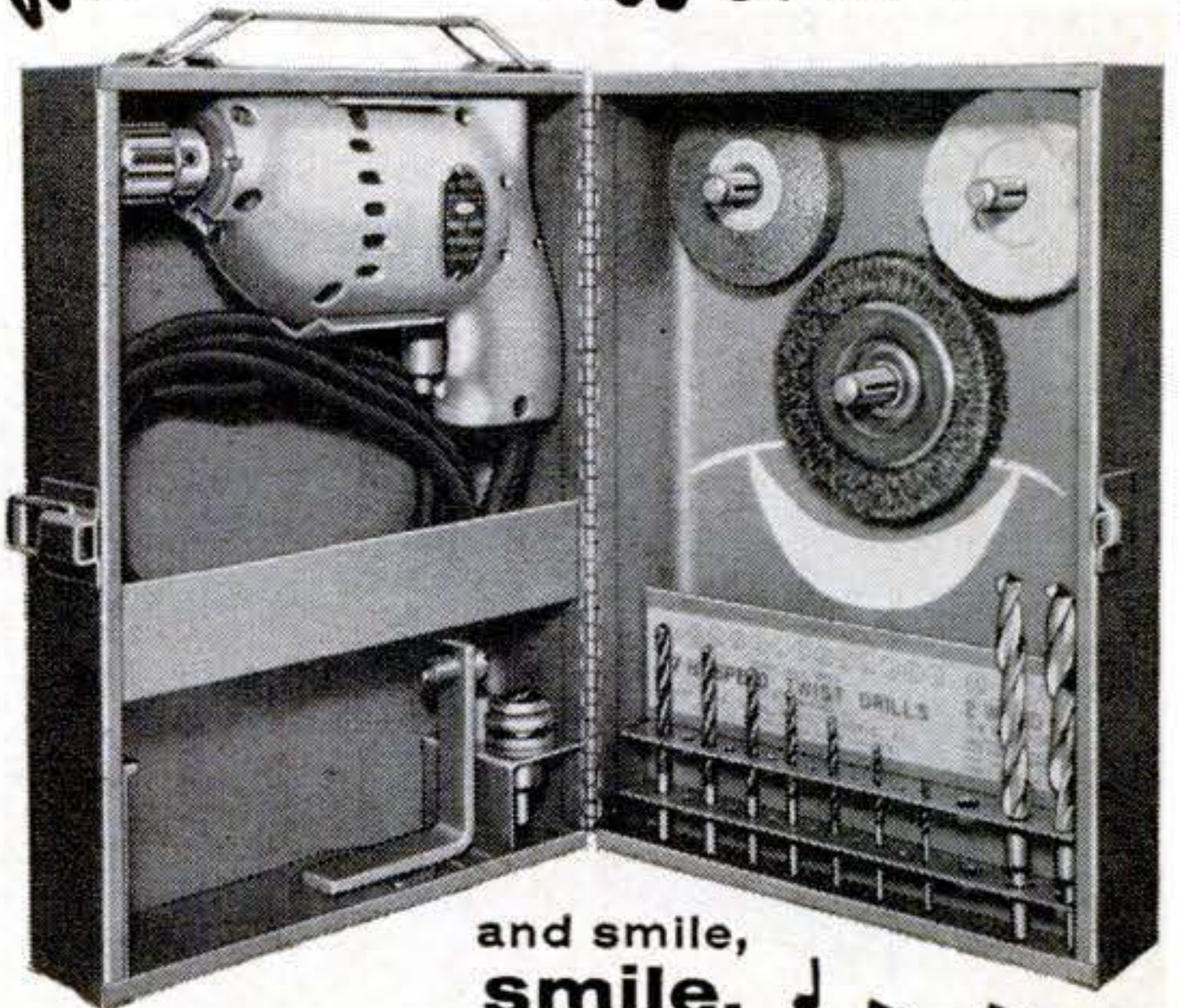

and smile,
smile,
smile!



Here is power that won't let you down. Power for grinding, drilling, wire brushing, polishing and cleaning . . . all in a kit that's handy to hang or haul to the job. Complete kit \$47.35. Drill only \$28.50.



CHECK THE YELLOW PAGES OR WRITE TO

ALBERTSON & CO., INC. • SIOUX CITY, IOWA, U.S.A.

JULY 1958 195

NEW! for 4-wheel drives
FREE-LOCK
Auto-Lock HUB



The Hub a Child can engage

Willys • Dodge • GMC • International • Ford
Chevrolet • Land Rover • Marmon Herrington

A revolutionary advancement. Merely set arrow to "in" position and Walk away! It's simple, safe, sure! Ruggedly constructed of finest tool steel by aviation precision standards. Fully guaranteed 1 year.

If dealer cannot supply, write for literature and prices

FREE-LOCK CORPORATION

6301 NORTH FEDERAL BLVD., DEPT. B • DENVER 21, COLORADO

Short Cuts and Tips

Drill Cradle from Coat-Hanger Wire

MY PORTABLE electric drill can be hung up with one hand in a cradle bent from a wire hanger.

The wire, rigidly stapled to an overhead joist, grips the drill at its vent slots to keep it from slipping.—*Harry Louden, Sarasota, Fla.*

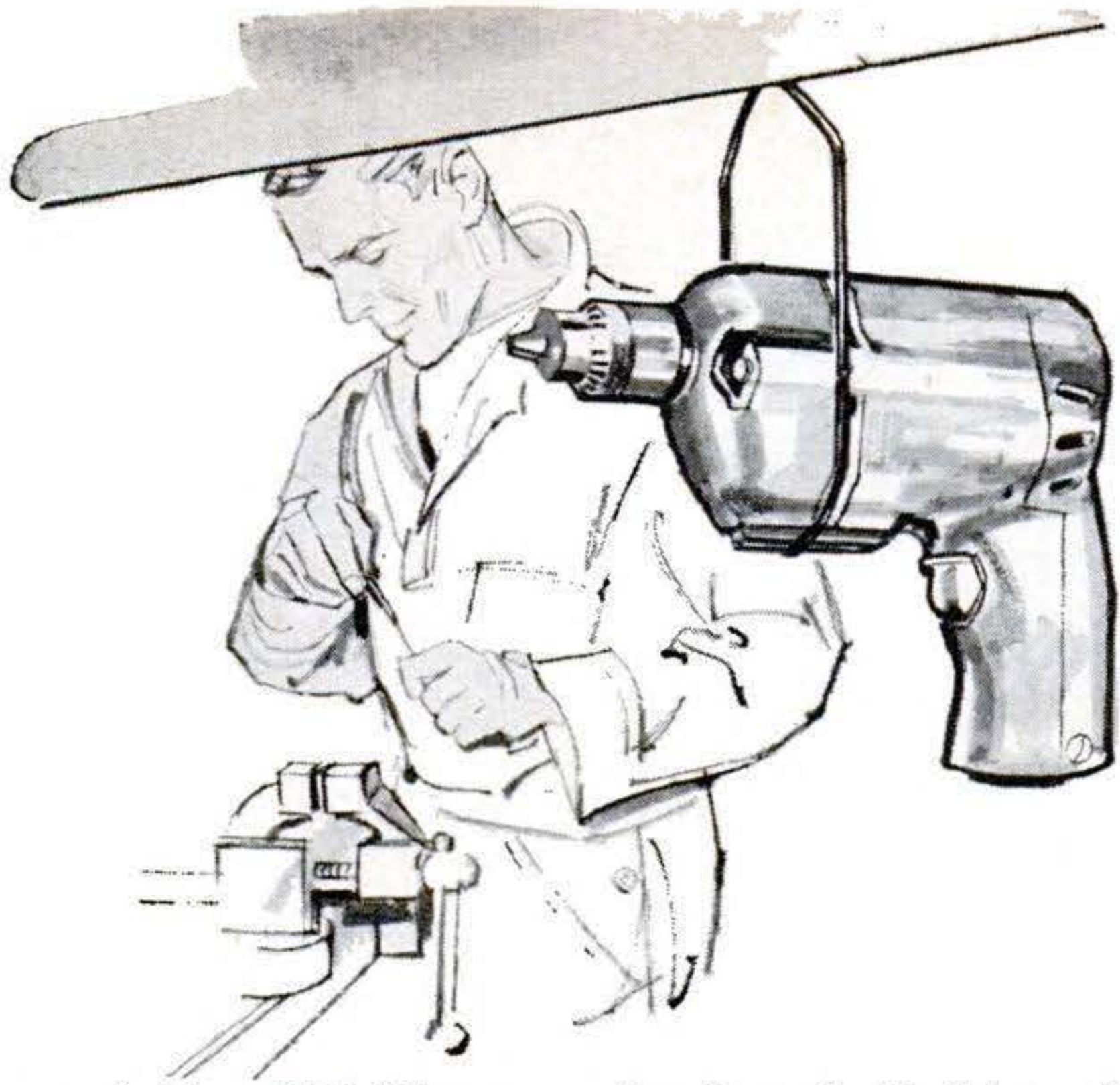

▶▶▶THE 12 compartments in a rigid, paper-fiber egg box will hold small parts from a motor or machine that is being torn down. Write the name and location of each of the stored parts on the lid so that when you close the box the identification will be right over the enclosed part. This will simplify reassembly and prevent loss.—*Lewis R. Walton, Arlington, Cal.*

▶▶▶WHEN sawing boards that have been used for concrete forms, the smart carpenter sets his portable-saw blade about 1/32" less than the thickness of the material and saws from the side that is clean. This way, there's no risk of dulling the blade by cutting into dried concrete. The remaining sliver of wood is easily broken away.—*Ned M. Perkins, Orange, Tex.*

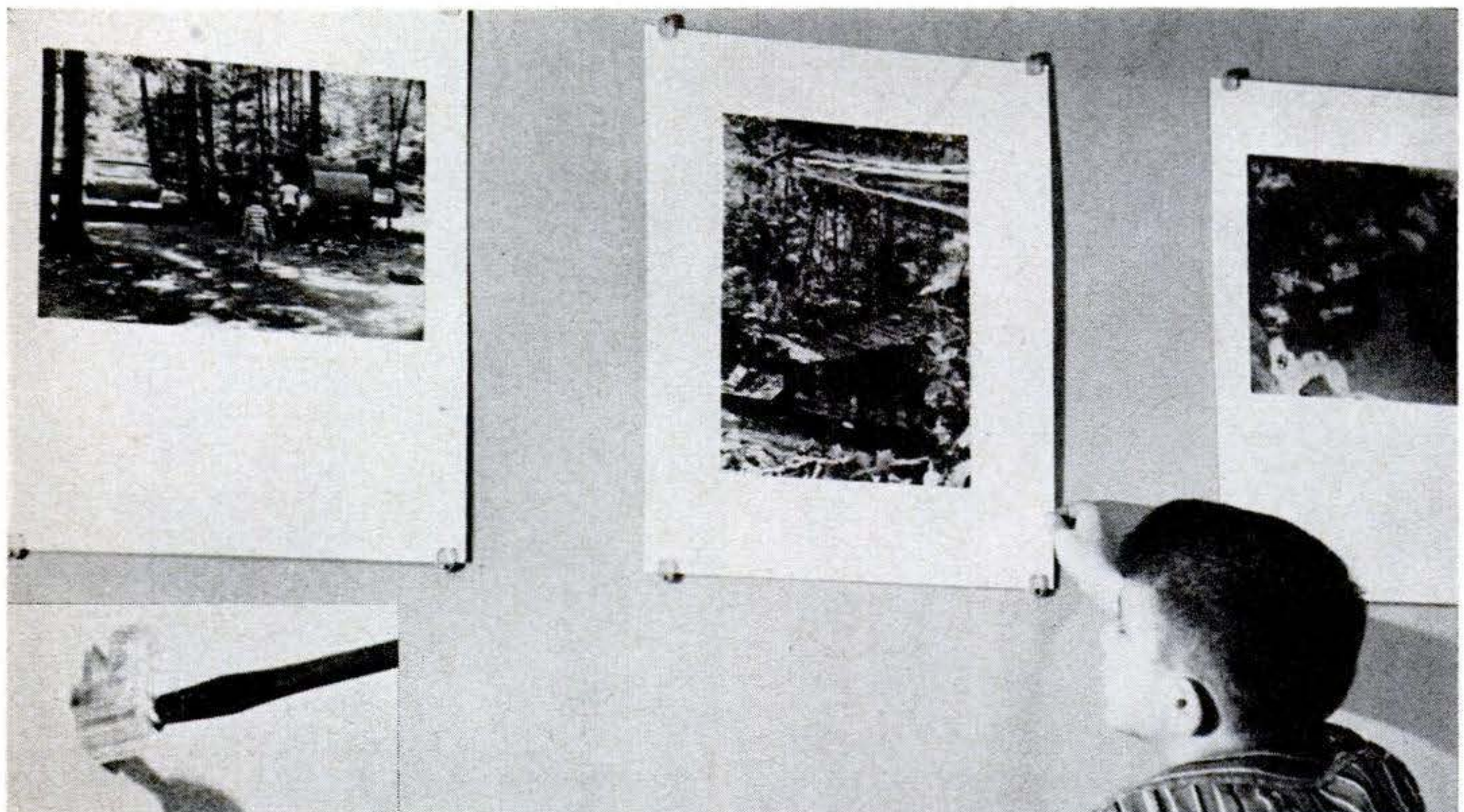

Easily Changed Photo Gallery

THE plastic brackets that hold a wall mirror in place will also hold a display of your favorite photographs. Mount the

prints on salon display boards and screw four mirror brackets to the wall for each board. Changing photos is simple because the mounted photos slide in and out easily.—*Glenn S. Hensley, Columbia, Mo.*

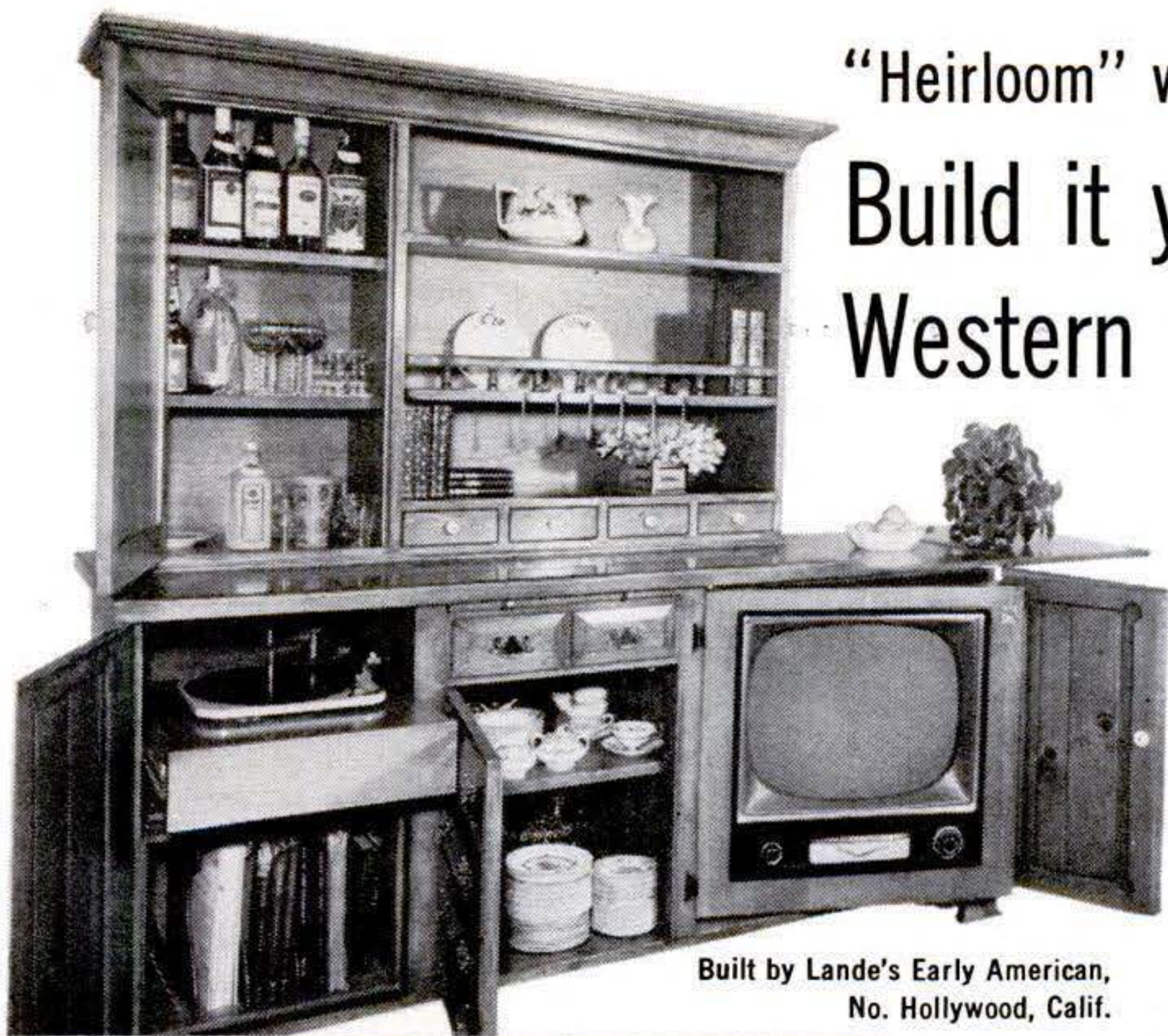

"Heirloom" with modern storage space... Build it yourself with Western Pine Region woods

Here's a piece of furniture with all the storage space you could ask for. Turn it out easily and economically with Western Pine Region woods.

Straight-grained, soft-textured, they're easy to work. Thoroughly dried and seasoned, they take any finish, or can be waxed and rubbed to a natural glow.

Choose from ten Western Pine Region woods for your next remodeling or furniture job. Your lumber dealer can suggest the correct wood to give beauty and value you can be proud of.

Built by Lande's Early American,
No. Hollywood, Calif.

FREE! 6 FINISH BOOKLETS... feature unusual **COLOR AND TEXTURE** ideas for finishing Western Pine Region woods in traditional or contemporary designs. Plus tips on installing, sanding, painting or staining these distinctive woods. Write to **WESTERN PINE ASSOCIATION**, Dept. 308-L, Yeon Bldg., Portland 4, Oregon.



Western Pine Association

member mills manufacture these woods to high standards of seasoning, grading and measurement

Idaho White Pine • Ponderosa Pine • Sugar Pine
White Fir • Incense Cedar • Douglas Fir • Larch
Red Cedar • Lodgepole Pine • Engelmann Spruce

Today's Western Pine Tree Farming Guarantees Lumber Tomorrow

(Item 24)



700 Watt Light Plant **PUSH BUTTON START**

115 v. 60 cyc. AC Powered by a rugged 2.2 HP, easy starting Briggs engine. No wiring necessary; just plug in and operate. Plenty of current for any oil burner, freezer, brooder, emergency lights, etc. which require up to 700 watts. Ideal for television and radios. Complete with voltmeter and built-in winding to charge 6 v. auto batteries. (Item 24) Wt. 75 lbs. Easily fits in car trunk. Be prepared if storm knocks out power lines.

Reg. \$275..... **\$143.50**

1200 Watt Plant (Item 45) same as Item 24 but larger generator and engine with 50% greater output..... **\$199.50**

We make all sizes up to 25,000 watts. Send 10c for catalog

MASTER MECHANIC MFG. CO., Dept. B-78, Burlington, Wis.

"MINIATURE MACHINE SHOP

No Bigger Than A Typewriter, Outperforms Machines Many Times its Size!"

That's what Mechanix Illustrated says about UNIMAT in their 3 page feature story in the May issue. If you want a reprint of this story plus complete information about this amazing 10 in 1 combination precision tool write to:

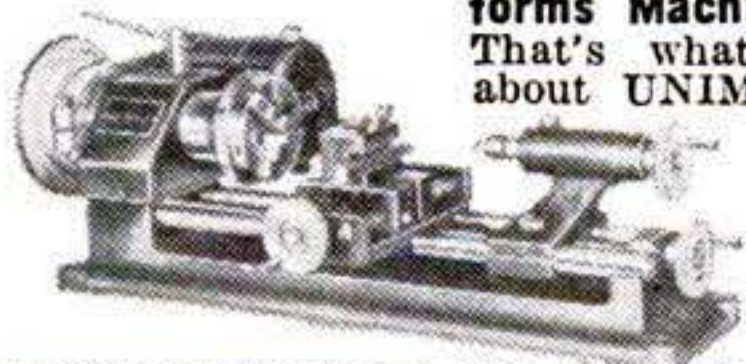

AMERICAN EDELSTAAL, INC., UNIMAT DIV., Dept. 178, 350 B'Way, N.Y. 13

A MICHIGAN PROPELLER MATCHED TO YOUR OUTBOARD MOTOR, BOAT AND LOAD

**GIVES BETTER PERFORMANCE
FOR SKIING, SPEED, CRUISING
or GENERAL OPERATION**

Send postcard for 1958 catalog (FREE). Contains much helpful boating data and carefully engineered propeller recommendations; also fine line of skis, boat accessories.

**MICHIGAN WHEEL CO., Dept. PS-7
GRAND RAPIDS 3, MICH.**



DON'T THROW IT AWAY — FIX IT WITH

Plastic Steel® 80% STEEL

AS EASY TO USE AS MODELING CLAY. Hardens in two hours — holds permanently. Can be filed, sanded and painted. **PLASTIC STEEL** bonds iron, steel, brass, aluminum, wood, concrete, etc., to itself or each other.

LEAKING RADIATOR? — PLASTIC STEEL mends radiators, pipes, tanks and appliances in minutes. No special tools needed. Requires no heat or pressure — will harden under water.

CAR REPAIRS — Save money on auto repairs with **PLASTIC STEEL**. Fix torn fenders, cracked engine blocks, leaking gas tanks.

PLASTIC STEEL has a million uses around the home, garage or farm. 3 convenient home kits — 98c, \$1.89 and \$3.95 **AT LEADING HARDWARE STORES.**

DEVCON CORPORATION

180 ENDICOTT STREET, DANVERS, MASS.

available at last!

HOPPY

SPLIT IMAGE

TRANSIT

*accurate!
inexpensive!
simple!*



ONLY
\$6.95
RETAIL

Amazingly accurate

LEVEL AND

INCLINE MEASURE!

Easy as a camera to operate! One man — ALONE — can do any leveling or incline measuring — down to a fraction of an inch! **A THOUSAND USES!**

Carpentry Leveling
Brick Laying
Foundation Work
Yard Grading
Irrigation
Drainage

Patio & Terracing
Guttering
Masonry
Duct Installation
Contour Plowing
ETC.

**OVER 2 YEARS OF EXHAUSTING RESEARCH!
GUARANTEED PRODUCT SATISFACTION!**

Available at your local Lumber-Hardware store.

Another Quality product by **HOPPY**
HOPKINS MANUFACTURING CORP.
Emporia, Kansas

A Safety Expert Looks at Turnpikes

[Continued from page 87]

the original budget for this purpose, and additional sums are constantly being spent. Many miles of medial guard rails have been covered with a flowering vine and honeysuckle. At Telegraph Hill, near Red Bank, some 5,000 lilies and irises have been planted; the famous Holly Mile near Milepost 17 displays over 100 native holly trees; through one congested area over 7,200 shrubs and vines have been set out.

I have heard hard-boiled highway engineers say that "the motorist doesn't give a hoot what the road looks like so long as it gets him there." This is wrong, and it is high time that planners of future roads learned it. Some roads can capitalize on natural scenic vistas for relief. But when you see Florida's Sunshine State Parkway traversing 108 dreary miles through subtropical country without the hint of a flowering tree or an exotic shrub except around the three restaurants, you see the prosaic highway engineer in his most dour mood.

Even highway signs can do something to provide diversion. The Massachusetts Turnpike has made a beginning by posting names of townships and counties.

6 High-beam glare not intercepted

Considering the inadequate width of most medial strips, headlight glare obviously bothers a large proportion of drivers, even on the six-lane stretches. The upshot is that after dark on busy pikes most drivers habitually maintain daytime speeds on low beam because they get tired of constantly kicking the dimmer switch. Low-beam lighting is bad medicine when you're going at 88 to 103 feet per second. The logical solution is to eliminate the headlight glare so a driver can use his high beam as he should for the posted speed.

For my money, the Garden State Parkway's clever deflector of headlight glare should be mandatory on all expressways. It is a kind of Venetian blind on its side, an open slat fence some four feet high, with the slats running at right angles to the rails. Proper spacing of the slats makes it impossible for any glare from oncoming lights to come through at an

WHY DEPEND ON SOCIAL SECURITY!



ADD TO YOUR INCOME • UP TO \$5.00/HR. SHARPENING ALL TYPES OF LAWN MOWERS

Modern Manufacturing's precision Lawn Mower Sharpener and Bed Knife Grinder makes it easy for you to earn extra cash on a full or part time basis. Many mowers need sharpening. Do it in your basement or garage. Anyone can learn to operate this sharpener. Write today for free brochure. Dept. 11

\$27500
F.O.B. Pasadena

MODERN MFG. CO.

160 N. Fair Oaks Ave.
Pasadena, Calif.

WOOD FINISHING made easy



- seals, primes, finishes.
- dries in 30 minutes
- completely trouble-free

Wherever paints are sold

DEFT 1826 W. 54th St., Los Angeles 62, Calif.

NOW! A SHOPSMITH FOR ONLY \$179.90

Mail postcard today for free catalog on the new SHOPSMITH Mark 2 to: MAGNA POWER TOOL CORP., Dept. 108-S, Menlo Park, California, or Dept. 108-S, Box 2808, Ft. Wayne, Indiana.



DRAINS cellars, cisterns, wash tubs; IRRIGATES - CIRCULATES - SPRAYS

1,001 uses. Stainless shaft. Won't rust or clog! Uses 1/8 HP motor or larger. . . 3/4 HP for up to 3000 GPH; 450 GPH 80' high; or 1800 GPH from 25' well. 1" inlet; 3/4" outlet. Coupling included free. Heavy Duty Ball-Bearing Pump. Up to 7,500 GPH. \$12.95 1 1/4" inlet; 1" outlet.

Postpaid if cash with order. Also other sizes, types. MONEY BACK GUARANTEE.

LABAWCO PUMPS, Belle Mead 3, N. J.

Lowest Price WATER SYSTEM Completely Automatic!

\$49.95 less motor
With 1/8 HP motor, \$69.95
Bronze Gear Pump 275 GPH. 20-40 lbs. 3/4" fittings. Free Circular

CUT ANY SIZE — ANY SHAPE WITH Spearhead Cutter



Handy pocket size — cuts leather, asbestos, rubber, cork, etc. — round 1/4" to 6" — any size straight and odd shapes.

Send Check or Money Order!

935 POSTPAID

ZIMMERMAN PACKING — CINCINNATI 12, OHIO

NEW MAGIC RADIO WALKIE TALKIE!

YOUR OWN POCKET SIZE RADIO STATION!

BROADCASTS TO ANY HOME OR CAR RADIO WITHOUT WIRES OR HOOKUPS! Wt. only 5 oz. Size (1 1/2 x 2 1/2 x 4 1/2"). Built-in telescoping antenna. Powerful Transistor-sensitive microphone, frequency setter, break-in switch! Runs for weeks on self-contained flashlight batteries. Durable plastic case. With this Radio Talkie you CAN TALK TO YOUR FRIENDS UP TO A BLOCK OR MORE AWAY! Talk up to 1 mile or more between two automobiles. INSTANT OPERATION! Just push button to talk! No license needed. Uses inductive field magnetic radiation. Useful and real fun in a million ways! GUARANTEED TO WORK. 1 YEAR SERVICE GUARANTEE. SEND ONLY \$3.00. (cash, ck, mo) and pay postman \$9.99 COD postage or send \$12.99 for pre-paid delivery. COMPLETE READY TO OPERATE with instructions and hundreds of ways and tricks for broadcasts thru any radio you desire. Price may go up soon, so get your NEW POWERFUL RADIO-

WALKIE TALKIE NOW. Available only from: WESTERN RADIO, Dept. RPS-7, KEARNEY, NEBR.

Why LUFKIN CHROME CLAD® lasts so long



Lufkin's exclusive Chrome Clad tape rule blades won't rust, chip or peel.

The bold, black markings are bonded directly to the tempered steel blade. A series of platings is built up over the markings. The final plating is satin chrome, one of the toughest of all metals. This glare-free finish lasts longer . . . resists abrasion and corrosion . . . contrasts sharply with the black markings. You get an easy-to-read blade that can take a terrific amount of wear.

It's Chrome Clad. No finer tape rule was ever made . . . and only Lufkin makes it.

See the new Chrome Clad MezurMatic with gentle "Touch Control" automatic rewind.



THE **LUFKIN** RULE COMPANY
TAPES • RULES • PRECISION TOOLS
SAGINAW, MICH. • MIDDLETOWN, N. Y. • BARRIE, ONT

STOPS PING IN HIGH COMPRESSION ENGINES



Refined from 100% Bradford Pennsylvania Crude Oil, Kendall SuperB All-Weather SAE 10W-30 stops ping and valve lifter clatter . . . reduces engine wear and oil consumption . . . increases engine life and gasoline mileage.

STOPS OUTBOARDS FROM STALLING AT SLOW SPEEDS

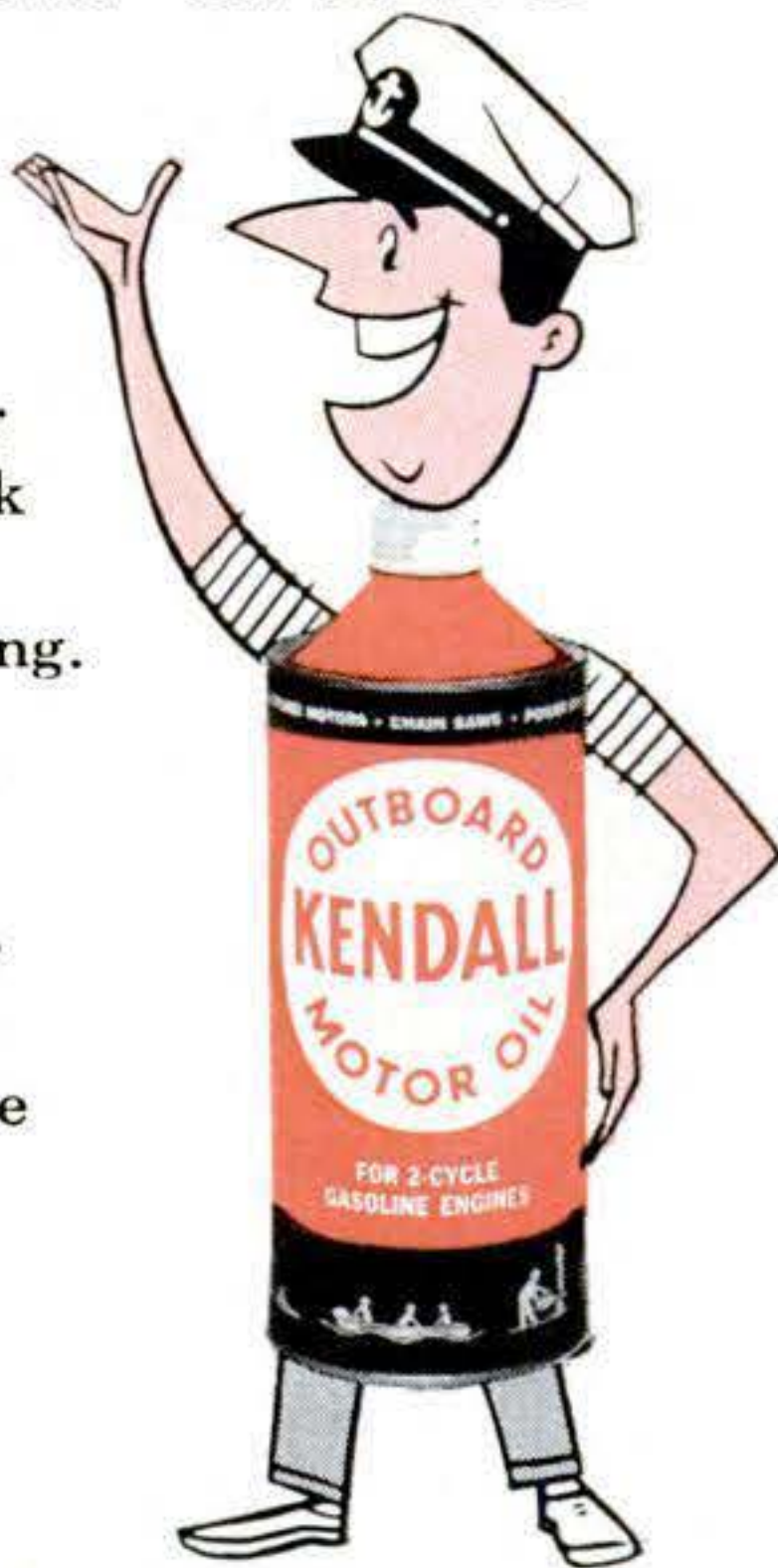

Kendall Outboard Motor Oil reduces spark plug fouling, slow speed stalling. Prevents fuel tank and engine rusting. Spark plugs last longer and so will your engine. Available in 8-ounce and quart cans.

Ask your favorite dealer for it now

KENDALL REFINING COMPANY
BRADFORD, PENNA.

A Safety Expert Looks at Turnpikes

oblique angle, yet you can see through the fence if you turn your head.

Apart from these six specific things, there are other turnpike lessons to be noted. It is reported that there may be no service stations or restaurants on the new interstate network. This would be a grievous blunder. Restaurants are far more than a convenience; they are a safety factor in providing relaxation and refresh-

Sending a Bill?

It'll get there quicker if you use your customer's postal-delivery zone number with his address.

The Post Office has divided 106 cities into postal-delivery zones to speed mail delivery. Be sure to include zone numbers when writing to these cities; be sure to include your zone number in your return address—after the city, before the state.

ment. As for service areas, they are an absolute necessity on a limited-access highway where a motorist may be stranded many miles from help.

Closely related is the need for a saturation of state-police patrols never before dreamed of on state highways. Not only do motorists have breakdowns at remote points—750 a month run out of gas on the short New Jersey Turnpike; 1,100 have flats; 1,800 have mechanical breakdowns—but they are fair game for criminals if policing is sparse. The 131-mile Jersey pike, with an average traffic flow of over 107,000 vehicles a day, has 92 troopers on patrol, or one for each nine miles of highway around the clock. (They have lately added six plainclothes detectives for criminal work, not traffic offenses.) Limited-access pikes are no longer just roads. They are "long, narrow cities" with all the human and physical problems of a municipality with a floating population of some 100 million people a year.

The basic lesson of the turnpikes has been that it is possible to engineer accidents down toward an irreducible minimum. In the process, we change the type and character of the accidents that still occur. And then we cut these in half again with new engineering geared to the new problems.

END

"Summertime and the wheeling is easy"

HARLEY-DAVIDSON

DUO-GLIDE

Here's outdoor fun for all the summers and years to come...with plenty of room for gal or pal. Only the Duo-Glide gives that easy miracle ride — thanks to new swinging-arm rear suspension coupled with Hydra-Glide front fork and spring-loaded seat post.

Cushioned comfort plus 74 cubic inches of dynamic OHV power! First in safety too — new hydraulic rear brake — big surface front brake — stop this streamlined beauty on a dime.

Make a date to test ride the Duo-Glide at your dealer's today. His liberal trade-in deals and the convenient monthly terms make it easy to own a Duo-Glide.



HARLEY-DAVIDSON MOTOR CO.

Dept. PS, Milwaukee 1, Wisconsin

PLANS · PATTERNS · FRAME PACS

World's Largest Selection. Over 200 new plans, Full Size patterns, frame pacs. Designed for the amateur. Prams, racers, cruisers, utilities, inboards, outboards, in wood, plywood, steel. New longitudinal stressed models with revolutionary bulkhead construction. Light, super strong.

Send 35c for 120 pg. PLAN CATALOG

Catalog plus Boat Building Handbook.....\$1.00

SPECIAL OFFER... Plan Catalog ... plus Hardware and Accessories catalog.....\$1.00

CUSTOM-CRAFT · BUFFALO 7M NEW YORK



SPECIAL!

- 120 PAGE PLAN CATALOG PLUS
- 200 PAGE "BOAT BUILDING FOR THE AMATEUR" COVERS
- BOAT BUILDING FIBER-GLASSING
- OUTFITTING, ETC.

Only \$2.50

JEEP OWNERS

RE-POWER NOW with a V-8 engine—Use

FORD · CHEVROLET · MERCURY

in 2 or 4 Whi-Dr. Jeeps, Jeepsters, Sta-Wgn, Trucks, H.J. and Kaiser cars. Conversion Kits \$43.25 to \$59.85. If you want fast action tell us which engine you wish to use, give us year, Model, (2 or 4 Whi-Dr), of your vehicle. Send Min. \$15.00 Dep. and we will ship correct kit, Bal. COD. Send full amt. for Prepaid shipment. Wire, phone or write for free details. (Also kits for Ford 6 engine.)

HOOSIER MACHINE PRODUCTS CO.

314 S.E. 6th St.

Phone CR6-3442

Pendleton, Oregon

STOP FRONT DRIVE DRAG ON YOUR Jeep



OVER 100,000 NOW IN USE!

Warn Hubs on your 4 w. d. give double-duty value—economical, free-wheeling 2 w. d. (with added pep!), normal 4 w. d. —automatically with Lock-O-Matics, manually with Warn Locking Hubs.

See your 4 w. d. dealer!

WARN HUBS

WARN MFG. CO., Inc.

Riverton Box 6064-B7, Seattle 88, Wash.

pull the trigger...

spray paint

7 times faster than brushing!



Speedy Sprayer

ONLY \$32.00
less motor

Paints anything from a house to a toy. Saves its cost on the first major job! Speedy Sprayer does in minutes what brushing takes hours. Finish is smooth, flawless. Uses any 1/4 h.p. motor with 1/2" shaft. No. 780 Outfit—10 ft. air hose, tire chuck, quart gun, less motor, only \$32.00. Every workshop should have it. At leading stores.

Free! Write for "How To Spray" Booklet and folder.

W. R. BROWN CORPORATION

Specialists in Portable Paint Sprayers for Over 37 Years
2637 N. NORMANDY AVENUE, CHICAGO 35, ILL.

For a tight grip
in tight places...

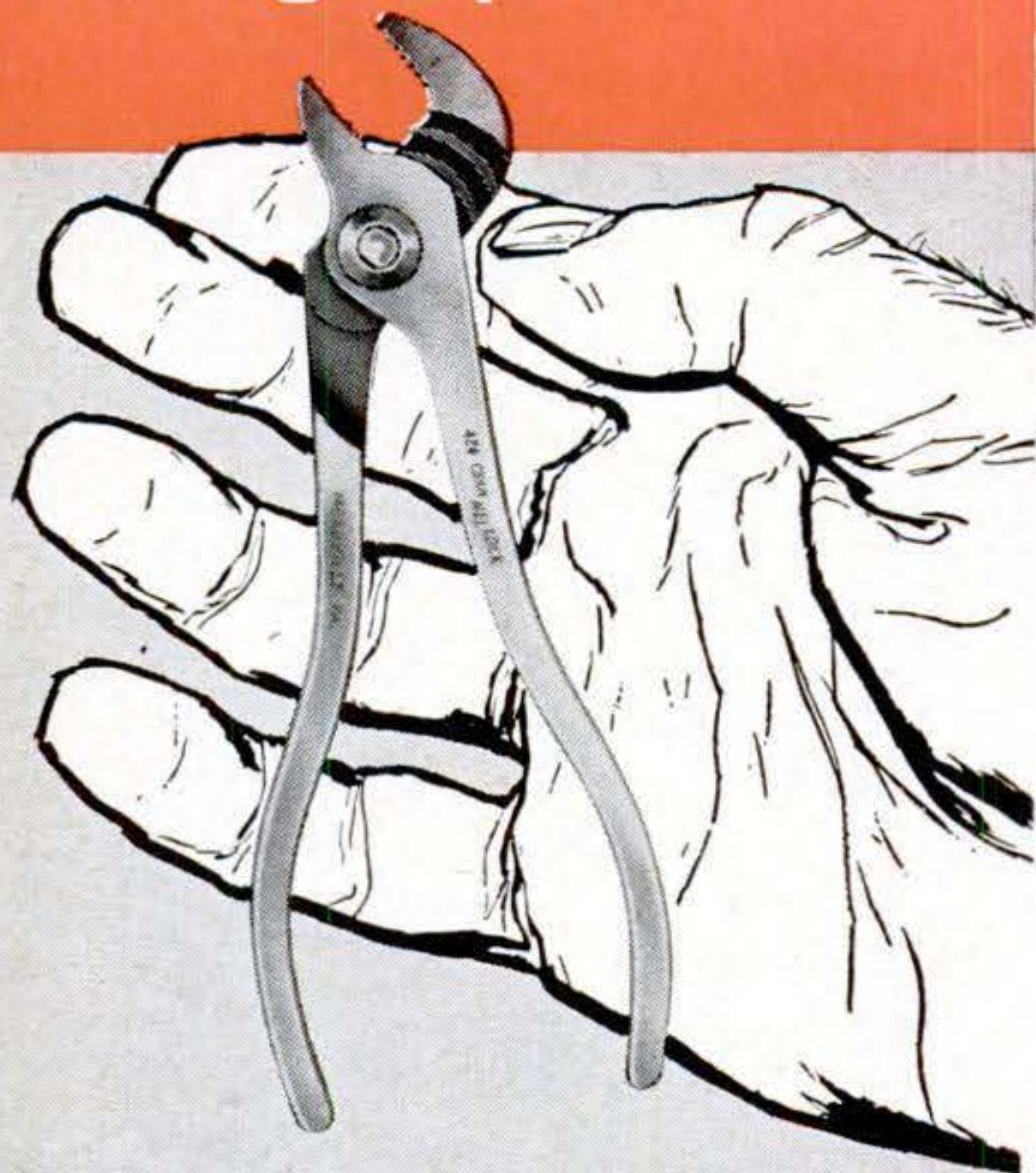

The "Mighty Midget"

CHAN NEL LOCK®

No. 424

This "mighty midget" is a natural for a tight grip on small work in hard-to-get-at places. Only 4-1/2" long... drop forged from high grade steel. Four exclusive Channellock precision grooved jaw adjustments... capacity to 1/2". Skilled mechanics say it's one of the handiest pliers in their kits. You'll say so, too!

CHAMPION DeARMENT TOOL COMPANY • MEADVILLE, PA.

ASK YOUR TOOL SUPPLIER
FOR A CHANNELLOCK No. 424

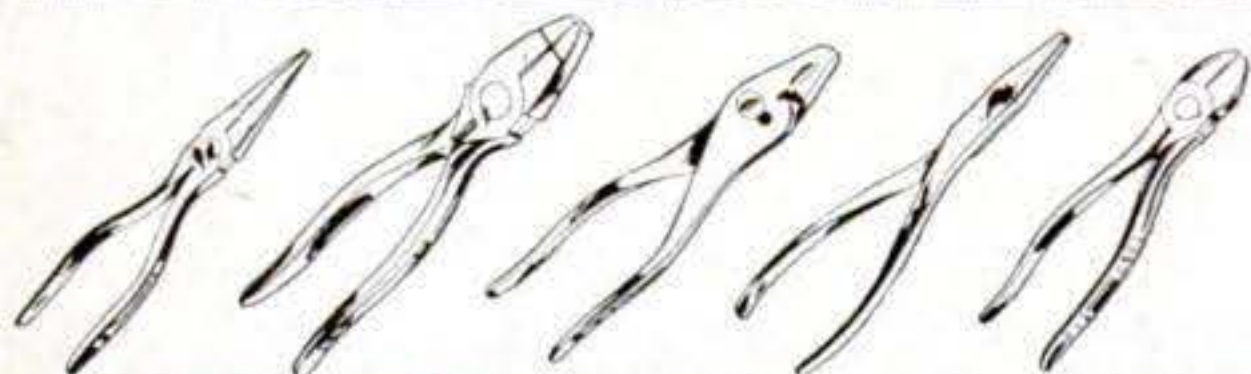

Be sure it's a genuine CHANNELLOCK
Look for the trademark on the handle

World's Biggest Sub

[Continued from page 91]

actor. If the reactor speeds up and gets hot, it can 'run away.' So we've built a high-speed emergency cooling system. It can be triggered instantly if Triton is hit."

A safety injection system, I was told, prevents the products of fission from getting into the habitable parts of the sub if the fuel starts to disintegrate.

Engines can be repaired while Triton is underway. The steam from the heat of each reactor can be sent to either turbine—another "first"—and the single reactor can shoot the sub along the surface or undersea at 75 percent of her normal top speed.

Meanwhile the damaged reactor can be shut down and crewmen can clamber in to repair it. Inside, as in all other parts of the submarine, plenty of elbow room has been left so the crew can work efficiently. Big eyes and trolley tracks to support hoists have been built into overhead beams where needed.

The ship's service generator, often inaccessible on subs, is easy to get to. Electronic equipment can be rolled away from the bulkhead on tracks so technicians can get in behind to repair it.

TRITON'S lines are not as sleek as the Albacore's. Her bow is more like a destroyer's, and for good reason. She is designed to make as much speed on the surface as she does underwater. That means that she's more stable than Albacore on the surface, for she can take the pounding of rough weather at high speed without rolling excessively, then quickly drop to her floor where she can continue at the same speed.

The sail is not sleek. It is big and round to house the many complex, hydraulically retractable radar antennas that will sweep the horizon in search of enemy aircraft and ships.

With her fantastic maneuverability, her tremendous range, and her high reliability, Triton may well be the forerunner of our underwater fleet of tomorrow. END

Next Month: How do lightning rods work? When doesn't a house need any? How do you check installation? Knowing the right answers could save you lives and dollars. Read: "Why Lightning Rods Are a Good Thing" . . . in August PS.

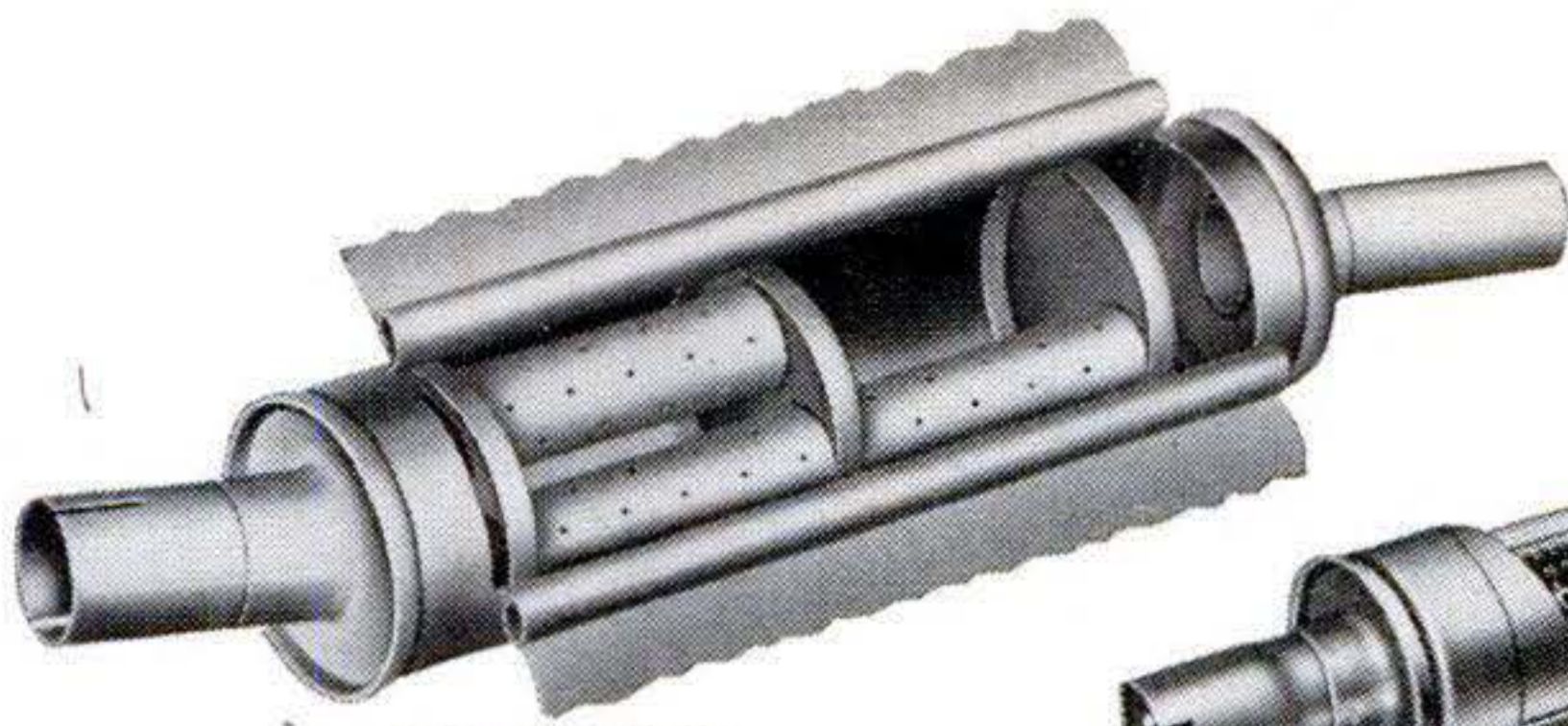

ENGINEERED

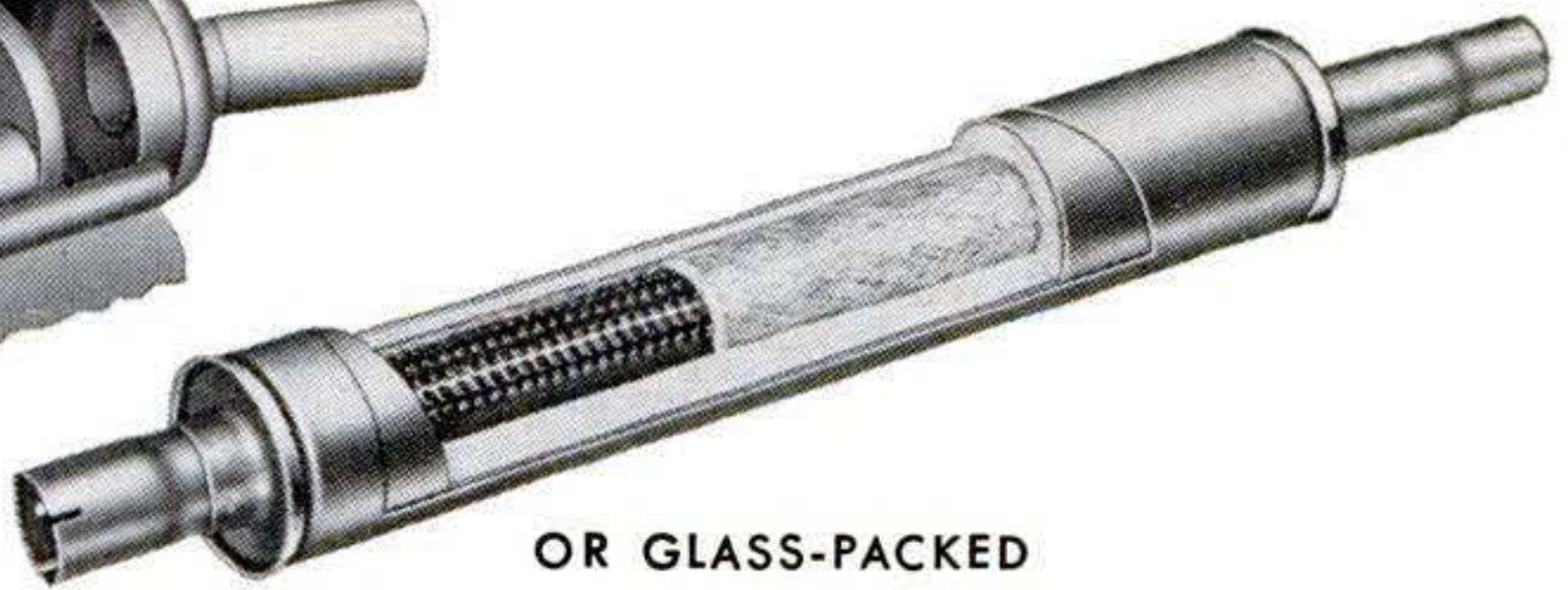

OR GLASS-PACKED

For that unique sound of POWER

DYNATONE NOW OFFERS YOU TWO GREAT MUFFLERS

.....

No muffler can give your car the special sound of a Dynatone. And *now* you can choose from *two* sensational Dynatone styles. Each has its own distinctive voice. Choose the deep, mellow sound of the engineered Dynatone. Or you may prefer the smooth, off-key purr of the new Dynatone Glass-Packed. It features straight-through design with a big 2-in. inner pipe for power and two kinds of glass packing to trap high frequencies and let through only the power tones.

Take your pick. Both cut power-stealing back pressure to a minimum. Both give you finer performance, better operating economy, and the thousands of miles of *extra* service you always get with Dynatone.

AT YOUR FAVORITE DEALER OR
AUTOMOTIVE STORE

DYNATONE®

Dept. 4G, Toledo 1, Ohio

PUMP WATER FAST!
DRAIN WASH TUBS, CELLARS, CISTERNS
IRRIGATE—FILL TANKS—DRAW WELL WATER

#7 Pump—360 GPH, 1750 RPM, 3/4" Inlet, 1/2" outlet, \$7.95 ppd. #8 Pump—1200 GPH, 1750 RPM, 1 1/4" Inlet, 1" Outlet, \$11.95 ppd. #9 Pump—3600 GPH, 1750 RPM, 1 1/2" Inlet, 1 1/2" outlet, \$14.95 ppd. All pumps threaded for pipe—Open impeller will not clog. Ironclad Guarantee. Send check or M.O. or send COD.

Free Pump Catalog
MOORE PUMP COMPANY
SWEDSBORO 1, N. J.

NEW - MIDGET SHORT WAVE RADIO

WORLD WIDE RADIO—Anytime—Anywhere!
Hear England, France, Germany, Spain, Italy, Russia, Africa, Australia, South America—ANYWHERE IN THE WORLD. ANYWHERE YOU GO! Gets ALL foreign radio stations. Not much larger than a postcard—only 4 1/2 x 4 1/2 x 6". Wt. only 3 lbs! Complete with roll out antenna and standard low cost flashlight batteries—NO A.C. PLUG-INS NEEDED EVER! Gets American broadcasts—550 kc to 42 megacycles—continuous on 6-1 ratio tuning dial. Radio Amateur bands 160-80-40-20-15-10. Ships, Aircraft, Air Force, 2-way Mobile, Police—Citizens Bands! THERE IS NOTHING LIKE THIS MIDGET ALL-WAVE RADIO ANYWHERE ELSE AT ANY PRICE! Wonderful for tourists, Boy Scouts, Radio Amateurs—ANYONE! YOU CAN HEAR THE WHOLE WORLD DAY OR NIGHT—EVEN "SPUTNIKS."

SEND ONLY \$5.00 (bill, ck, mo) and pay postman \$12.95 COD postage on arrival or send \$16.95 for postpaid delivery. Complete easy to wire kit includes all parts, tubes, broadcast coil, plastoid cabinet, instructions, (set of long life batteries \$3.49 extra). COMPLETELY WIRED AND TESTED POSTPAID IN USA ONLY \$21.95! Easily worth \$49.95 or more. Order now for WORLD-WIDE listening pleasure. AVAILABLE ONLY FROM:
WESTERN RADIO Dept. BRS-7 KEARNEY, NEBRASKA

BUILD YOUR OWN AIR CONDITIONERS

From Junked Refrigerators for a Few Dollars
INSTRUCTION BOOKS SHOW YOU HOW. 75c EACH

Special Offer
2 Bks—\$1.00
3 Bks—\$1.50
or all 5 for \$2.00

FREE!
Instructions and Literature on kits.

Complete "Install-It-Yourself" Air Conditioner kits for home and automobile, 2 Ton capacity. Brand New Parts—\$119.00 and up.
Kool Engineering Co., Dept. F-7, 1318 N. Clyburn, Chicago 10, Ill.

WORLD'S MOST EXPERIENCED VACATION GUIDE HULL AUTO COMPASS

For 25 years, the famous, accurate Hull Auto Compass has guided millions to their choice of vacation lands. \$5.50 to \$7.95. In colors or bright silver.

AT YOUR DEALER'S OR BEST BOAT COMPASS
WRITE FOR LITERATURE TO GO BUY, TOO

HULL MFG. CO. P.O. Box 246-E-7, Warren, Ohio

BIG Profits in arc welding!
earn extra money with these low cost welders

One of these low cost Hobart Arc Welders will immediately set you up in a highly profitable business—enabling you to capitalize on the ever expanding demand for emergency repair and construction jobs. Hobart welders give high efficiency at low cost—let you weld right on the spot—saving costly tear-down and assembly. Write for complete details—no obligation.

HOBART BROS. CO., Box P-78, Troy, Ohio, phone FE 2-1223



More cutting power
for 1/4" electric drills

Irwin Speedbor "88"
most revolutionary bit in years

Irwin's Exclusive Hollow Ground Point and spade-type cutters bore faster, deeper, cleaner with less power. Try the Speedbor "88" in your small 1/4" electric drill or drill press and see. Get smooth, effortless cutting action in hard or soft woods, plaster, plywood, plastics — even hardrock maple! Forged in one piece from solid bar of high carbon steel, hardened full length to stay sharp. And remember . . . the hollow ground point is exclusive with Irwin's Speedbor "88". Buy individual sizes or sets from your independent hardware dealer.

No. 886-R plastic roll set of 6, sizes 3/8" to 1", only \$4.50



75¢
each
1/4" to 1"
\$1.25
each
1 1/8" to 1 1/2"

IRWIN
Wilmington, Ohio

- the original solid center auger bit
- screw drivers • screw driver bits

BUILD THIS DREAM SWIMMING POOL

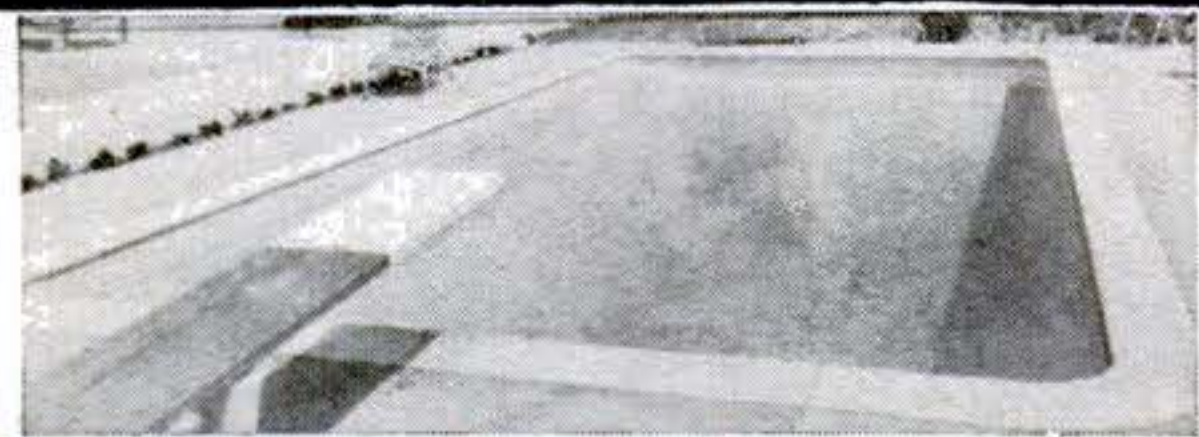

Actual Size
15x30

IN TWO WEEKS
For Only \$500⁰⁰!

Its easy . . . you can build a concrete gunnite, dry pack or concrete block pool with our professionally proven step by step instruction book "So you want to build a Pool." The only book of its kind ever written. Book contains over 200 pages of factual text; 160 illustrations and photos of construction details, outlining in easy to do steps the planning, layout, excavation and building of your dream pool. How to install the deck, coping and tiling. Nothing is left out. This book will save you many hundreds of dollars. Worth many times the price.



Send for free bargain catalog of pool accessories

ONLY \$3.00
postpaid
10 day trial

FRANK A. REED PRODUCTS
1009 N. RAYMOND, PASADENA 3, CALIFORNIA PS-1

- Enclosed find \$3 for one copy of "So You Want to Build a Pool" with ten day return privilege and full refund.
- Send COD, same return privilege. Calif. residents add 4% Sales Tax.
- Send me free catalog of pool accessories.

Name _____
Address _____
City _____ Zone _____ State _____

Buyer's Guide to Window Fans

[Continued from page 138]

Most experts also agree that there is little value in the idea that one twin can pull air in while the other blows it out. To work properly, a fan must exhaust air from the entire room so it can be replaced by fresh air flowing in through other windows. Two fans working at cross-purposes in the same window simply transfer air from one fan to the other without circulating it through the room.

In general, it's best to use twins only where a single larger fan won't fit.

How to see through the glitter. You'll be intrigued with such advanced convenience features as automatic thermostats, three-speed switches, air purifiers, electrically reversible motors, dust and pollen filters, indicator lights, rollaway stands, diffuser grilles, and certainly the high-fashion styling.

But to be sure of getting efficient, trouble-free service the first things to look for are:

- Sturdy construction
- Ample motor power
- Good mechanical balance
- Quiet operation

Construction: Inspect the motor mount closely to see if it is sufficiently rigid to carry the fan motor without vibrating. A tinny metal frame will rattle when you get it home even if it won't in the store.

Motor: Most makers rate their motors on input watts—from 100 to 200 watts for a 20" fan—or in fractional horsepower, usually about 1/15 hp. While these are only rough guides to motor power, they may help in spotting any that are way out of line with the average.

Mechanical balance: Bad blade balance and alignment are frequent causes of fan noise. In manufacture, blades are precisely matched by weight in sets before being fused to the metal hub. Even then, the assembly must be checked and weights added where necessary for true balance. Test the fan before you buy to detect undue noise, vibration or rattle.

It is possible to step up the air-moving capacity of a fan by giving the blades greater pitch, but if the motor is not designed for that duty it will labor noisily and may even burn out prematurely. You can check this by letting the fan run and making a noise comparison. The right blade pitch is one that gives greatest ef-

ALL NEW

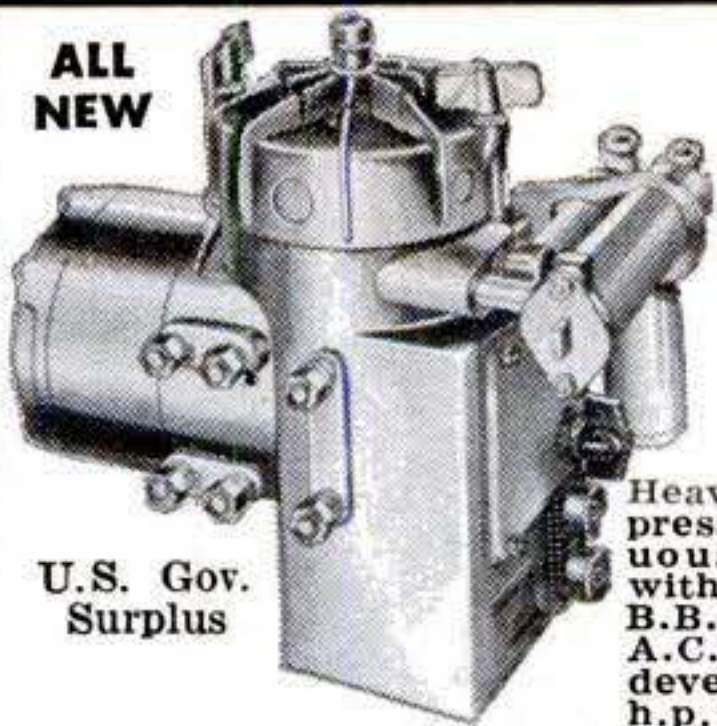

U.S. Gov. Surplus

PAINT SPRAY UNIT

Including Spray Gun

APPROX. ORIGINAL COST \$325

OUR LOW PRICE \$34.50

FOB Chicago

Heavy duty compressor for continuous operation with G.E. or equal B.B. Motor, 110 V., A.C., rated 1/8 h.p., develops over 1/4 h.p. 1-Quart Pressure

type gun with round, fan and ceiling spray nozzles. Line filter, air drier, air gauge, 20 ft. cord & plug, 20 ft. air hose. Sprays paint, lacquer, enamel, insecticides, etc. Paints house, auto. ANYTHING. Instructions furnished. NOTHING ELSE TO BUY. Wt. 65 lbs. Tire chuck for inflating tires, 75c extra.

ORDER FROM THIS AD. Money Back Guarantee.

Send check or money order.

ILLINOIS MFG. & SUPPLY CO.

1829 S. State Street Dept. PS 7, Chicago 16, Ill.



stops vapor lock!

— helps give instant starts all year long!

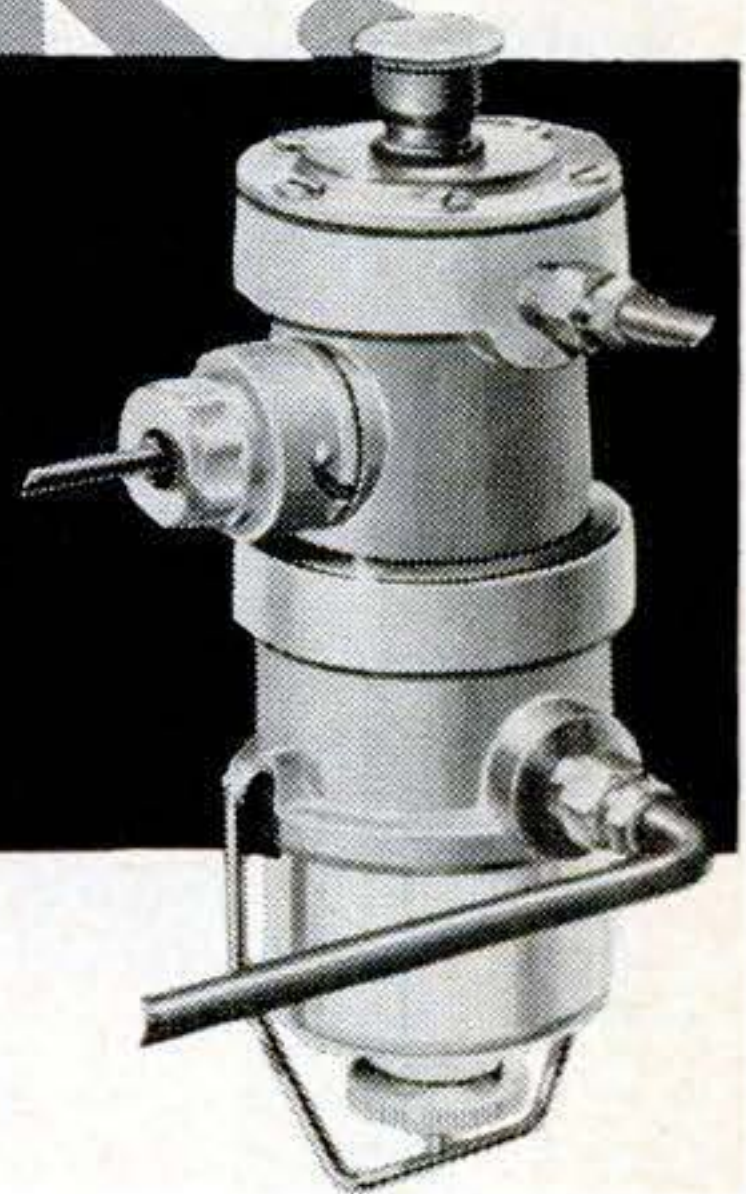

NEW...

STEWART-WARNER electric fuel pump

- ▶ For cars, trucks and all gasoline engines!
- ▶ Operates independently of engine to assure positive flow of gas—always.
- ▶ Built-in fuel filter. Extra-large reservoir and oversize piston, coil and power spring.
- ▶ Built-in automatic pressure regulator. Prevents flooding and starving. Gives smooth, steady fuel supply . . . eliminates surging.
- ▶ Pump may be mounted under hood, on fire wall or fender panel, or on frame near gas tank.

Ask for it at your car dealer, service station, garage or automotive parts store.

OR WRITE TO:



INSTRUMENT DIVISION
STEWART-WARNER
CORPORATION

Dept. AN-78, 1840 Diversey Parkway, Chicago 14, Ill.

JULY 1958 205

NEW! FOR FINISHING WOOD EDGES



WELDWOOD FLEXIBLE WOOD TRIM

Real wood veneer, paper-backed, in handy rolls, for edging plywood, lumber. Many decorative uses. Apply with Contact Cement, or Presto-Set Glue. Oak, birch, African mahogany, walnut, fir, Sonora.® At your lumber dealer's.

SAVE! Get 89¢ sample roll, 8' x 1", specify wood. Send this ad with 50¢ to: United States Plywood Corp., Dept. PS-7-58 55 W. 44th St., N. Y. 36, N. Y.

1 You can turn one tool into twenty-four with **Black & Decker** **MAGIC SWITCH ATTACHMENTS** **24**

3 CU. FT. MIXER \$49.50

DIRECT FROM MFG.

Saves 3/4 cost of ready mixed concrete. Pays for itself on first job.

3 Cu. Ft. Drum—
Mixes 2 Cu. Ft. Concrete \$49.50

5 Cu. Ft. Drum—
Mixes 3 Cu. Ft. Concrete 69.50

Motor and wheels extra. FOB Pulaski, N.Y.

Cash, Check or M.O. Money back guarantee.

UNITED STATES FORGE AND FOUNDRY CO.

Construction Equipment Div. Pulaski, New York



WAR SURPLUS ELECTRIC WELDERS \$19.50

Aircraft P.1 generator, 24-volt, 200 amps. makes ideal welder, only \$19.50. R.1 generator, 300 amps., 24-volt, only \$23.50. Rheostat for above generators, \$3.98. Hydraulic cylinder, double acting, 1 1/8" shaft, 3" bore, 11" stroke, 8,000 lift capacity, only \$15.95, many other sizes hydraulic cylinders. Vickers hydraulic pump, 1,000 P.S.I., special \$16.95. Hydraulic control valves, \$14.95. B-29 pump, pumps 400 gallon per hour only \$9.95. Aircraft starters, makes good winch only \$9.95. Hundreds of other government surplus items. Order by mail today, immediate delivery. Send check or money order, satisfaction guaranteed.

AIRPLANE SURPLUS COMPANY

3055 NORTH BROADWAY

WICHITA, KANSAS

Works in seconds!



Loosens Rusted Bolts nuts, screws, "frozen" parts!

LIQUID WRENCH®

The super-penetrating rust solvent that quickly loosens rust and corrosion.

AT HARDWARE STORES, GARAGES SERVICE STATIONS, EVERYWHERE

RADIATOR SPECIALTY CO.
Charlotte, N. C.

3 oz. CAN 35c

**NEW! Evans
POWER-TAPE**

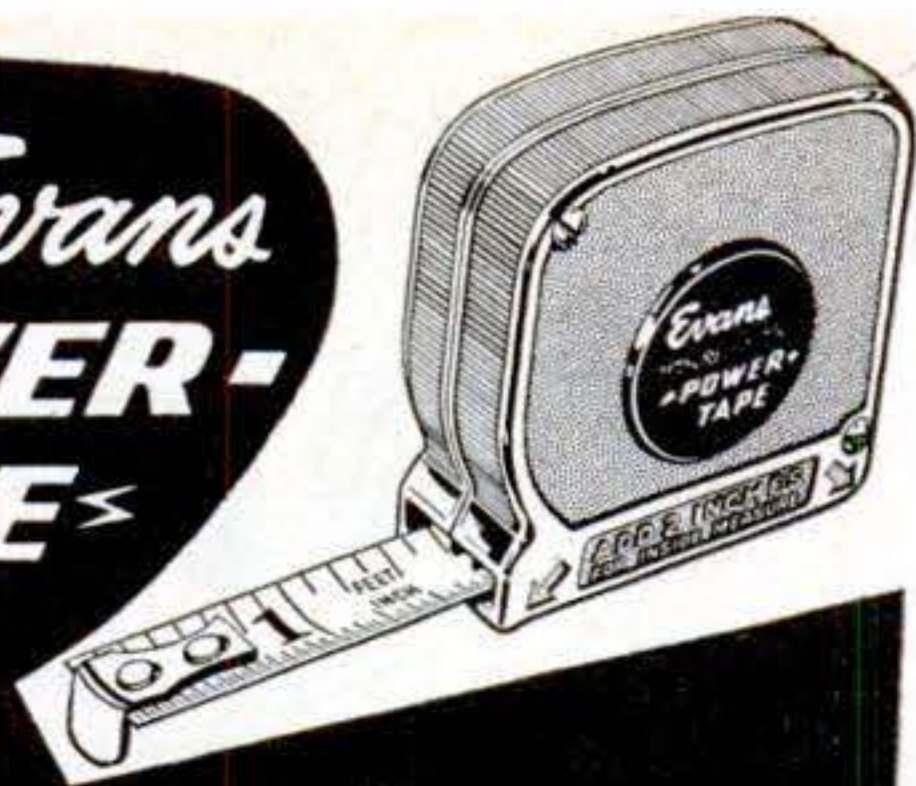

**No More Pushing Blade
Back Into Case!**

Here's the greatest single mechanical advance in steel tape history! Press the button gently with your thumb — blade returns smoothly. You control the speed. Release the button—blade stops instantly. No "creep," no lost measurements! Chrome-plated case, GIANT sliding end hook — for inside-outside measuring. White steel blade, marked in inches and feet-and-inches—no figuring! Free Tenite carrying case with magnifying lens.

Only
\$1.89
(10 ft.)

Unconditionally Guaranteed
6, 8, 10, or 12 ft. lengths
Get POWER-TAPE today!

Available only at hardware stores

Evans RULE CO. Elizabeth, N. J.
Montreal, Que.

**In Summer
IS YOUR HOUSE**

"FRY-PAN HOT"?

Make it **COMFORT-COOL**

with the miracle insulation
used in cold storage plants!



Insulate Now with ZONOLITE

Do-it-Yourself IN HALF-a-DAY! Easiest of all insulations to install. Just pour it, level it, leave it! Guaranteed for life of the building.



You're cool by day, you sleep at night, when you fill between attic joists with Zonolite vermiculite insulation! Summer sizzle comes indoors through the roof, but heat bounces off and you are as much as 15° cooler indoors when you have Zonolite in the attic. Zonolite, same insulation used in cold storage plants, beats withering summer heat in your house—will save up to 40% on fuel each winter, too! Costs as little as \$67.60 for average attic!

Mail Coupon for FREE INSULATION BOOKLET

ZONOLITE COMPANY Dept. PS-78
135 S. La Salle St., Chicago 3, Ill.

Send me folder HI-47 on Zonolite insulation.

Name _____

Address _____

City _____ Zone _____ State _____

GET ESTIMATE AT LUMBER AND BUILDING SUPPLY DEALERS

Buyer's Guide to Window Fans

efficiency with the motor at the lowest noise level.

The "extras." After you've decided on a specific make, you'll face the question of special features. You can get a 20" standard-make fan, such as a GE, for \$29.95, \$34.95, \$44.95, \$59.95, or \$69.95. All have closely equivalent blades, motors and housing. The differences will be in the styling and convenience features.

A reversing switch makes it easy to change the rotation of the blades so they pull air in instead of blowing it out. This may be necessary in rooms with no second window to let in fresh air. In this case, it's best to exhaust some hot air first, then quickly reverse the fan to draw in cool outside air.

A reversing switch adds about \$10 to the price of a fan. Without one, most fans can be reversed by turning them around in the window, but this takes a little time.

A built-in thermostat adds about another \$10 and does have some drawbacks. It cannot be as closely controlled as a furnace thermostat and does not respond entirely to true inside temperature since it is affected by the air passing through it at the window. But it does help prevent overchilling at night by shutting off the fan before the temperature drops too low.

You may prefer a timer, at lower cost, which can be set to turn off the fan after you've gone to sleep.

Portability. There will be occasions for using a fan other than for exhaust. During the day, when the sun is strong, it's best to keep all windows closed and shaded, so hot outside air is sealed out. The fan may then be used to circulate and freshen the air.

For this reason, many fans have carrying handles or can be placed on wheeled stands to make them easily portable. Some fans, however, are strictly for use in windows and are not adaptable for other purposes, as the side window panels are part of the motor housing.

Speed-selector switches let you run your fan at two or three different speeds to vary the volume of air it delivers. This way, you can set it at the lowest speed that will provide the cooling capacity you need and keep noise to a minimum. In a bedroom at night, this may be well worth the few extra bucks that such a switch costs.

END

BRITISH ENFIELD RIFLE & SOFTNOSE AMMO

\$5.00

DEPOSIT!
HUNTING SEASON SPECIAL ADVANCE SALE!



The perfect hunting rifle, fast, super accurate, smooth 10-shot bolt action. Hot .303 Caliber ammo made by all major U.S. firms. This is famous No. 1 Mk. 3 Enfield .303 Cal. with superb hardwood stock. Bores are beautiful. Weighs just 8½ lbs. Each gun has British proof-house and Royal ordnance marks. A fabulous buy. SAVE ON AMMO: .303 target, 100 rds. \$7.50. Softnose hunting ammo, 40 rds., \$5.90. .303 ENFIELD RIFLE as described just \$13.95. FREE TRIAL ORDER: Send \$5 deposit, balance C.O.D. Shipped F.O.B. Los Angeles. Test fire, return in 10 days for full refund if not perfect in every way. Calif. resid. add 4% state tax.

THE ELLNER COMPANY

Dept. 26,
1206 Maple Avenue
Los Angeles 15, Calif.

KING MIDGET

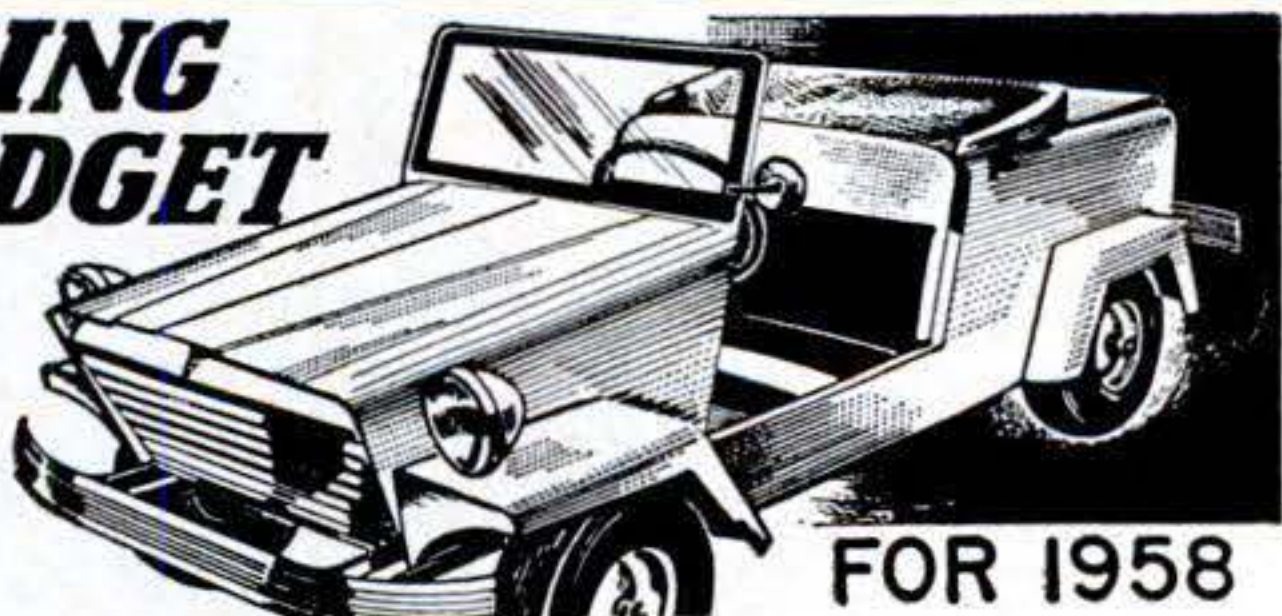

FOR 1958

More power, beautiful styling. New Features. Still World's Lowest Priced Car. Drive it for 75c a week. Rider agents wanted. Earn your own car. If no dealer near you send 25c for 32 page picture book with full details and dealer price. Or send \$1 (refunded first order) for this and Service Manual, plus Repair Manual, plus 15 5x7 photos of car and factory.

MIDGET MOTORS CORPORATION, Athens 2, Ohio

2 WAY PORTABLE RADIO SET

SENDS—RECEIVES UP TO 10 MILES AS SHOWN with built-in antenna or hundreds of miles with outside antenna Works on 80 and 40 meter (Novice) amateur radio-bands—also Aircraft and overseas broadcast (3 to 8 mc). PORTABLE SELF-CONTAINED POWERED WITH STANDARD PORTABLE RADIO BATTERIES. NO AC PLUGS NEEDED! Take it with you everywhere you go—on trips, vacations, camping—Keep in contact with home, friends. Has 5 watt crystal controlled transmitter—Sensitive Regenerative Receiver. Send-Receive switch. Wt. only 3 lbs. Size, only 6"x4"x4". TESTED—PROVEN—SIMPLIFIED—PRACTICAL—Full information given on quick easy way to get license.



WESTERN RADIO

SEND ONLY \$3 (bill, ck, mo) and pay postman \$12.95 COD postage on arrival or send \$15.95 for postpaid delivery. Complete kit includes all parts, tube, coils plastoid cabinet, easy instructions. (Set of batteries \$3.49; crystal \$1.49.) COMPLETELY WIRED AND TESTED. POSTPAID \$19.95. A regular \$49.95 value—Order now before price goes up. GUARANTEED—AVAILABLE ONLY FROM:
DEPT. BNS-7 KEARNEY, NEBR.

ENGINES "Sing"!

WITH **MILESMASTER**®

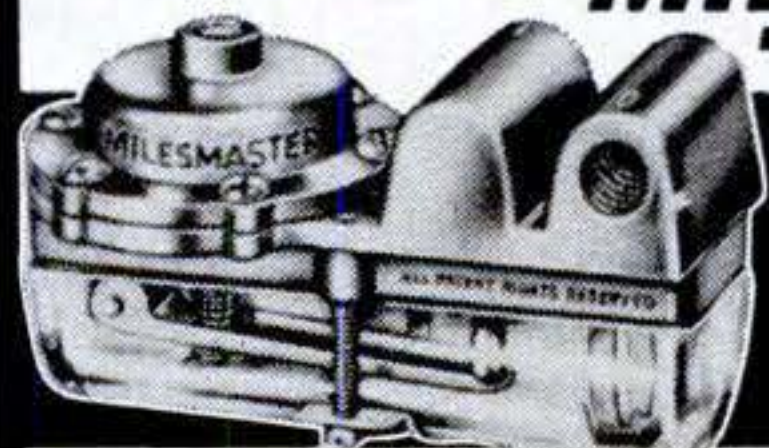

FUEL PRESSURE REGULATOR

For smooth running, quick starting, better mileage . . . install a genuine MILESMASTER. Prevents flooding. Only \$6.95

MILESMASTER, INC., Dept. J, Exeland, Wisconsin

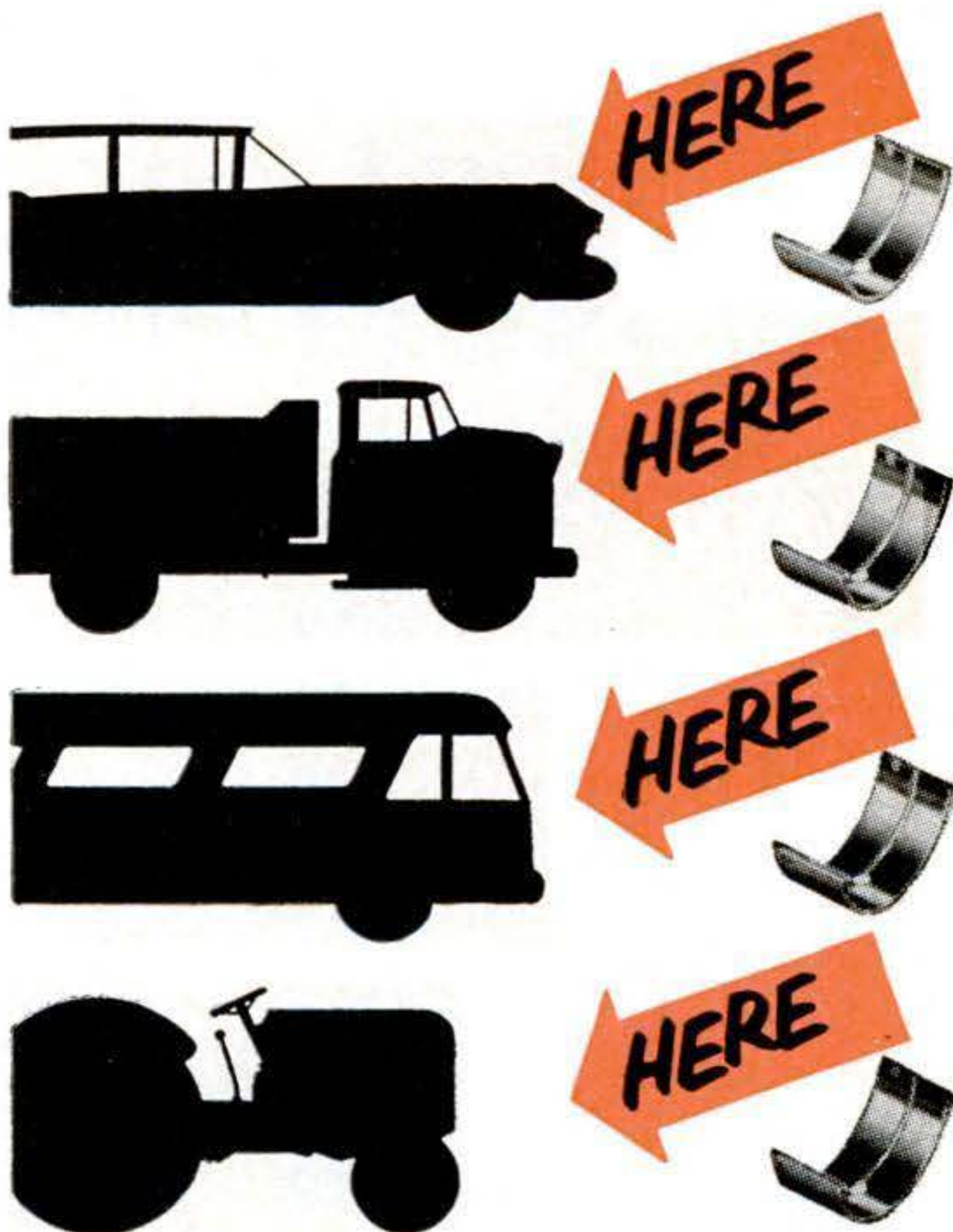

In engine reconditioning

FEDERAL-MOGUL means FINE PERFORMANCE!

Any engine will perform better when reconditioning includes Federal-Mogul bearings. They are *engineered* for the job. If the crankshaft has to be turned down, there are Federal-Mogul bearings in the correct under-size to fit it. Federal-Mogul reborable bearings can be align bored. For heavy-duty jobs, Federal-Mogul sintered copper-alloys are the answer. That's why mechanics **PREFER** Federal-Mogul bearings . . . they are designed to restore fine performance. Ask *your* mechanic!



FEDERAL-MOGUL SERVICE
Division of Federal-Mogul-Bower Bearings, Inc.



Popular Science test records No. 1 and No. 2 only...

A pair of Hi Fi tools that no Hi Fi fan can afford to be without! Developed, recorded, and produced by electronics engineers and by the Editors of Popular Science Monthly as another service to their readers.



TESTING VOL. 2

- PROVES YOUR SYSTEM'S TRUE HIGH-FIDELITY
- TRUE MUSICAL TONE OF 12 INSTRUMENTS
- COMPARISON TEST OF TRUE SYSTEM PERFORMANCE
- CHECKS SYSTEM WITH MUSIC—THE ONLY ACCURATE TEST
- UNIQUE A-B METHOD SPOTS LOWEST AND HIGHEST TONES
- DISTINGUISHES BETWEEN TRUE AND ARTIFICIAL BASS
- AIDS IN BALANCING SPEAKER SYSTEMS
- HELPS DETERMINE PICK-UP, AMPLIFIER OR SPEAKER FAULT
- SPOTS "AGEING" DEFECTS BEFORE THEY GET SERIOUS
- ENHANCES MUSICAL APPRECIATION USING MUSICAL INSTRUMENTS
- DISTORTION TEST
- MUSICAL QUIZ

(33 $\frac{1}{3}$ L.P.)

\$3.50

List Price \$3.98 each

each
\$6 for
a pair



You may want two!
Two No. 1 records or
two No. 2 records cost you
only \$1.50 for the extra record!

Stop disappointment when you buy new equipment. Get the best out of your present rig. By playing the P.S. Test Records and listening to the sound from your loudspeaker, you can pinpoint faults that mar your listening pleasure. Detailed instructions with each record guide you through various tests—tell you what to listen for and what each sound means in terms of the performance of each component.

Each record serves its own particular purpose. They work as a team to give a hi fi system the most thorough workout available to the layman. No fault can hide from the revealing tests you can make yourself with these two records.

Test Record No. 1, "Testing With Sine Wave Frequencies," uses electronically produced tones to analyze each component in your hi fi set. Here are just a few of its features:

- Band of pure sine wave sweep frequency—continuous from 20,000 to 20 cycles. Plus a continuous sweep from 300 to 20 cycles, with frequency markers every 50 cycles—ideal for tuning bass-reflex and other speaker enclosures.
- Turntable rumble test with 1000-cycle reference signal recorded at precisely 7 cm/sec adjacent to one minute of silent grooves.
- Stylus test with a signal recorded at extreme outer groove for comparison with the same signal recorded at innermost groove—a revealing test for stylus wear or pickup-cartridge deficiencies.

Test Record No. 2, "The True Sounds Of Musical Tones," consists entirely of life-like tones of the actual instruments of a symphony orchestra—employed in a unique way to let you hear how your set gives out with real music.

- Explores the personality of orchestral instruments—different instruments, played solo and in orchestra, demonstrate their distinctive sounds.
- Tests bass response with actual music—musical instruments measure the useful low-end response with a special technique.
- Shows how high frequencies give realism to music—calibrated filters check the upper limits of your hi-fi.

MAIL THIS COUPON TODAY!

Magazine Services, Inc., Department R758
104 East 26th Street, New York 10, New York

Please send me, postage free, and fully guaranteed, the number of Popular Science Hi-Fi Test Records I have checked below. My check or money order is enclosed.

- | | |
|---|--------------------------------------|
| <input type="checkbox"/> \$3.50 for one Test Record No. 1
(Testing With Sine Wave Frequencies) | <input type="checkbox"/> \$5 for two |
| <input type="checkbox"/> \$3.50 for one Test Record No. 2
(True Sounds of Musical Tones) | <input type="checkbox"/> \$5 for two |
| <input type="checkbox"/> \$6 for one Test Record No. 1 and one No. 2 | |

Name _____

Address _____

City _____ State _____

Nationally distributed by Urania Records, 625 Eighth Ave., New York, N. Y.



Makes Rooms Cheerful!

Your reward when you install Danbury Rubber Tile is a lastingly cheerful floor — comfortable to walk on, easy to keep lustrously bright.

FREE! Write for the Danbury Floor Pattern Planner and Installation Guide.

THE DANBURY RUBBER COMPANY, INC.
Flooring Division—Danbury, Connecticut

Find Any Little Item . . . In Seconds!

JIFFY UTILITY CABINETS

Stop losing or misplacing small items . . . keep them ever handy, visible, clean and safe in Jiffy Cabinets. Serves as handy storage for small things in kitchen, workshop, office, den, garage, sewing or hobby room. Drawers 5 $\frac{3}{4}$ " x 2 $\frac{1}{4}$ " x 1 $\frac{1}{4}$ " are made of crystal clear styrene plastic with deep-in dividers to make 3 compartments plus index labels to fit slots in drawer fronts. Stopper back permits drawer to hang open without spilling. Dust-proof, partitioned, welded solid metal frame, rubber feet, frame punched for easy hanging.

16 Drawer Unit . . . \$6.00 ppd.
24 Drawer Unit . . . 8.00 ppd.
32 Drawer Unit . . . 11.00 ppd.
48 Drawer Unit . . . 15.75 ppd.

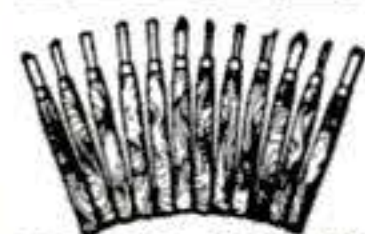

Surgical Steel Hand Ground Set of 12

\$2.00 CARVING KNIVES

ppd. The sharpest, keenest ground, surgical steel blades we have ever seen—sharp enough to split a human hair in two! 12 different shapes and edges can do every job of wood carving, model making, linoleum cutting, sculpting and whittling imaginable. Each blade has a 4 $\frac{1}{2}$ " long hardwood handle for easy gripping. Heavy duty blade is firmly attached by means of a brass ferrule to insure long, continued rugged use. Each surgical steel blade precision hand ground to easily and quickly notch and cut any shape you wish. A sensational all-purpose set, well worth \$5.95.

OUR PRICE \$2.00 ppd.

One of our BEST Values!



2.9 Amp. Heavy Duty $\frac{1}{4}$ " RAM DRILL

with Jacobs Geared Chuck & Key
Reg. \$39.95—
Our Price **\$14.95**

Ask any expert and he'll always say "RAM for 50c pp. plus hdig. Heavy Duty Work." Not just an ordinary 2, 2 $\frac{1}{4}$ or 2 $\frac{1}{2}$ amp unit, but a powerful full 2.9 AMP. drill to do every heavy duty job in home, shop or industry. Built to take years of rough-tough use. Newer, more rugged motor gives $\frac{1}{2}$ " capacity in hard wood and $\frac{1}{4}$ " capacity in steel with a full load speed of 1200 R.P.M. Durable, mirror finished, lightweight aluminum housing. Features Universal, series wound AC-DC motor; heavy duty multiple thrust ball bearings; automatic release trigger switch with locking pin; 6 ft. 2 conductor, UL approved cord and plug. Standard 115 V. AC-DC. This powerhouse measures 9" in length yet weighs only 3 $\frac{1}{2}$ lbs. If you've ever needed a drill or find that your present $\frac{1}{4}$ " job just won't do the things you expect of it, ORDER THIS 2.9 AMP. $\frac{1}{4}$ " RAM DRILL TODAY! Limited quantities.

ALL PURPOSE, HEAVY STEEL TOTE-ABOUT \$1.98

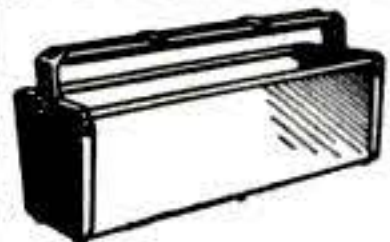

plus 35c pp. & hdig.

This attractively styled Tote-About measuring 16" x 5 $\frac{1}{2}$ " x 7" is ideally suited for household or garden tools, hobby craft and art supplies, children's toys, and many other indoor & outdoor applications! Constructed of heavy-duty steel with baked-on metallic finish. No sharp or rough ends. Adjustable handles with slot for saw, 2 dividers on tray handle hold nails, screws, bolts, etc. Easily assembled in just 5 minutes.

Send Check or M.O. C.O.D. fee extra **MONEY BACK GUARANTEE**
SCOTT-MITCHELL HOUSE, INC. Dept. E-7, 415 S. Broadway
Yonkers, New York

How Dangerous Are the Small Cars?

[Continued from page 78]

cident reports, light cars against heavy cars, this time by groups. Group for group, the accidents were nearly identical: same impact speed, same type of crash, same body style. The planned difference was car weight. The unplanned difference was injuries. That is, there might turn out to be an injury difference, light car versus heavy, or there might not.

For instance, take accident configuration F, which stands for cars running into trucks. In the light-car group, there was one case, No. 151205, involving a sedan striking a truck at 40 to 50 m.p.h. With fog dimming visibility, a White semi-trailer pulled out of a side road into the path of a VW; the VW driver was slightly hurt.

In the heavy-car group, there were three comparable collisions, among them Case 122907. A '56 Chevy Bel Air went out of control on a curve and rammed the trailer of an International semi. The Chevy spun around and traveled backward 30 feet. Its driver was unhurt.

In all, 101 light-car accidents could be matched against 1,361 heavy-car accidents in 74 categories. The injuries in each accident were graded (on a scale that scores zero for no injury, one for a minor injury, and on up to six for a fatal injury). The scores were averaged for each accident group, added to give totals, then compared to see if there was a difference. There was:

- Rollovers. Injuries averaged several grades higher (more severe) in heavy cars than in light cars. The numerical difference is not conclusive—the results could have arisen through chance—but light cars look better here.

- Collisions. Injuries averaged several grades higher in light cars than in heavy cars. Again the difference is not conclusive, but heavy cars look better here.

- All accidents (rollovers and collisions lumped together). Injuries averaged slightly higher in light cars than in heavy cars. This result is close to conclusive, but doesn't quite make it. Again the heavy car looks better—slightly.

What it means. Small-car buffs, whose fierce loyalty to their adored bugs is legend, will stomp all over these findings with their imported rope-soled shoes. The statistically sophisticated will argue that

STICKLEBACK FILE-RASPS



coarse on one side, fine on the other, will not fill up. Excellent for plastics, formica, masonite, fiber-glass & soft metals. Unlimited uses. **Single handed No. 6 TOOL** length: 7¾", width 7/8" \$1.89; No. 7 9¾" x 7/8" \$1.98; No. 8 12½" x 1" \$2.69. With **180° tiltable handles** 11½" x 1½" \$3.25.

Send check or money order. We ship prepaid. Ten day full money back guarantee. Catalog free on request. BeeVel Products, 2249 Federal Ave., Los Angeles 64, Calif.

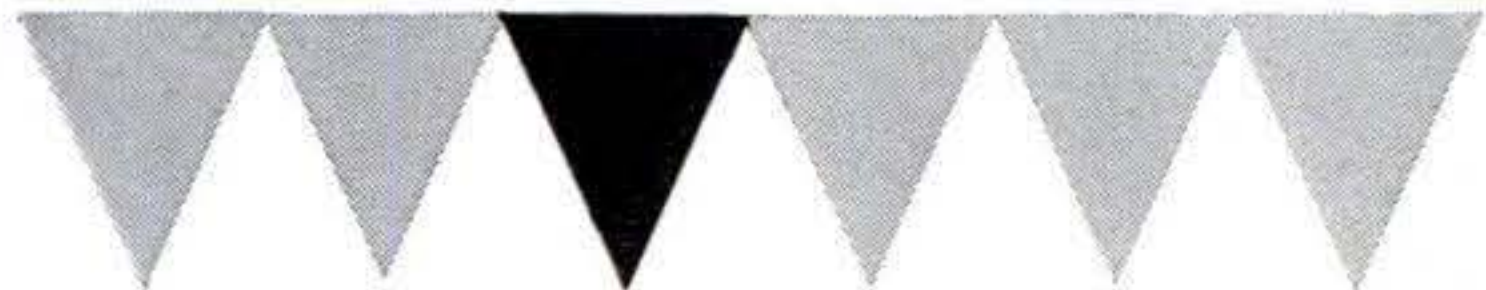

universal symbol  for precision loudspeakers
write for free catalog

"JBL" means JAMES B. LANSING SOUND, INC. 3249 Casitas, Los Angeles 39

Your Dollar Will Feed A Refugee

War and political refugees overseas urgently need the direct help, the personal encouragement, of CARE food packages—\$1 for 22 lbs. of farm staples, **Delivered In Your Name.** Mail your dollars to "Refugee Campaign," CARE . . . today!



660 First Ave.
New York, N. Y.

Printed as a public service

ELECTRIC WELD - BRAZE & CUT

REPAIR MOST EVERYTHING MADE OF METAL



Home Appliances, Auto parts, Farm-garden equipment, toys. Make and repair playground equipment, lawn chairs, tables, ornamental iron work, gates, wagons, etc. Solder, heat, bend, and straighten, with terrific heat from arc torch. Cut and weld up to ¼" steel plate. A million uses for Home, auto, farm, inventors, factories, etc. Works from any home 110 volt plug-in. Complete with dark welders mask, arc torch, supply of carbon welding and brazing rods. Solder, flux, and complete Welding Instruction Book. Attractive—portable—efficient—durable—1 year guarantee. Wt. only 8 lbs.

SEND ONLY \$3.00 (cash, ck, mo) and pay postman \$6.95 plus COD postage on arrival or send \$9.95 plus \$1.50 postage and we will send postpaid. Ideal gift for mechanically minded home owners, relatives, friends. Order now for early delivery. Available only from:

MIDWAY WELDER Dept. DPS-7 Kearney, Nebraska

Looking for Something?



GARDEN EQUIPMENT



pottery, poultry, elevators,
hoists, corsets, refrigerators
whatever you need—

Find It Fast
In The
Yellow Pages



Advertisers displaying this emblem make your shopping easy.



HANG FIXTURES SECURELY... USE
MOLLY Screw Anchors
and JACK NUTS

PERFECT FASTENERS to hold anything on walls, floors, ceilings



With Molly you can install fixtures exactly where you want... not just where studs are. Won't pull through. Spider backing reinforces area in which used. Fixtures can be removed and replaced in same anchor. Easy to install without disfiguring wall. Inexpensive, guaranteed. Ask your hardware dealer for genuine Molly... the name is stamped on the cap.



New JACK NUTS HOLD IN HOLLOW-CORE FLUSH DOORS

Now you can fasten fixtures securely to flush doors! Jack Nuts need only 3/8" expansion space, grip any material up to 3/8" thick.

SEND \$1.00 FOR SAMPLE BOX OF 12



MOLLY Corp. • 204 N. 5th St. • Reading, Pa.

Enclosed is \$1.00 for sample box of (check one) Mollys Jack Nuts

NAME _____
 ADDRESS _____
 CITY _____ ZONE _____ STATE _____

8" TILT ARBOR SAW
SOLD BELOW COST!

Our 1957 model. Precision ground cast iron table. Massive cast iron mitre gauge. Patented motor drive fits any motor. Adjustable depth of cut; 0" to 2 1/4". Blade tilts 0° to 50°. Sold and guaranteed direct from factory. Sent express collect, less blade. If you are not delighted — for any reason — return for immediate refund. Send check or M.O. or write for free tells-all folder.

ONLY \$9.95
 Was \$24.95



AMERICAN MACHINE & TOOL CO., ROYERSFORD 2, PA.

Shrinks Hemorrhoids
New Way Without Surgery

Science Finds Healing Substance That Relieves Pain—Shrinks Hemorrhoids

For the first time science has found a new healing substance with the astonishing ability to shrink hemorrhoids and to relieve pain—without surgery.

In case after case, while gently relieving pain, actual reduction (shrinkage) took place.

Most amazing of all—results were so thorough that sufferers made astonishing statements like "Piles have ceased to be a problem!"

The secret is a new healing substance (Bio-Dyne*)—discovery of a world-famous research institute.

This substance is now available in *suppository* or *ointment form* under the name *Preparation H.** Ask for it at all drug counters—money back guarantee.

*Reg. U.S. Pat. Off.

How Dangerous Are the Small Cars?

the sample is too small, the results not significant.

Admitted. The Cornell researchers are quick to warn that they cannot now *prove* any safety differences between small and big cars. (To them, proof means 100-to-one odds against being wrong.) But they are confident that the *trend* they see is a reasonable one:

Heavy cars may be very slightly safer overall (because they offer greater protection against the most likely danger—collisions).

And the researchers remind you that:

- The best way to avoid getting hurt is to stay out of accidents.
- Any car—big or small—needs the standard safety package: belts, padding, positive locks.

The comment of a policeman, handwritten on Case 240014 (a three-times-rolled Austin whose driver was found dead 15 feet from the car), fits here. Wrote the cop: "Inside of car intact—seat tracks in place: If safety belt was used, fatality might have been prevented." **END**

Cellar lockers freeze food



WHEN this German hausfrau rented her apartment, she got a food freezer, too. Refrigerated lockers line the walls of the basement and each tenant has a key to a box. A diesel-electric plant keeps the storage wall at deep-freeze temperature.

WAR SURPLUS AND OTHER BARGAINS SAVE UP TO 90%

FAMOUS NAVY MK14 AIR COMPRESSOR

Great for tree, termite, airbrush & paint spraying; filling tires, aquariums, etc. Dual & remote control electric receptacles, 115v 60 cycle AC, heavy duty HP. Westinghouse Motor. Direct drive. Water & explosion-proof. Built-in air filter, adjustable pressure setting up to 47 lbs. 3 cu. ft. per min. Self-contained switch. Mounting brackets. These units made under license of Sperry Gyroscope Co. Wt. 66 lbs. gross. Approx. GOVT. COST \$585. Like NEW. \$21.95.

With portable steel hand cart (shown), rubber wheels, specially constructed for mounting this unit. Incl. 25' rubber air hose. 6' extension cord with plug & fittings. Wt. 76 lbs. Complete with cart—\$26.95.

With new internal-pressure spray gun with 3 adjustable spray tips. 1 qt. cap. \$35.95 complete.

GENERAL ELECTRIC ARC WELDING KIT

Rated 300 Amps. 24-32 Volts. Complete Kit consisting of 300 AMP Gen., 1 Voltmeter, Ammeter, Voltage Regulator, Rheostat Control, Giant Toggle Switch, Electrode Holder, 30' heavy duty welding cable, Welder's Helmet, wiring diagram. Approx. GOVT. COST \$450. Kit complete \$37.50.

WELDER'S HELMET Heavy duty construction. Flip-up type. Adjustable head-band. A \$12.75 value. NEW \$6.95 ppd.

ARC WELDER KIT—\$26.00 Build your own complete make-up package incl. 1 Aircraft DC Gen. 200 Amps. 24 V; Rheostat, Toggle Switch, 1 Ammeter, Electrode Holder, Welder's Shield, 30' New Welding Cable, Voltage Reg. Simple instruction wiring diagram. Wt. under 100 lbs. Approx GOVT. COST \$475. All units guaranteed pre-tested. \$26.00.

WELDING CABLE DOUBLE-O, heavy duty, neoprene jacket, fiberglass insulation. NEW. Approx. GOVT. COST \$40. 50' lengths. Will handle 400 Amps. or better. \$14.50.

HEAVY-DUTY RHEOSTAT Ideal for regulating voltage on electric welders. Rated 5.75 Ohms, 100 Watts with double windings & dual female 25 amp., 125 V. receptacles. 7" hi x 5 1/4" D. Shpg. wt. 2 1/2 lbs. Approx. GOVT. COST \$25. Brand New. \$2.25 ppd.

BENDIX GEROTOR PUMP & MOTOR

Use wherever fluid pumping required. Excellent for hydraulic installations. Has 3/4" pipe connections, built-in relief valve adjustable up to 1500 lbs. Max. cap. 6 GPM. 1 1/2 H.P., 24 V. motor. Use on 12 to 36 V. Approx. GOVT. COST \$350. NEW \$10.95.

140-1 REDUCTION GEAR For beaching boats, winches, hoists. Ideal for motor in golf or boy's electric car. DC motor & clutch. Easily reversible wiring diagram furnished. Hi torque, 1° speed. Runs on 6-12 or 24 V. Wt. 65 lbs. gross. Approx. GOVT. COST \$300. Like NEW. \$12.00. Matched splined gear for above—\$3.00 ea. *225-1 Reduction Gear—\$13.50

ELECTRIC PUMP WITH CONTROL UNIT Runs on 12 or 24 V. Centrifugal type. Pumps 500 GPH. Complete with on and off switch rheostat, 2 speeds (hi & lo). Mfd. by Ingersoll-Rand. Shpg. Wt. 7 lbs. Approx. GOVT. COST \$195. NEW \$8.95.

NEW DESCRIPTIVE CATALOG Thousands of bargains in war surplus & other items. Hundreds of pictures. Send 25c in coin for your copy today! Ppd. prices in USA only. Other prices FOB Culver City, Calif. Send cash, check or money order. 50% deposit on COD.

AIRBORNE SALES CO., INC. DEPT. PS758
8501 Stellar Drive, Culver City, Calif.

MAKE \$10-\$20 AN HOUR

Full or part time, work anywhere.

Serrate and sharpen table, steak knives. Every restaurant, hotel, etc., repeat customers. Write today for proven daily profit plan. Guaranteed.



58-H So. Raymond Pasadena, Calif.

CUTTER-CRAFT

MACHINISTS and TOOLMAKERS

.0003 HOLE LOCATION IN ONE MINUTE

Thousands of companies and individuals have proven and accepted our EDGE FINDERS for years. Ask for literature with users list and dealer in your area. Hardened and ground on all surfaces including contours for balance. .500" size \$2.50. Deluxe .200" size \$10.00. Vise stop for holding same hole location in several pieces \$2.95.

POSTPAID EXCEPT C.O.D. CHARGES

GLOVER MFG. CO. 423 PARK AVE. MEADVILLE, PA.

THE ORIGINAL PACKAGED BOAT KITS

MADE ONLY BY *Custom-Craft*

NEW 1958 CATALOG 70 MODELS



- NEW FOR 1958! CATALOG FOR
- SEA-RAY FIBERGLASS PLASTIC BOATS, BOAT KITS AND HULLS
- CLOTH RESIN FIBERGLASS ETC.
- WORLD'S LARGEST LINE...
- DESIGNED FOR AMATEURS!
- Over 200 Boats, Kits Frame packs 8' - 21' All Types: Prows, Skiffs, Cruisers, Etc. No jigs required.
- Finest Materials Available. Easy To Build!
- Also Semi & Custom Finished Boats at new LOW prices
- Constructed in one day. 12 models from 10 ft. Built in performance.
- Utilities and Runabouts. No Upkeep Professional Results
- SEND 35c FOR 64 PG. CATALOG AND 24 PG. "SEA-RAY" Fibreglas Kit Catalog. Contents include hardware, paint fibreglas materials. Send \$1.00 for both catalogs plus "BOATING HANDBOOK." DEALERS-AGENTS INQUIRE

CUSTOM-CRAFT · BUFFALO 7M NEW YORK

AROUND THE WORLD IN LESS THAN A WEEK

Envelopes flown from San Francisco or New York in the first official U. S. Airmail Route Around the World in June 1947. Scarce, and wonderful additions to any stamp collection. *Either* cover \$1.50 or \$2.75 for the pair. 5 all diff. US AIRMAIL FIRST FLIGHT covers for \$1. or 14 for \$2.50 Official P. O. Cachet and backstamps on each. Full refund if not completely satisfied. Let us help you build your cover and stamp collection. Lists free.

K. M. Walsh Box 308 Tuckahoe, N. Y.

NEW DELTAGRAM YEARBOOK

All of 1957's top-flight issues of this popular home workshop magazine handsomely bound in durable, hard covers. Fully illustrated and packed with helpful ideas. Features "how to" projects complete with detailed drawings, step by step instructions and bills of materials. Only \$1.50—write: Rockwell Manufacturing Co., Delta Power Tool Division, 504G N. Lexington Ave., Pittsburgh 8, Pa.

"WE PAID FOR OUR HOME with a Foley Saw Filer"

FOLEY MFG. CO.
749-8 Foley Bldg.
Minneapolis 18, Minn.

Send Free Book "MONEY MAKING FACTS" and Time Payment Plan.

Here is the true story of Leslie Patrick—as told by his wife. "I can truthfully say Mr. Patrick made a wonderful investment with his Foley Saw Filer. In 1946, we had only a Model A Pickup and all our belongings were in it. Since then, my husband has done so well with his Foley Saw Filing Machine and repair shop that we bought a house and paid for it; bought a new car and built an addition to our house; and he has got a lot of new machines in the shop. Nicest of all, it is all paid for."

Make from \$3 to \$6 an hour

With the Foley Automatic Saw Filer you can sharpen hand, band, and circular saws just like new. Start in spare time, in your garage or basement. No experience needed. Build up a steady, repeat CASH business which will buy YOU a home or new car. **Time Payment Plan.**

Send coupon for FREE BOOK. No salesman will call.

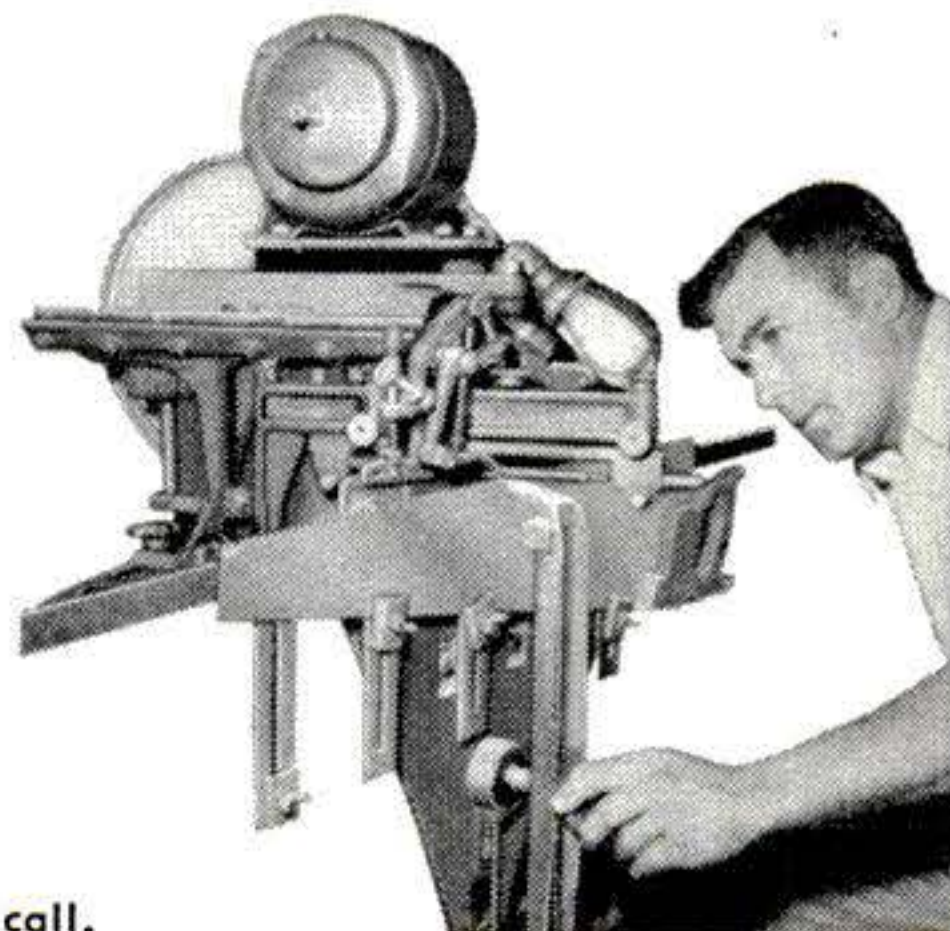

Name _____
Address _____

30" FAN!

\$12⁵⁰

**BUILD IT YOURSELF
SAVE 80%**

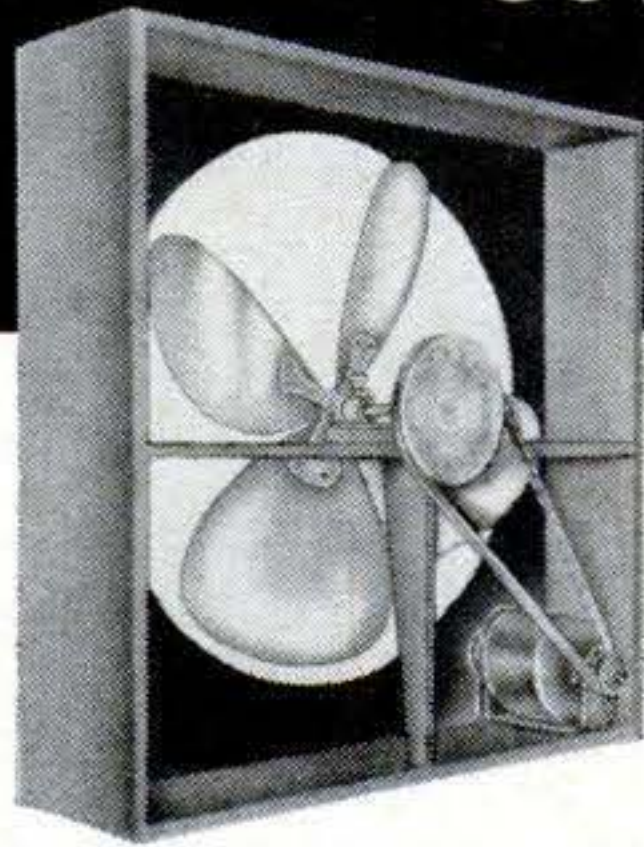

ASSEMBLE YOUR OWN FAN—IT'S EASY

The biggest fan value in the country. Enjoy a breeze all summer and save up to 80% by assembling your own fan. Kit gives you easy to follow instruction sheet plus all necessary precision parts less lumber and motor. Use as attic or window fan. Money back guarantee.

- 30" fan cools average home or barn.....\$12.50
- 24" fan cools small home or barn.....\$11.50
- 20" fan cools apts., offices, etc., or barn..\$11.00
- 36" fan cools home or barn.....\$17.00

Send check or money order. Shipped postpaid continental U.S. \$3.00 deposit on C. O. D. Free literature.

THE FAN HOUSE 527 St. Joseph St., New Orleans 12, La.

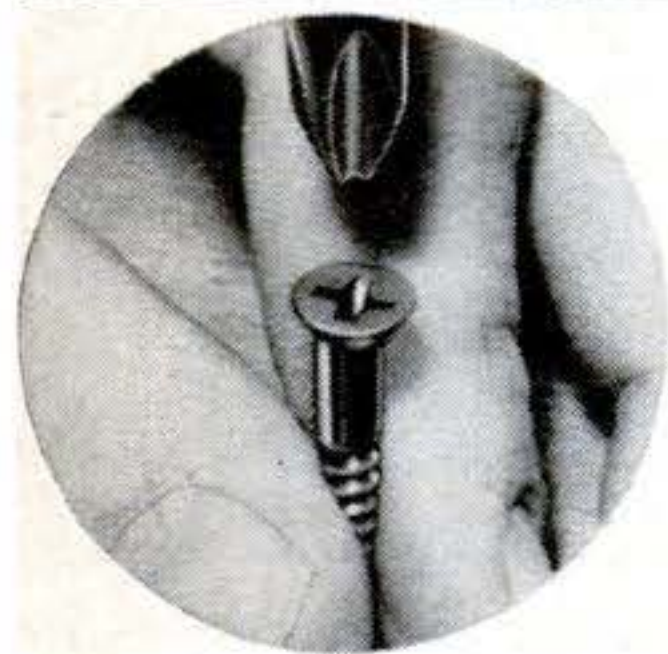

*Make it fast...
Make it last!*

use

SOUTHERN SCREWS!

Ask your hardware or building supply dealer for top quality Southern Screws for every workshop project. Remember... only a screw holds like a screw!

- Wood Screws • Machine Screws • Tapping Screws • Dowel Screws • Drive Screws • Stove Bolts • Carriage Bolts • Hanger Bolts



Sold Through Leading Wholesale Distributors

BOLT & WIRE CUTTER

Exclusive: Extendable Handles for Extra Leverage

CADMIUM PLATED. Center cut type bolt cutter for soft or medium hard rods and bolts, alloy wire, and other metals. Cutting edge has equal bevel on each side for extra strength.

FOLDED—It fits into your pocket or tool box—safety latch locks closed when not in use. Capacities: medium hard bolts in thread 3/8"; medium hard metals 5/16". Length closed: 10 3/4"; extended 15 3/4".

A \$9.95 NOW 3.95 2 FOR
VALUE ONLY PPD. \$7.00



SURPLUS

BRAND NEW!

ITEM #478

EXTRA RUGGED

FREE! NEW SUMMER 1958 CATALOG

60 VALUE-PACKED PAGES of unsurpassed War Surplus and newly manufactured Equipment. Bargains for farm, home, factory, workshop. Write letter today.

GROBAN SUPPLY CO., Dept. PS-7, 1139 S. Wabash, Chicago 5, Ill.

New Ideas on Keeping Cool

[Continued from page 74]

protective responses are increased blood flow to the skin (which carries internal heat to the surface) and increased perspiration, which cools you by evaporation.

You normally burn about 300 calories an hour in the working day. But you can get rid of as much as 1,000 calories in an hour by sweating. So "sweating it out" isn't merely a figure of speech.

That four-day acclimatization, to summarize from a report by Dr. David E. Bass and Dr. Elsworth R. Buskirk, of the Quartermaster research center, goes like this:

On the first day of a heat wave, there is a dilation of the blood vessels in the skin. The blood transfers heat to the surface, where it is lost by sweating. Perspiration increases, along with the heart rate and the cardiac output—the amount of blood being pumped.

But the *amount* of blood available does not immediately increase. So when exercise calls for more blood in the muscles, there is a growing shortage in blood volume and a lack of blood in the viscera and brain. This may cause dizziness, a rapid pulse, and decreased heart output.

The demand for blood in the muscles diverts blood from the body surface and so the transfer of heat to the skin is impaired, with a rise in body temperature. Thus on the first day the heat load imposed by exercise may be too great, resulting in discomfort or collapse.

But as you become acclimatized, blood volume increases. Now, the response to muscular demands still leaves enough for cooling, and a lower body temperature results because there is better heat transfer to the skin. The pulse rate goes down. There is more sweating in the first week, with little change thereafter.

Ordering your body to adapt by graded exercise or work brings this adjustment into action. In five days you can be acclimatized, more comfortable and capable of more activity than you would have thought possible the first day.

That's especially important for athletes who have trained in cool climates, say Doctors Bass and Buskirk. Conditioning for performance in the heat can make all the difference between loss and victory. If two teams or individuals of the same skill and physical conditioning are to compete in hot weather, the acclimatized team

CLEANS YOUR CARBURETOR while you drive...

Hard starting, stalling, high gas consumption and poor performance all come from a dirty, gummed-up carburetor. And every carburetor gets dirty—inside. GUMOUT dissolves gum and varnish deposits quickly and completely. You just add GUMOUT to your gas tank every two or three months. It cleans as you drive! There's nothing like GUMOUT. Available at all auto supply stores, or wherever automotive products are sold.

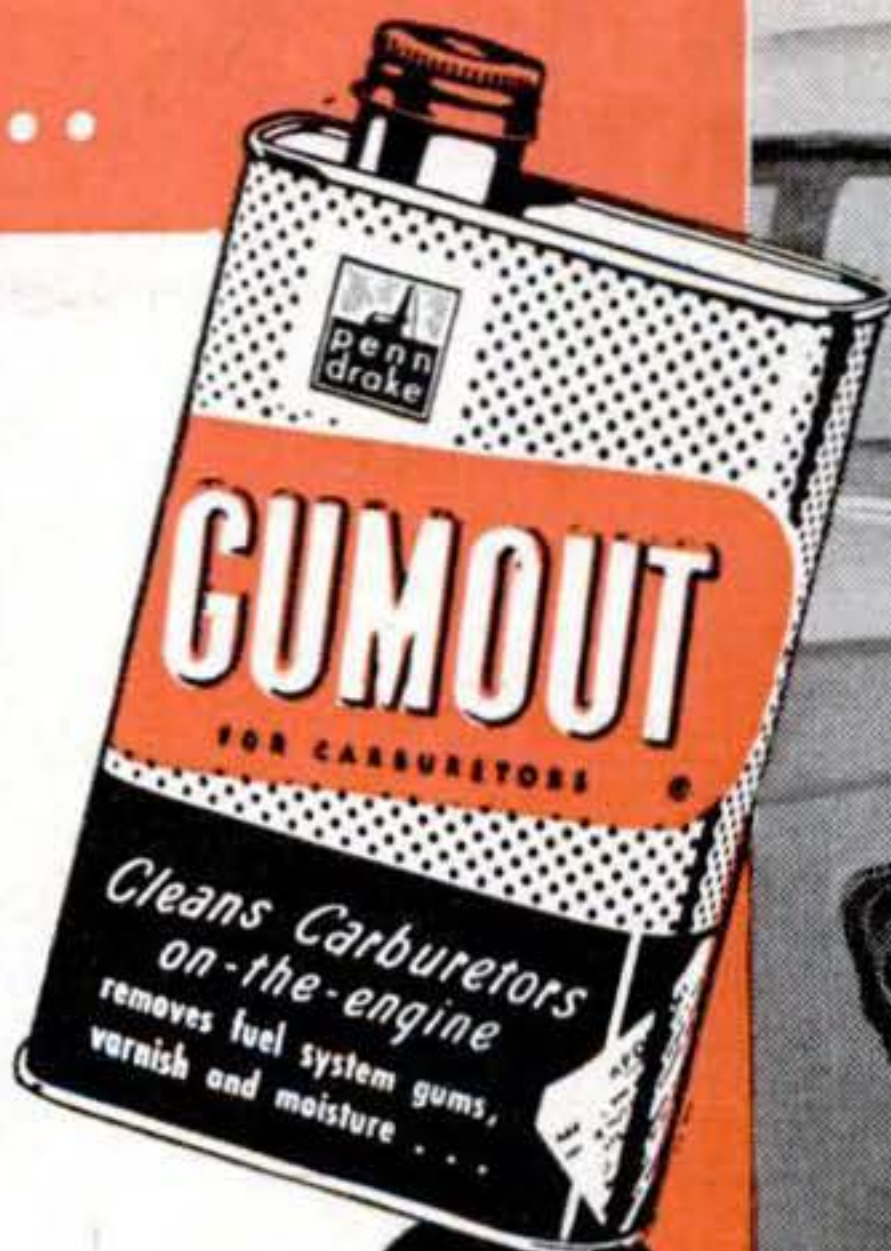

GUMOUT is great for power mowers, too. Insures trouble-free operation, full power.

PINT
\$1.50

Write for FREE 46-page Carburetor Handbook.

8-OZ.
89c



GUMOUT DIVISION • Pennsylvania Refining Co., 2670 Lisbon Road, Cleveland 4, Ohio

GENUINE ALNICO MAGNETS

AMAZING, PERMANENT, NON-ELECTRIC, HIGHLY PRACTICAL. Conduct interesting experiments. Hundreds of uses. Retrieve valuable steel items such as guns, tackle from fresh or salt water; tools from tanks & drains. **GUARANTEED.** Try any magnet one week. Money back if you are not well-pleased.

No. S-710 (Wt. 53 oz.) Has pull of 225 lbs. on steel block	\$18.00
No. S-625 (Wt. 70 oz.) Has pull of 125 lbs. on steel block	\$10.00
No. S-575 (Wt. 18 oz.) Has pull of 75 lbs. on steel block	\$7.00
No. S-500 (Wt. 13 oz.) Has pull of 50 lbs. on steel block	\$5.00
No. S-300 Kit of Flat Bars 5 Pairs (10 Magnets)	\$3.00
No. S-250 Kit of Round Rods 5 Pairs (10 Magnets)	\$2.50
No. S-47 Hot Pad Magnets. 10 for \$1.00	50 for \$4.87
No. S-35 Hobbyist assortment of 8 small magnets	\$1.50

Send M.O. or check. We pay postage. Sorry no C.O.D.'s.

MIAMI MAGNET COMPANY, 3240 N.W. 27th Ave., Miami 42, Fla.

"TI-NEE" BATTERYLESS TUBELESS LIFETIME RADIO

"TI-NEE" RADIO IS GUARANTEED TO WORK FOR YOUR LIFETIME! USES NO TUBES, BATTERIES OR ELECTRICAL PLUG-INS. Never runs down! SMALLER THAN A PACK OF CIGARETTES! RECEIVES LOCAL RADIO STATIONS MOST ANYTIME, ANYWHERE WITHOUT EXTRA ANTENNA. Uses semi-conductor crystal diode HI-Q Tuner. Beautiful black gold plastic cabinet. Built-in Speakerphone.

SEND ONLY \$2.00 (bill, ck, mo) and pay postman \$4.99 COD on arrival or send \$6.99 for postpaid delivery. **SENT COMPLETE READY TO LISTEN—NOTHING EXTRA TO BUY EVER!** Extra long distance Aerial kit included free to receive stations up to 1,000 miles away. **AMERICAN MADE.** Available only from:

MIDWAY COMPANY, Dept. GPS-7, Kearney, Nebraska

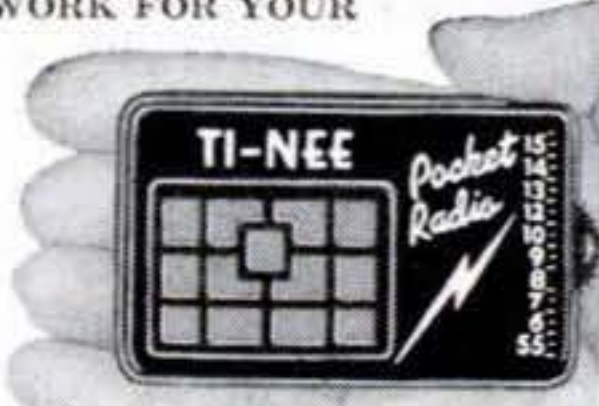

Convert Lawn Mowers into POWER UNITS with this Brand New BRIGGS & STRATTON

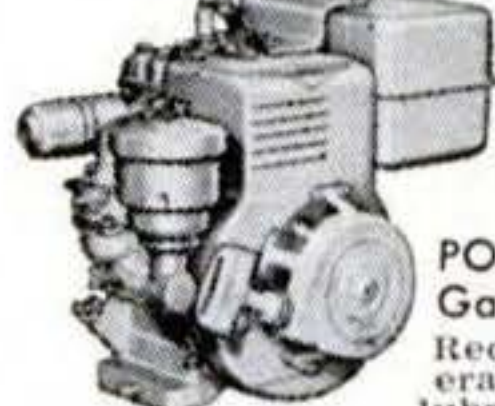

2 3/4 H.P., 4-Cycle Gas Engine

SAVE! Reg. Price \$72.00 while they last \$42.50

POWERS Farm, Home & Industrial Tools • Garden equipment • Pumps • Compressors
Recoll rope starting. Complete, ready to operate. Air cooled. Sure fire ignition. Positive lubrication. **GUARANTEED!**

GOV'T. SURPLUS! Limited Supply! Order from this Ad!
Free Catalog! Phone Taylor 9-1365
ROBERTS ELECTRIC CO., 849 W. Grand, Dept. PS-819, Chicago 22

JOINT AND SHARPEN ALL SAWS

SUPER FILER NO. 9
SO EASY to joint and file saws like new Two hardened steel rollers keep teeth same height. All teeth cut, saw runs true and smooth. \$2.95 ppd.

"TRU-CIRCLE" SAW SET
Automatically sets teeth at 10° or more. \$2.95 ppd.

SUPER FILER NO. 11
For both hand and circular saws. Steel rollers give all teeth correct height, pitch and bevel. \$9.95 ppd.

SUPER DRILL GRINDER
Sharpens round-shank drills like new, using hand or power grinders. \$2.95 ppd.

send for **FREE CATALOG**

A. D. McBURNEY, 5908 Hollywood Blvd., Hollywood 28, Calif., Dept.:S-78

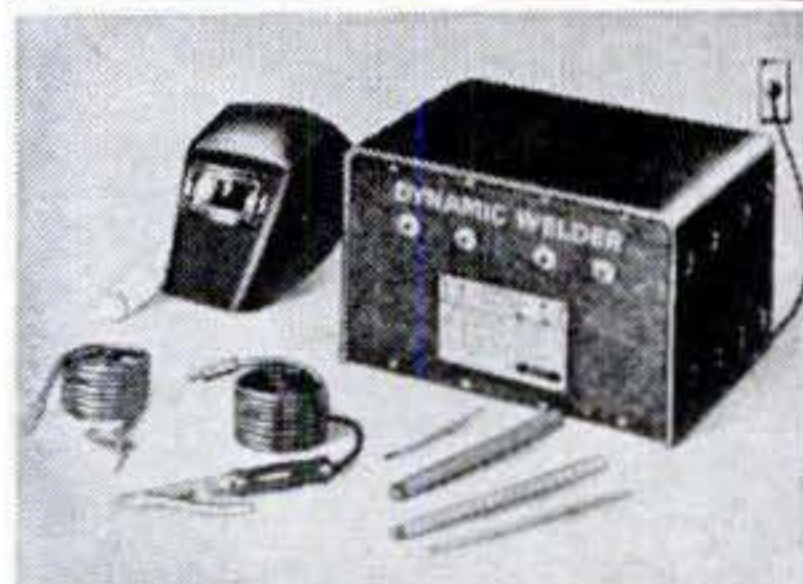

WELD IT YOURSELF IN A JIFFY!

Weld, Cut, Braze, Solder; Iron, Steel, Brass, Bronze, Aluminum and other metals safely and easily. Make your wrought iron furniture, porch railings, fences, knick-knacks and other metal specialties. With this fine equipment anyone can do professional-like work with little practice. The Dynamic is an industrial type transformer arc welder designed to operate from any properly wired 110 volt AC line.

NOW as a SUMMER SPECIAL you will receive an \$8.00 Twin Carbon Arc Torch FREE to complete your welding workshop. Order TODAY!

Literature on larger equipment available on request.

DYNAMIC WELDER COMPANY, 1808 S. Federal Street, Dept. D3-G, Chicago 16, Illinois

EASY PAY PLAN
Low down-payment. Pay as you weld. Money back guarantee. Complete outfit, including special SUMMER GIFT.
Only \$38.50
F.O.B. Factory

NEW FIR PLYWOOD
BOAT PLANS
 25¢ ea. ★ Designed by leading naval architects for style and top performance
 ★ Specially planned for "do-it-yourself" construction with fir plywood



Large, easy-to-follow scale plans have step-by-step illustrated instructions and complete material lists

OUTBOARDS

11' (Plan 35)—Fast, roomy car-top utility model.

13' (Plan 40)—Ideal for skiing and fishing or family fun.

16' (Plan 55)—Roomy deluxe runabout. Seats 6 in comfort.



CABIN CRUISERS

18' (Plan 60)—Easy-to-build family day cruiser.

20' (Plan 65)—Sleeps 2. Has galley, head.

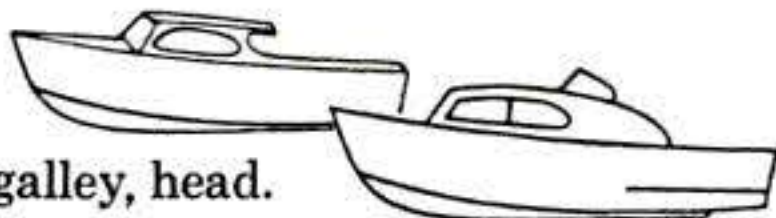

ROWBOATS

8' (Plan 30)—Light, all-purpose pram. Takes small outboard.

14' (Plan 45)—Roomy, flat bottom punt for hunting and fishing.

PLANS 25¢ EACH. Order by number. Also write for free folder describing boats in detail. (Offer good USA only). Douglas Fir Plywood Association, Dept. 11, Tacoma, Washington.

Use only Exterior plywood (EXT-DFPA®) for boats. Comes in several sizes, grades—including premium quality solid-core "Marine Exterior" for hull construction.



NEW, IMPROVED CALCULATOR FOR WOODWORKERS only 25¢
 Instantly gives information on lumber, nails, concrete mixes, painting materials, etc. Convenient, simple to read. Just set dial for nail specifications, to convert linear to board feet, find bit sizes for screws, compare characteristics of woods. 6" diameter heavily varnished cardboard. Send 25¢, no stamps, please to Greenlee Tool Co., 2127 Columbia Avenue, Rockford, Illinois.



TINY MOTORS & ACCESSORIES AID SCIENTIFIC PROJECTS

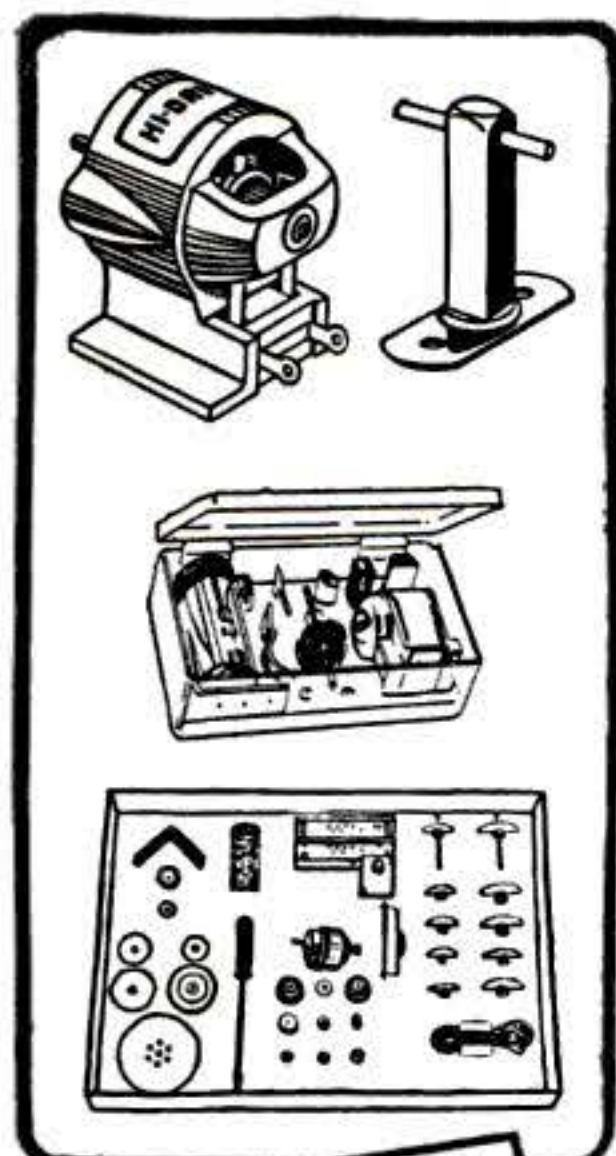

Designed for today's trend toward a better understanding of basic science facts by everyone interested in engineering. Many types of motors and drives to suit small projects.

- *No. 8-100 Hi-Drive Motor, 3-6v. \$2.50
- No. 9-100 Same for 12V. \$3.00
- No. 3-100 Tiny Atom Motor, 1 1/2-3V. \$2.00
- For 6V. . . \$2.50 For 12V. . . \$3.00
- *No. 3113N Tiny Atom motor assembly kit with many acc. . . \$3.50
- No. 26 Couplings kit \$1.50
- *No. 12 Solid shaft supports kit \$2.50
- No. 77 Set of 7 large pulleys. . . \$3.00
- No. 88 Kit of 8 pulleys—2 belts \$2.00
- *No. 700 Super-Power kit with motor and all accessories. . . \$10.00
- No. 3000 Vari-speed gear unit. . \$4.00
- No. 1049 Gear train with Hi-Drive motor No. 8-100. . . \$5.95
- Same with No. 9-100 Motor. . \$6.45
- * Item illustrated. Ask for FREE Cat.
- All motors have ALNICO magnets.



Remit with order and we pay postage in U.S.A. No C.O.D. Add 3% Sales Tax for delivery in Ohio. Write Dept. PS

For quick delivery see your local dealer — or order direct

WILSON'S OF CLEVELAND
 425 Lakeside Ave., N.W. • Cleveland 13, Ohio

New Ideas on Keeping Cool

or individual suddenly becomes superior.

In the fierce Sugar Ray Robinson-Joey Maxim fight in the summer of 1952, the doctors point out, Robinson was ahead on points until the hot, humid weather began to take its toll of him. Up to then much the more active, Robinson was reduced to such a helpless state that he couldn't respond to the 15th-round bell.

In December, 1956, Massachusetts' outstanding school football team went to Florida to play the best school team in that state. Since it was a post-season game, the Massachusetts boys were not acclimatized. Played on a hot, humid day, the game was close fought until the third quarter. Then, as if unopposed, the Florida team romped on to victory.

"Our current thinking on how to beat the heat is to understand our natural cooling system, try not to interfere with it, and give it every chance to work at maximum efficiency," says Dr. Austin Henschel, another of the heat researchers. "Along with this, we are recognizing the importance of permeability and evaporation."

Experiments behind these findings were carried on in Arizona deserts, Panama jungles and Arctic ice fields, but almost any weather conditions can be duplicated in the Army's consolidated Research and Engineering Center at Natick, Mass. Here climatic chambers can produce temperatures as low as minus 70 and as high as 165 degrees, with any desired humidity.

Experimental hot-weather clothing is one of the end products of this research. A fantastic new suit borrows from the chemise and the old-fashioned hoop skirt by having stays that keep the cloth an inch and a half away from the body. The stays let the wearer's skin breathe through "chimney" passages in pants and jacket.

A tent that works on the same principle allows air to circulate along its walls and roof through built-in channels.

The Army's findings, vital to military personnel, have a highly personal meaning to civilians as well. Hot-weather adaptation can be a boon in these days of rapid air transport for anybody who must go on short notice from a cold to a hot climate. It can be equally important to those of us who want to keep active, efficient, and comfortable on hot summer days right around home.

END

SURPLUS SALE

WAR SURPLUS
EXCESS INVENTORY
BANKRUPT STOCK

SUMMER CLOSE-OUT SPECIALS

To reduce our tremendous Govt. surplus inventory, we offer hundreds amazing close outs. Send for summer list. Typical buys all prepaid to you are:

- Surveyors Levels—Leading make. \$42.95
- 12"x24" Stainless Steel Air Tank. \$16.95
- Blackhawk Hand Hydraulic System. \$26.95
- New 1957 Outboard Motors—20% off
- Modern Dial Extension Telephones. \$ 9.95
- Hand Crank Fish-Worm Shockers. \$ 3.89
- Hydraulic Speed Reducer. \$49.50
- 7x50 Finest Binoculars. \$26.81
- 8400 gal. Centrifugal Pump. \$24.61
- 300 amp. Air Craft Generator. \$26.51

TRUCK WINCH



- Runs 6 or 12 volt batt. Reversible. Capy. over 1000 lbs. Cost \$280. SALE \$46.71 FOB

IRRIGATION PUMPS

- 2 1/2". 16,500 gph. Centrifugal. All bronze ball bearing. New. Govt. cost \$103. SALE. \$49.50 FOB



SPECIAL OF THE MONTH!

GOV'T AIR COMPRESSOR

- Special new laboratory motor-driven compressor with filter, air drier, pressure gauge, hose, G.E. 110-v 60-c motor, etc.
- Very useful unit for light paint spraying, insecticide spraying, air brush work, diving, etc. A real super buy. Wt. 44 lbs. Govt. cost over \$200. SALE \$17.97 FOB



GOLF CAR MOTOR

- Runs 6 or 12 volt batt. Powerful gear reduction. Reversible. Cost \$250. SALE. \$19.46 FOB



ORDER FROM AD or get free catalog.

BURDEN SALES COMPANY

829 West "O" St., LINCOLN, NEBR.



HELP STOP DEATH ON THE HIGHWAY



WHERE TRAFFIC LAWS ARE OBEYED DEATHS GO DOWN!

SUPPORT YOUR LOCAL SAFETY ORGANIZATION

Published as a public service in
cooperation with The Advertising Council

Sharpen YOUR SAWS with QUICK-WAY*



Now you can sharpen, joint, gum and retool all circular saws to 12" dia. Precision results. Safety Guide, Mounting Block and Grinding Wheel included. Model PG-12 \$19.95 Postage Paid. Send for Circular FREE! Special Saw Set with each QUICK-WAY unit purchased; (\$2.75 if ordered separately).

QUICK-WAY SAW CO. 234 Tompkins St. Cortland, N. Y.

KEEP YOUR... on BENJAMIN



"First in
POWER and
ACCURACY"

for HIGH H C COMP

AIR GUNS & CO₂ GAS GUNS—Top Quality at LOWEST PRICES!

BB or 177 or 22

BENJAMIN SUPER
 Single Shot CO₂ Carbine Gas Rifle (BB) with Reg. Stock **\$14.95**
 Deluxe (BB) Model with Custom Stock (Shown) \$17.95

All Models Benjamin CO₂ Carbine Gas Rifles and Benjamin CO₂ Rocket Gas Pistols Use Standard Size CO₂ (Soda) Cartridges (available everywhere). 2-Stage HI-LO Jet Power—High for Small Game—Low for Target—Up to 50 Shots from Each Cartridge. No Pumping—Safe—Accurate—Economical—Non-Toxic.—12 Models—BB or 177 or 22.

Benjamin Air Rifles and Benjamin Air Pistols are Recognized All Over the World for Finest Workmanship and Highest Quality at Lowest Prices. Adjustable Power with Amazing Optimum Force. Fully Guaranteed—Safe—Accurate—Economical. Easy to Use Anywhere—12 Models for Target and Small Game 22 or 177 or BB from \$18.50.

FREE! Catalog All Models Benjamin Air Guns & CO₂ Guns & Supplies. Also, Money-Saving Offer on Hunting & Fishing Knives, Accessories, etc.

Send Gun Catalog and Special Knife Offer!

BENJAMIN AIR RIFLE CO., MAIL TODAY!
 852 MARION ST., ST. LOUIS 4, MO., U.S.A.

Name _____
 Address _____
 City _____ State _____

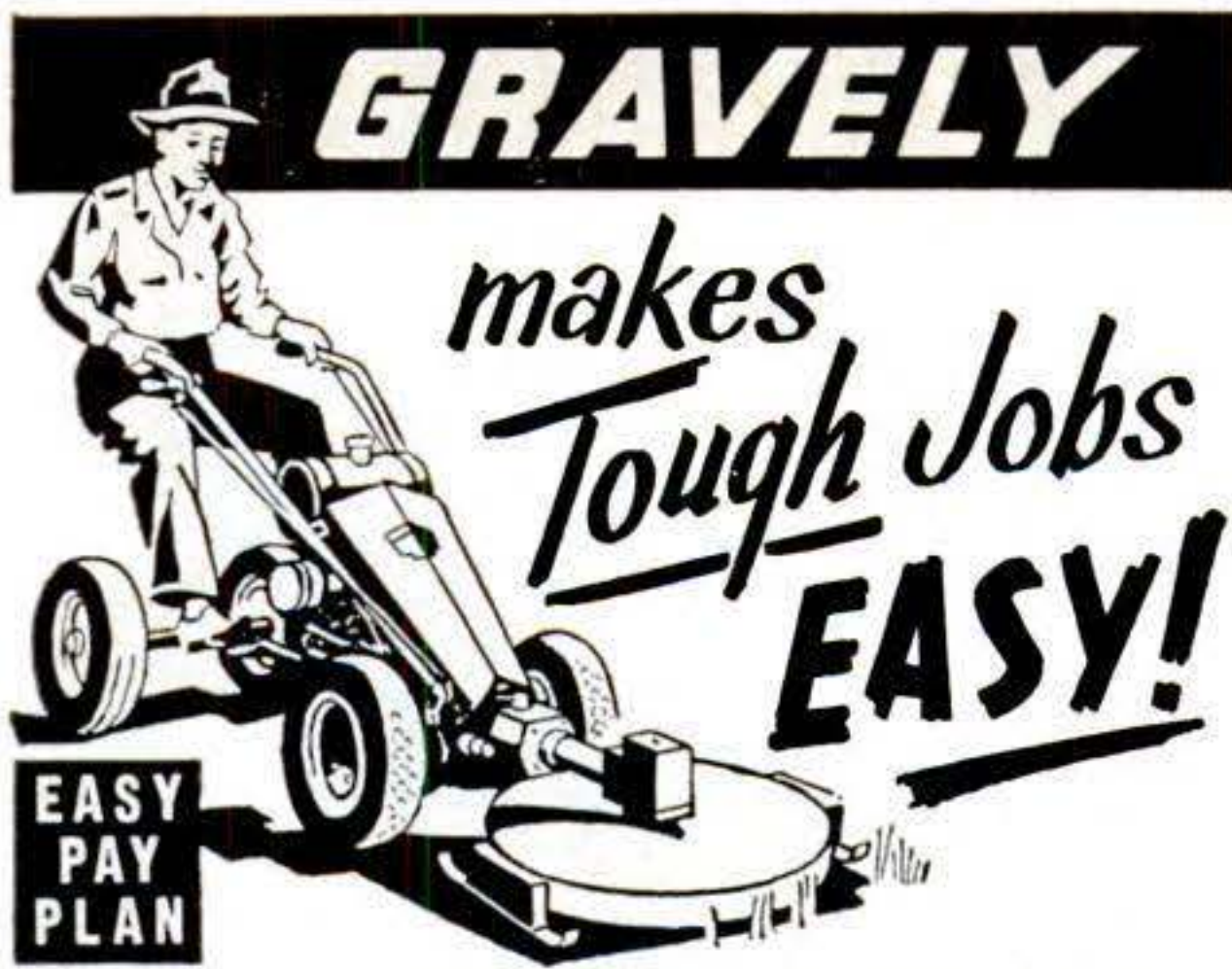

Powerful 5-HP Gravelly, America's most versatile small tractor, does every lawn, garden and field job *faster, easier, better!*

Choice of 30 performance-proved tools. All-Gear Drive, Power Reverse, Push-Button Starter optional.

New 24-page "Power vs Drudgery" Booklet shows how Gravelly power and performance can solve YOUR problems. Write for it today!



GRAVELLY TRACTORS, INC.
BOX 784, DUNBAR, W. VA.

FIELD-TESTED SINCE 1922



**CLOGGED SEWERS?
CLEANED INSTANTLY
SAVES PLUMBING BILLS —**

CHICAGO—July 1st. Just introduced is a Free Booklet on a New Discovery which enables the Home Owner, Janitor, or Factory Maintenance to clean any Clogged Sewer Drain. Yet anyone can operate this new Plumbers Flushing Gun which releases air pressure on a solid shaft of water cleaning the most stubborn stoppages up to 200 feet. TOILETS, SINKS, URINALS, BATHTUBS, FLOOR DRAINS, and HOUSE-TO-STREET SEWERS clogged with Grease, Rags, Sand, Roots, and paper melt away instantly when struck by the Hammer-like blow of this new unit. There is no need to remove wall or pipe, or Grease Trap. A special attachment allows water to flow from the faucet through the Gun while air is released on the pipe. Vents or stacks are no obstacle, as force tends to strike wherever the water lays. But now, what is this Plumbers Flushing Gun worth in **COSTLY PLUMBING BILLS SAVED?** Tear this Ad out—and write your name and address beside it for **FREE BOOKLET**. Obey that urge. No agent will call. A postcard will do (Chicago Phone Kildare 5-1702) **MILLER SEWER ROD CO., DEPT. PS-L, 4640 N. Central Ave., Chicago 30, Illinois.**

**YES, you can own a
MOTORCYCLE**

for only
\$179
and up



ZUNDAPP

Send for **FREE ILLUSTRATED LEAFLETS** on the world's 10 most exciting motorcycle, moped and scooter values. From 3 to 42 HP. 4 Models under 5 HP (approved by many states for boys at 14). **SALES-SERVICE AGENCIES FROM COAST TO COAST**



Write today:
BERLINER MOTOR CORP., Dept. PS1, 2432 Grand Concourse, N. Y. 58

When They Discovered Men on the Moon
[Continued from page 64]

improbable stories. Many strongly believe in such unscientific phenomena—not necessarily hoaxes—as reincarnated Irish lassies, flying saucers from outer space and houses haunted by whimsical poltergeists.

Not too many years ago, people tuned in a radio play and whole families fled from Martians. So the gullibility that made people suckers for the Moon Hoax is still operating. And hoaxes are still being perpetrated with great ingenuity. As Shakespeare wrote, "O what a goodly outside falsehood hath!" Finally, unexpected things may occur that seem to sup-

.....

Next Month in PS: Climb aboard sleeper No. 449—a ship-size trailer truck with a 35,000-pound cargo—for a midnight ride on our newest super-road, the Connecticut pike.

.....

port a fraud, as when people give false testimony because of an honest error—or dishonestly to win publicity.

THE best defense, then, against being fooled is the same today as it was in 1835: to be a little skeptical and to have a good basic scientific knowledge. For example, millions of people around the world accepted the Communist propaganda about germ warfare in Korea. But to anyone with knowledge of how bacteriological warfare actually would be waged, it was technically absurd that the United States was bombing North Korea and China with clams infected with cholera and spiders carrying anthrax.

True, the shrinking of distances by air travel and instantaneous communications would today render such a hoax as the *Sun's* short-lived. Reporters would flock to South Africa; within 12 hours the fraud would be exposed. But not Dr. Marchenko's amazing (and entirely fictitious) tale. The universities as well as the launching pads of the Soviet Union are very much closed to us. A Red denial of the story would mean nothing either way.

In any case, it will never hurt to apply scientific skepticism—and to keep in mind the astonishing story of how intelligent people were fooled by the biped beaver and the *Vespertilio-homo*. **END**

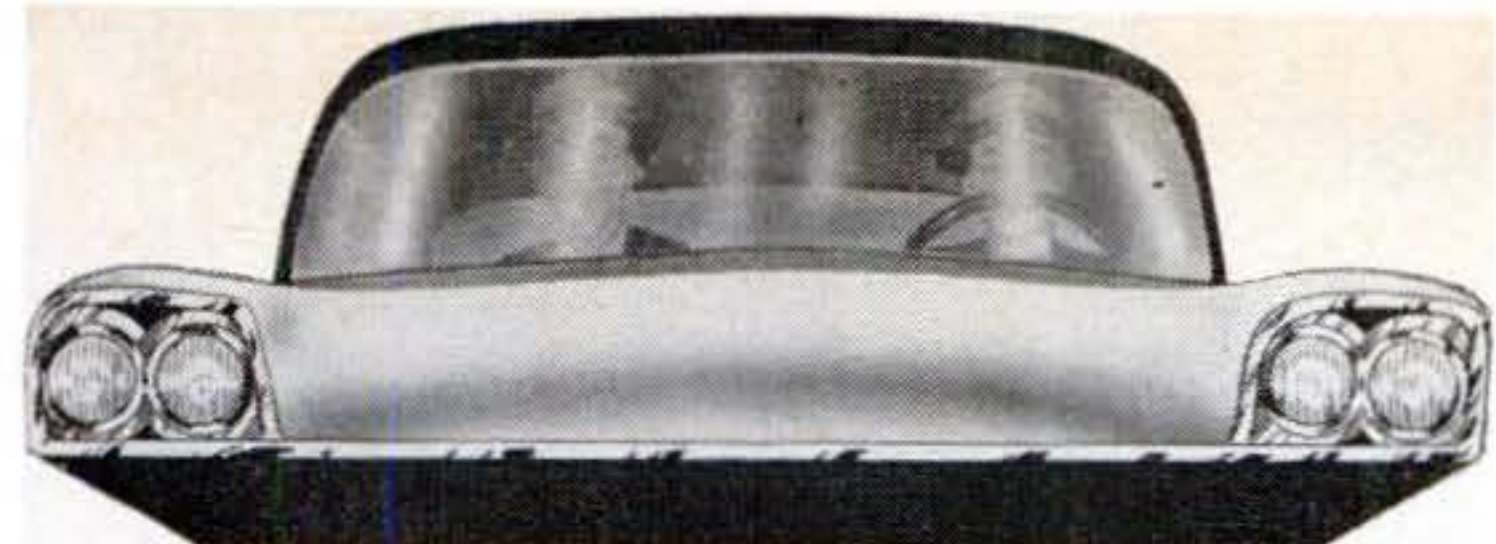

WANT LOW COST AIR RIDE?



**Four AIR LIFT Units
Cost Less Than Weekend Trip!**

Enjoy the bump and vibration-free luxury of the most expensive air suspensions — at a fraction of the cost! Air Lift Spring Controls are air inflatable butyl rubber cylinders — designed to control, cushion and stabilize the action of both FRONT and REAR spring suspensions by regulated air pressure. FRONT Air Lift units give improved roadability, prevent spring sag and contribute to SAFER DRIVING. REAR Air Lift units efficiently absorb 1000 pound overloads. Over a million sets in use.



FREE—reprint of **SPEED AGE** article, How to Ride on Air for \$25. Write Dept. 133.

AIR LIFT COMPANY

Lansing, Mich. In Canada: 18 Hook Ave. — Toronto 9, Ontario



THIS new book is a treasure-house of 15 complete projects by Bill Baker, nationally known designer and furniture maker. How to Make Your Own Built-ins and Space Savers has 160 large-size pages, 560 step-by-step photos, easy-to-follow instructions, exploded views and diagrams. Built-in units cover a wide range including: a luxury kitchen; hideaway bar; TV-Hi-Fi unit; woman's dream sewing center; and one-wall complete workshop. Plus a wealth of techniques for indirect lighting, finishing, panelling, many more!

Order your copies now on coupon below. **\$1.00**

Popular Science Publishing Co.

353 Fourth Ave. New York 10, N.Y.

B-1P758

Rush me _____ copies of How to Make Your Own Built-ins and Space Savers, by Bill Baker, at \$1.00 each. I enclose \$_____.

Books may be returned for prompt refund, if I'm not completely satisfied.

*Avoid Post Office delay. Include zone number, if any.

Name _____

Address _____

City _____ *Zone _____ State _____

SAVE 1/2 OR MORE

Build this six transistor

portable radio

\$34.95

No other portable gives you so many features at such a low price: 4" x 6" speaker, 500 to 1,000 hr. battery life, unbreakable plastic cabinet, plus high quality, all-transistor circuit.



IT'S EASY, FUN, EDUCATIONAL

No special tools or skills required. Clearly illustrated step-by-step instructions guarantee your success—and you learn about electronics the easy way—BY DOING!

SEND FOR FREE CATALOG

..... Describing nearly 100 other "do-it-yourself" HEATHKITS for hobby, hi-fi, ham radio or professional.



HEATH COMPANY

pioneer in "do-it-yourself" electronics

BENTON HARBOR 16, MICH.

a subsidiary of Daystrom, Inc.

name _____

address _____

city & state _____

RETAIL PRICE \$125.00

FACTORY TO YOU \$79.95

SUPERSHOP includes precision-built 8" tilting table saw, vertical and horizontal drill press, 30" lathe, sander, grinder. 100% BALL BEARING. Write for FREE catalog, full details, trial plan.

POWER TOOLS, INC.

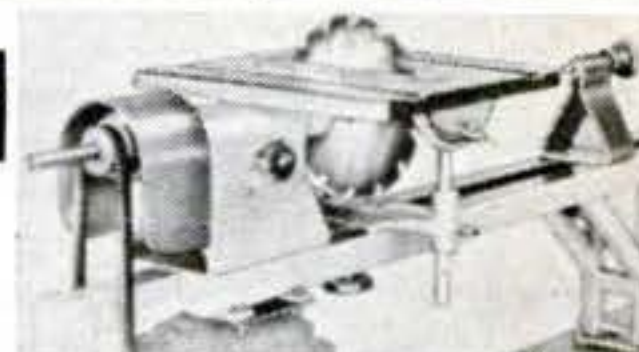

209 YATES AVE.
BELOIT, WISC.

KEEP COOL at Amazingly low cost!

Save up to **75%**

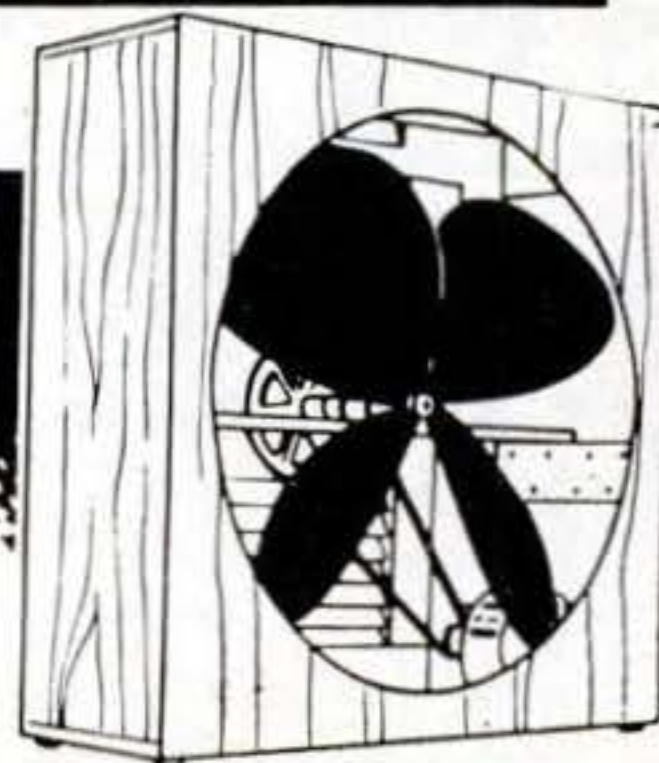

FAN KITS

EASY TO ASSEMBLE WINDOW or ATTIC FAN

No special tools or skill required. Thousands in use! Step-by-step instructions with kit. For standard or horizontal installation. Only a few pieces of lumber and new or used 1/4 HP motor needed to complete. Sold direct by manufacturer. Shipped anywhere in the world.

You get COMPLETE KIT

- Aluminum fan spider
- Masonite blades
- Shaft
- bronze bearings (Ball bearings available, \$4 extra per kit)
- Collars
- Pulleys
- Belts and bolts.

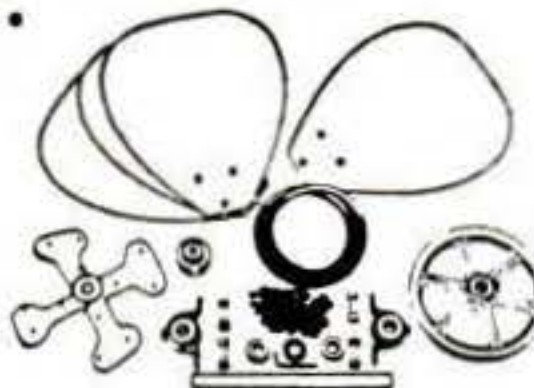

30" Fan cools average home (6000 CFM).... \$14.95
36" Fan cools larger homes (8000 CFM).... 17.95
24" Fan cools smaller home (4500 CFM).... 13.95
20" Fan cools apt., Office, etc. (2800 CFM).. 12.95

SATISFACTION GUARANTEED. Money order or check with order shipped postpaid. \$3.00 deposit on C.O.D. orders. Circular free. U.S. and foreign dealers wanted.

FAN KIT COMPANY 154-T NO. BELVEDERE MEMPHIS, TENNESSEE

JULY 1958 219

THE CONTINENTAL DISAPPEARING CLOTHESLINE

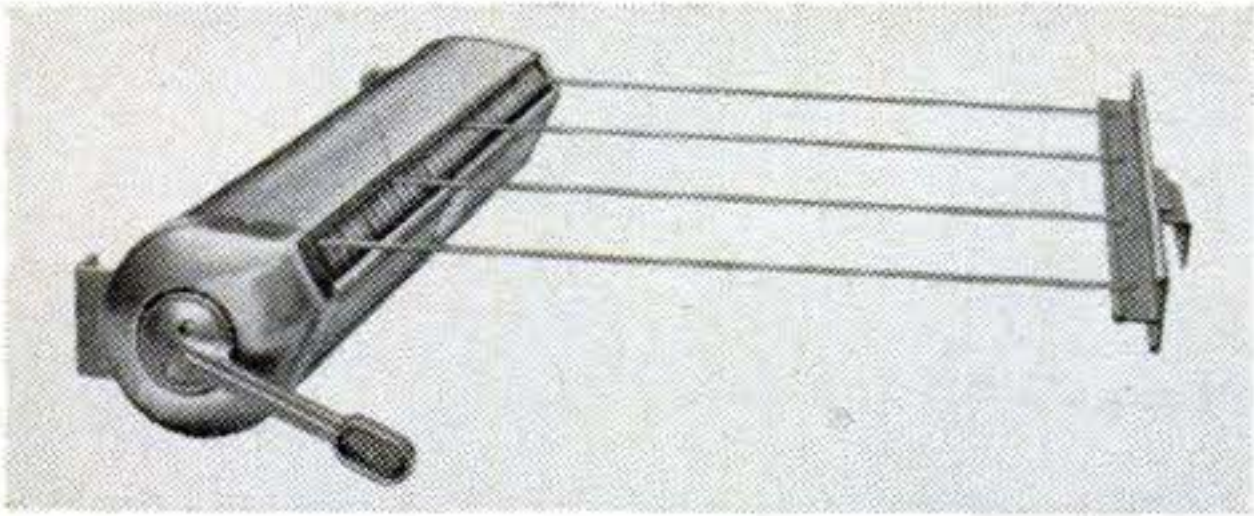

**CONVERTS YOUR DRYING YARD
INTO A PATIO, PLAY-YARD, GARDEN**



CONTINENTAL
disappearing
clothesline

See your hardware or
department store today.
Free folder on request.
Continental, 802 West
Whittier Blvd., Dept. PS
Whittier, California.

GOVERNMENT OIL LEASES LOW AS \$1 PER ACRE.

You do no drilling, pay no taxes, may realize a king-size profit without ever leaving home. Write for free map and literature.

AMERICAN OIL SCOUTS, Dept. PS
7321 Beverly Blvd. Los Angeles 36, Calif.

U-MAK-IT BOAT KITS



30 years of boat
kit pioneering. 30
models. Prams, Row-
boats, Outboards,
Cabin Cruisers and Skiffs.

SEND FOR ILLUS. CATALOG

Showing all models from 8' to 23'.
Const. details, paints, access., etc. All
you need to build your own.

MAIL 35c (coin) for Postage & Handling.

NEW LAPSTRAKE SKIFF KITS

Now added to our
great line of kits,
new easy to as-
semble Lapstrake
Skiffs.



U-MAK-IT products

DELAND, FLORIDA, DEPT. 11

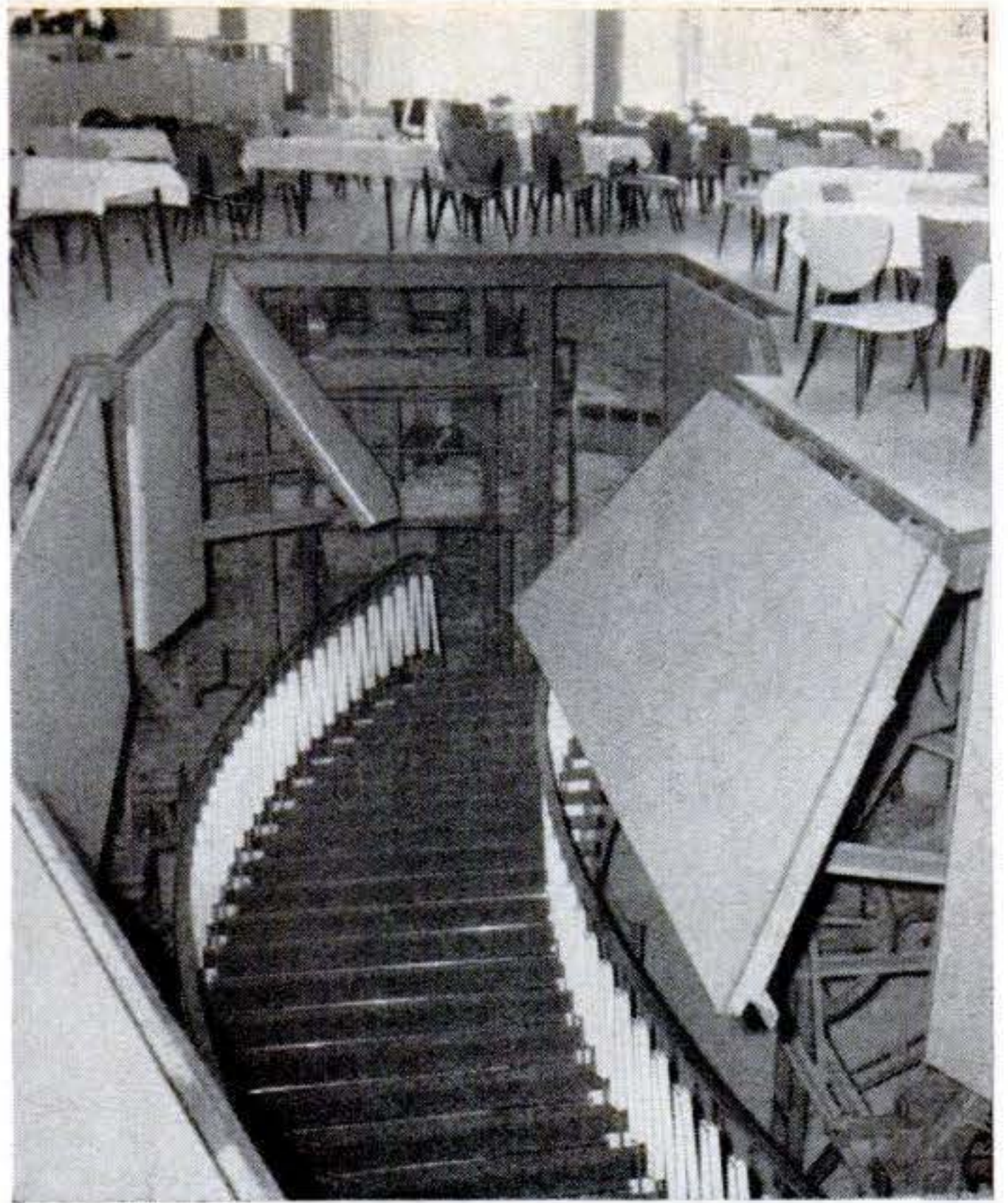

Stairway goes into hiding

STAIRS that disappear into the base-
ment to make way for a stage show are
one of the features of a new restaurant in
West Berlin. Operated by 13 motors, they
can be made to vanish in three minutes.

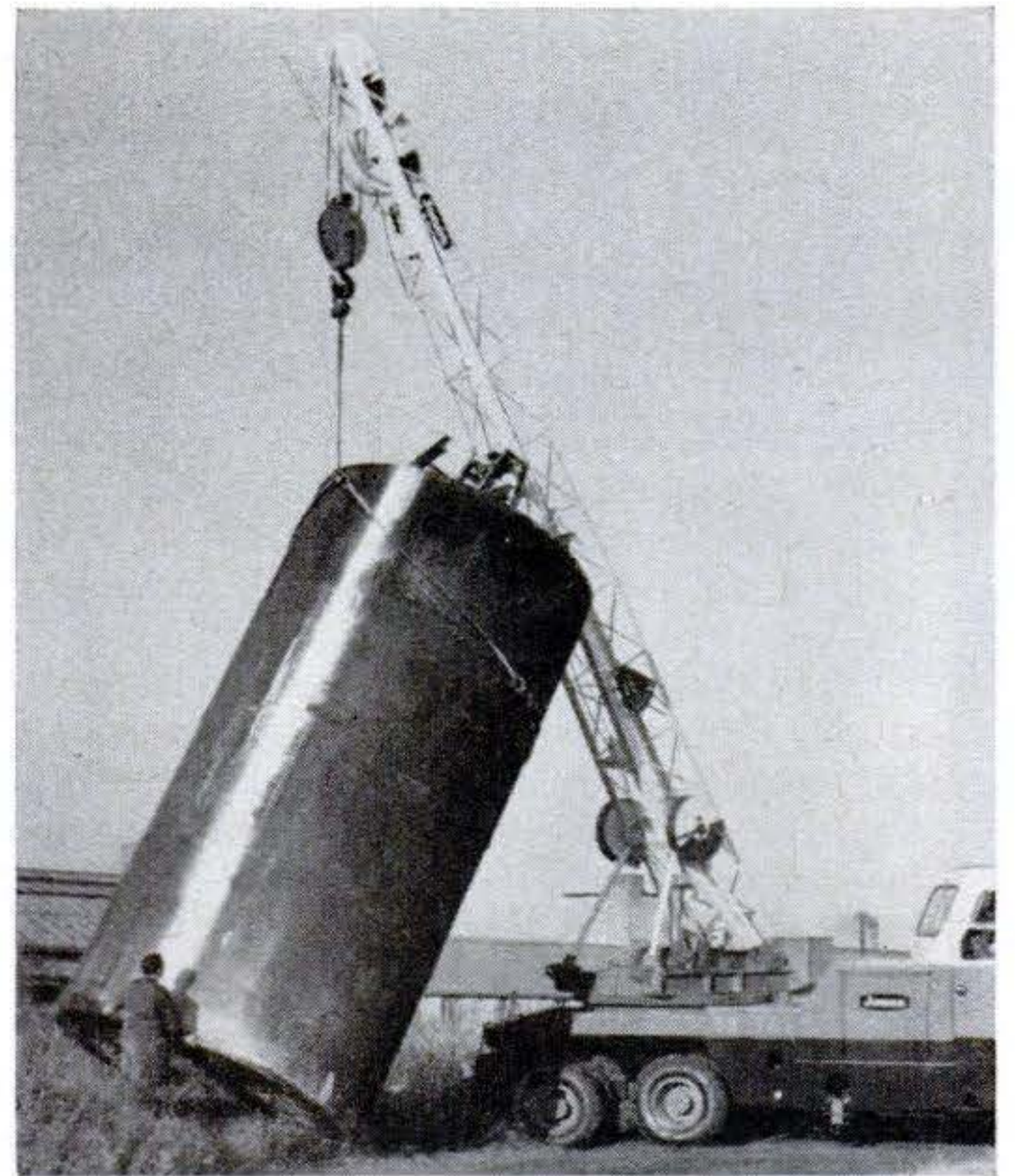

Mobile crane can lift 10 tons

GREAT lifting power and high road
speed are claimed for this new British
crane shown hoisting a boiler. Powered by
a heavy-duty diesel, it lifts 10 tons and
swings through 360 degrees.

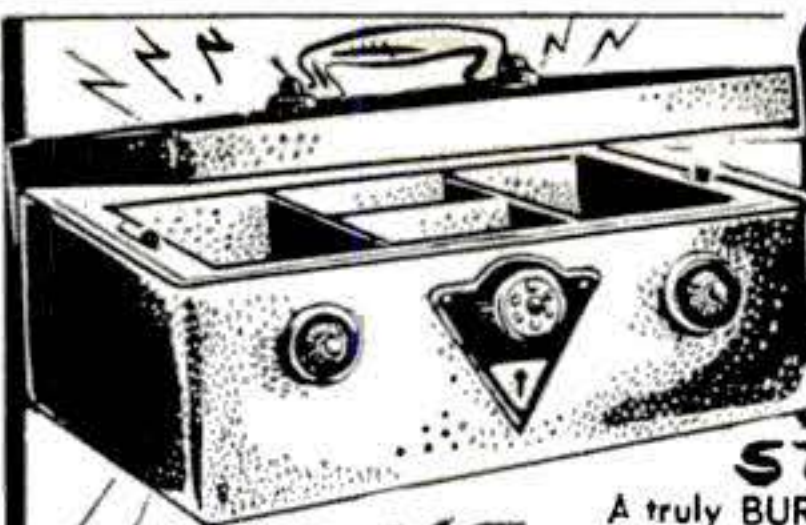

AMAZING - NEW !!
Portable Steel
CASH BOX
WITH
ALARM

STRONG - SAFE

A truly BURGLAR-PROOF Cash Box! Has a built-in bell alarm as well as two combination locks and a key type lock. When unlocked cover opens automatically by turning knob in center. If the alarm is on it will ring as soon as the box is moved or the cover opened, and will continue to ring until shut off. Heavy duty steel construction with removable cash tray. 10" deep x 6-1/8" high x 14-1/4" wide. An IMPORT BARGAIN!

RING
RING
For HOME
OFFICE
or SHOP

**NOW
1688**



**TWO SPEED
HOIST**
Now **3295**

Rated at 3000 lbs. lift. Has gear driven two-speed Drum - one speed direct drive the other through gears at 8 to 3 ratio. Drum holds 400 ft., 3/8" cable; 600 ft., 1/4" cable or 3000 ft., 1/8" cable. Has built-in brake with ratchet lever.



**100% NYLON U.S.A.F.
COVERALLS**
Now Only **488**

Newly released by Air Corps. 100% NYLON in Air Corps Blue. Has six pockets with zipper closures. Adjustable waist. Sleeve pencil pocket. Full front zipper and ankle zipper. Sizes: 30 through 42. Excellent condition.

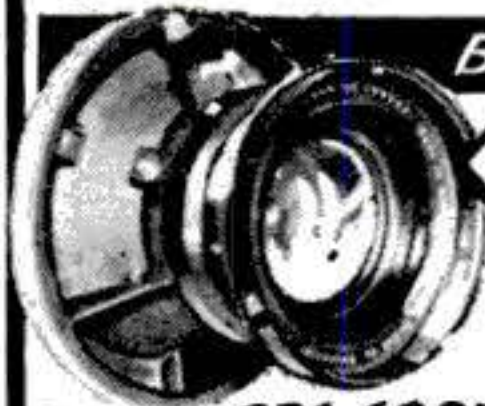

BUILD A SATELLITE CAMERA

7"-f2.5 EASTMAN AERO LENS

Of the first four photos of the Russian Sputniks, three were shot by a U.C.L.A. Student with this lens in a home made camera. We furnish these plans FREE to adapt the lens. It has a 178mm focal length with stops from f/2.5 to f/16. Also makes an excellent telephoto lens when used on 35mm or Speed Graphic Cameras. Glass is coated and fully color corrected.

Cost Gov't **REG. 69.95**
approx. **Now 39.95**
\$200



3 POWER TANK TELESCOPE

Made of sturdy brass and steel. Contains a Kellner eyepiece, reticle, 2 achromatic erector lenses, 1 achromatic objective lens (25mm diam.) with all optics coated. Length 22-1/2". Field 12°, 19 feet. **SAVE!**

3X ONLY 488



**8-POWER
ELBOW TELESCOPE**
Now **988** 7500 VALUE

Has big 2" objective - Kellner eyepiece - Amici erecting prism - internal illumination for sharp detail of cross-hair reticle. Has three built-in filters, neutral, red & amber. Field 325 ft. at 1000 yds. Eyepiece alone worth \$12.50

palley's

2263 east vernon ave. dept. PS-78
los angeles 58, calif.

TERMS: Send check or M.O. 1/2 dep. with C.O.D.'s. All items F.O.B. Calif. whse, Calif. residence add 4% tax.

**AMAZING 396-PAGE
CATALOG**

Thousands of items of all descriptions. Hand & Power Tools, Industrial & Building Materials, Micro & Telescopes, Hydraulic Equip. of all types. Send 50¢ TODAY for handling & mailing. Your money refunded with 1st order.



**NEW 40X
TELESCOPE**

New Import! Complete with its own sturdy metal tripod. Has high luminosity 40 power eye piece with large 60mm coated objective lens. Ideal for spotting hits on rifle range or for spotting 'SPUTNIKS'. **SAVE!**

4995

**PHILIPPINE MAHOGANY
PLYWOOD**

Both sides sanded. Bonded with finest resin adhesive. Face side unjointed. All shipments at lowest truck rates. Panel Dens, Office, Home, etc. Over 6 million feet shipped by us.

**SAVE
50%**

**BUY
FROM IMPORTER**

**3MM (1/8") X
3 FT. X 6 FT.
\$500 VALUE - PER SHEET
MINIMUM ORDER 8 SHEETS**

**FREE
SAMPLE
ON
REQUEST**

**1/4" X 4 FT. X 8 FT.
950 VAL.
MIN. ORDER
4 SHEETS**

**449
PER SHEET**



**SAVE 60% ON TRANSLUCENT
FIBERGLAS PANELS**

Finest quality. Available in many widths and lengths. Full color selection. Send for FREE Sample and Booklet. 85¢ sq. ft. value NOW at our special National BUY NOW PRICE of...

**NOW
39¢
SQ. FT.**

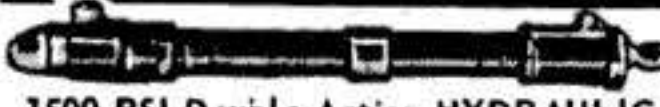

CATALOG No. H-14

1500 PSI Double Action HYDRAULIC CYLINDER - Has bore of 1-3/8"; Shaft 1" diameter, Stroke 15-5/8", O/A lgh. 22". Cost Gov't approx. \$90.

795



CATALOG No. H-84

1500 PSI Double Action HYDRAULIC CYLINDER BARGAIN - Has 1-1/2" Bore, 9/16" Shaft, adjustable stroke of 1-3/16" to 4-3/8", O/A length 14-1/2". Approx. gov't cost \$68.00. NOW ONLY...

395



**NEW HYDRAULIC
HAND PUMP**
HP-3 **695**

Operates at 1500 PSI. Displaces 0.19 GPM at 30 cycles per minute. Capacity 1.5 cubic inches per cycle. Has built-in check valve. Cost gov't approx. \$80.00

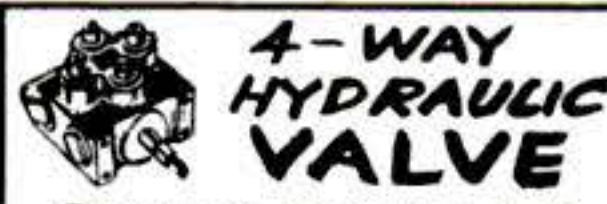

**4-WAY
HYDRAULIC
VALVE**

Poppet type. Spring loaded. Pressure balanced. Off in neutral. Has 1/4" internal tube ports. Cost Gov't approx. \$30.00 H-V7A-1 **395**



**CENTRIFUGAL
WATER
PUMP**

Ideal for draining basements, sumps, flooded areas. Must be primed. Has brass body and rotor. Stainless steel shaft, Bearing mounted. 1-1/2" pipe thread inlet, 1-3/4" hose outlet. Delivers 6000 GPH at 1 ft. head at 1800 RPM with a 1/3 HP motor. **1995**



**NEW SURPLUS
GYRO**
NEW LOW PRICE **888**

Turns up to 50,000 RPM. Electric-drive motor is integral with balance wheel. Has ball bearing mounts on either side for precision mounting. Balance wheel is fully ball bearing mounted. Operates on 24V, AC current. A remarkable value for Science Lab, experimental work, hobbyist, etc. Originally used in Aircraft Auto Gyro

MOUNT BASE for above pump \$4.25
1-1/4" Bronze Foot VALVE for above pump to hold prime & filter. \$3.98



4-SPEED HOBBY MOTOR

A rugged, precision built electric motor for use on Barbecue, in home workshop, etc. Uses 110 Volt, 60 cycle current. Has four take-off shafts turning at different speeds - 5, 25, 150 and 4000 RPM. **Now 888**

Crosley 115V, 60 Cycle AC AIR COMPRESSOR - Adjusts to 45 PSI pressure. ONLY \$16.95

OXYGEN/AIR HOSE - 250 PSI with 1/4" fittings. 25' - \$2.25; 50' - \$4.00; 100' - \$7.15

BULK HOSE without fittings
COOLANT - Alcohol, gas, oil, water, etc.
1/2", lgh 66" - \$22¢ ft. - 1", lgh. 10' - \$31¢ ft.
1-1/4" - 10' lgh. - \$40¢ ft.

AEROQUIP Size -10, 1500 PSI. Uses standard 1/2" bayonet fittings. 5/8" OD. In 20 to 50 ft. lengths. 27¢ per ft.

R-1 GENERATOR
- Designed for use in Aircraft. Easily converted for use as Arc Welder, Battery Charger, Electro Plating, etc. 300 A, 24-32V. DC. **1695**
FREE conversion instructions.

Welding REACTOR-400 Amp \$10.95

"V" BELT Pulley Adaptor. \$27.50

24V RHEOSTAT for welder. \$2.95

Throttle Control SOLENOID. \$7.95

**CHOICE
ARMY COLT
.45 AUTOMATICS!**



\$10 deposit

SPECIAL REDUCED PRICE!

The finest single lot of the authentic powerful U.S. Army Model .45 Colt Automatics we have ever seen! Due to a very favorable purchase we are able to place these on the market at \$10 under any other offering of similar quality we have seen in 10 years. Inside, exterior and bores guaranteed very good to excellent. Ammo at all gun stores.

.45 Colt Auto, (X14C) Very Good to Ex. \$34.95
.45 Colt Auto, (X14D) Mint Cond. \$39.95

TO ORDER: Send \$10 deposit, pay balance C.O.D., shipped F.O.B. Pasadena. 10 day money back guarantee. Test fire if you wish. Enclose signed statement: "I am not an alien, never convicted crime of violence, am not under indictment or fugitive, am 21 or over." Mass., Mo., Mich., N.Y., N.J., N.C., R.I., Omaha, N. Orleans require permits. Enclose with order. Calif. resid. order through local dealer only.

GOLDEN STATE ARMS CORP.

386 W. Green Street, Pasadena 64, Calif.

HOW TO PROTECT YOUR INCOME!
Earn Extra Money With A Rapid

**SHEAR SHARPENER
AND
KNIFE SERRATOR**

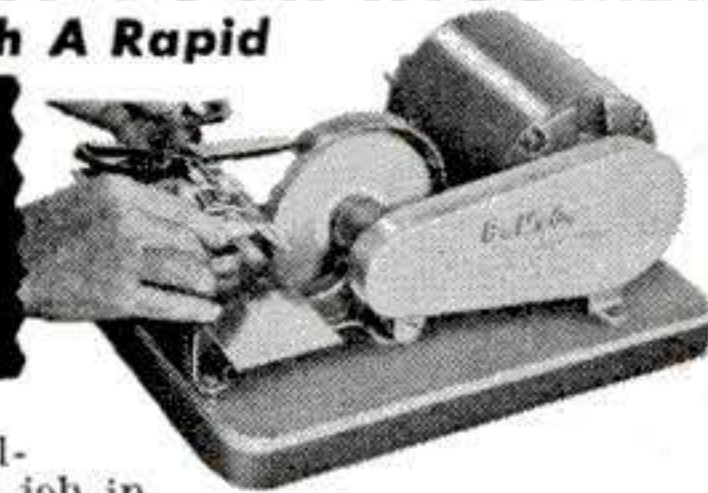

Easy to operate - professional-type sharpener does a perfect job in just 2 minutes on all types scissors and shears, including pinking shears. Knife guide puts proper edge on any blade. Knife serrating attachment puts saw-tooth edge on hard or soft steel blades. Quick profits from homes, dressmakers, barbers, restaurants, hotels, butchers, etc. No experience needed. Big opportunities with this precision ball bearing machine. Has 3/4 h.p. motor. A money-making investment - write for FREE FOLDER PS-7

BEAVER MFG. CO P.O. BOX 434, 800 So. Isis Ave. Inglewood, Calif.

Special Bonus!

Save
\$66.67
on This Lathe

**Up to \$66.67 of Accessories FREE
With South Bend 10-K Lathe**

BUY THIS

Model A 10-K Lathe
Toolroom 10-K Lathe
Model B 10-K Lathe

GET THIS FREE

\$66.67 Accessory Assortment A
\$66.67 Accessory Assortment A
\$58.20 Accessory Assortment B

Model C 10-K Lathes come with a \$50.55 Assortment.

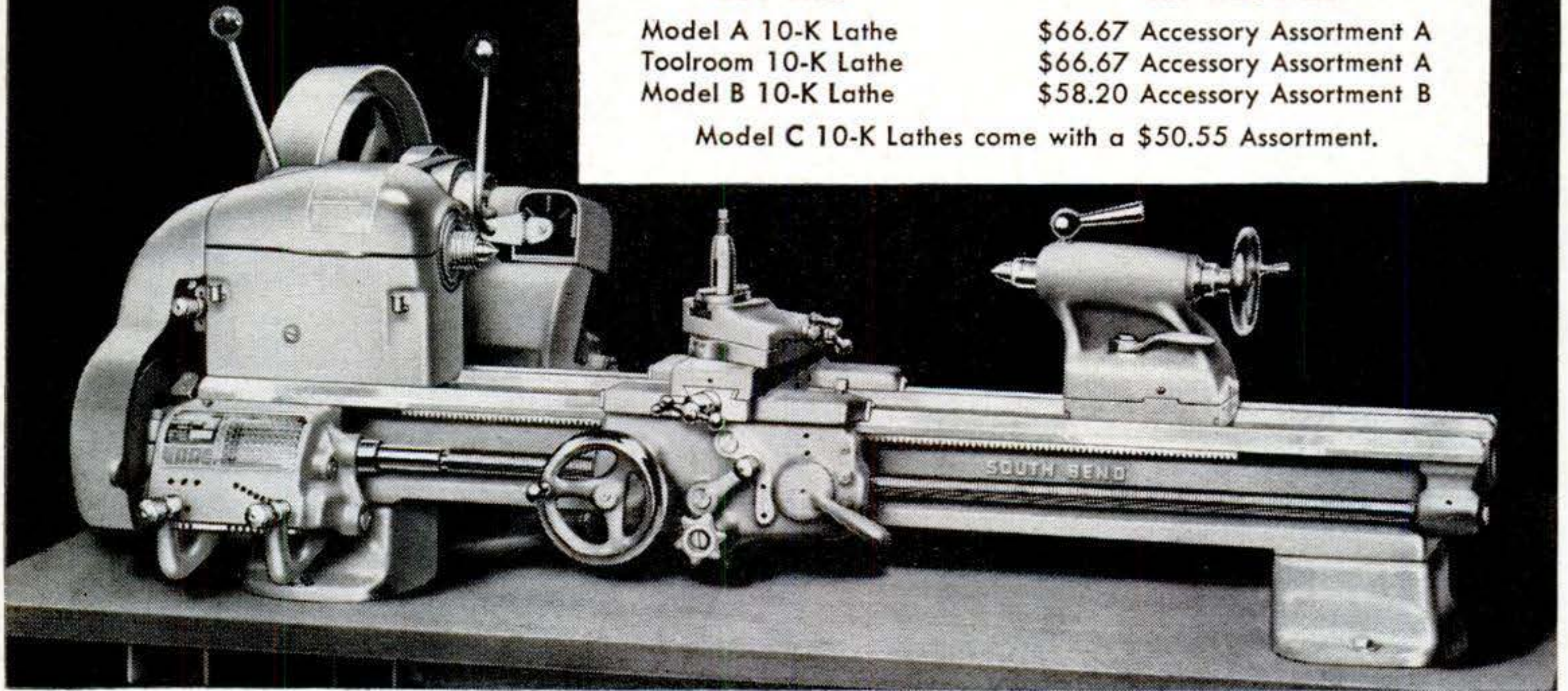

Here's your chance to get a fine South Bend 10" Precision Lathe *plus* a big assortment of essential lathe accessories *without extra charge*. Choose from 68 models and sizes for all your production, toolroom, maintenance and experimental needs. This is the first time such an offer has been made—but it ends August 31st—so act quickly. Mail the coupon now.

Model A 10-K Lathe illustrated. Model B Lathes have independent change gears instead of gear box. Model C Lathes have independent change gears and plain apron.

Accessory Assortment A

10 in 1 Tool Holder.....\$14.70
Face Plate Chuck..... 19.50
Set 21 Drills, 1/16" to 3/8"..... 11.97
Thread Indicator Dial..... 10.95
3 Dogs—1/2", 1", 1 1/2"..... 4.60
Knock-out Bar..... 1.65
Cutter Bits..... 3.30
Total.....\$66.67

Accessory Assortment B

10 in 1 Tool Holder.....\$14.70
Face Plate Chuck..... 19.50
Thread Indicator Dial..... 10.95
Knock-out Bar..... 1.65
Cutter Bits..... 3.30
Center Drill Holder..... 3.50
3 Dogs—1/2", 1", 1 1/2"..... 4.60
Total.....\$58.20

No substitutions, returns or exchanges.

10-K LATHES

12-SPEED HORIZONTAL MOTOR DRIVE

Catalog Number	Model	Bed Length	Price
CL653Z	C	3 1/2'	\$412
CL653A	C	4'	436
CL653R	C	4 1/2'	470
CL667Z	B	3 1/2'	487
CL667A	B	4'	511
CL667R	B	4 1/2'	545
CL670Z	A	3 1/2'	570
CL670A	A	4'	594
CL670R	A	4 1/2'	628
CL8670Z	Toolroom	3 1/2'	800
CL8670A	Toolroom	4'	824

Also available with 16-speed V-belt drive, and with Metal Column Base or Self-Contained Motor Drive. Prices f.o.b. factory, less electrical equipment.

South Bend Lathe, South Bend 22, Indiana

Please send literature on 10-K Lathe Special Offer—also name of nearest distributor.

Send complete Time Payment information.

Name _____

Street _____

City, Zone _____ State _____

(Offer limited to continental U. S. and expires August 31, 1958)

SOUTH BEND LATHE

SOUTH BEND 22, INDIANA

Builders of Lathes, Milling Machines,
Shapers, Drill Presses, Pedestal Grinders



Up to 24
months to pay.

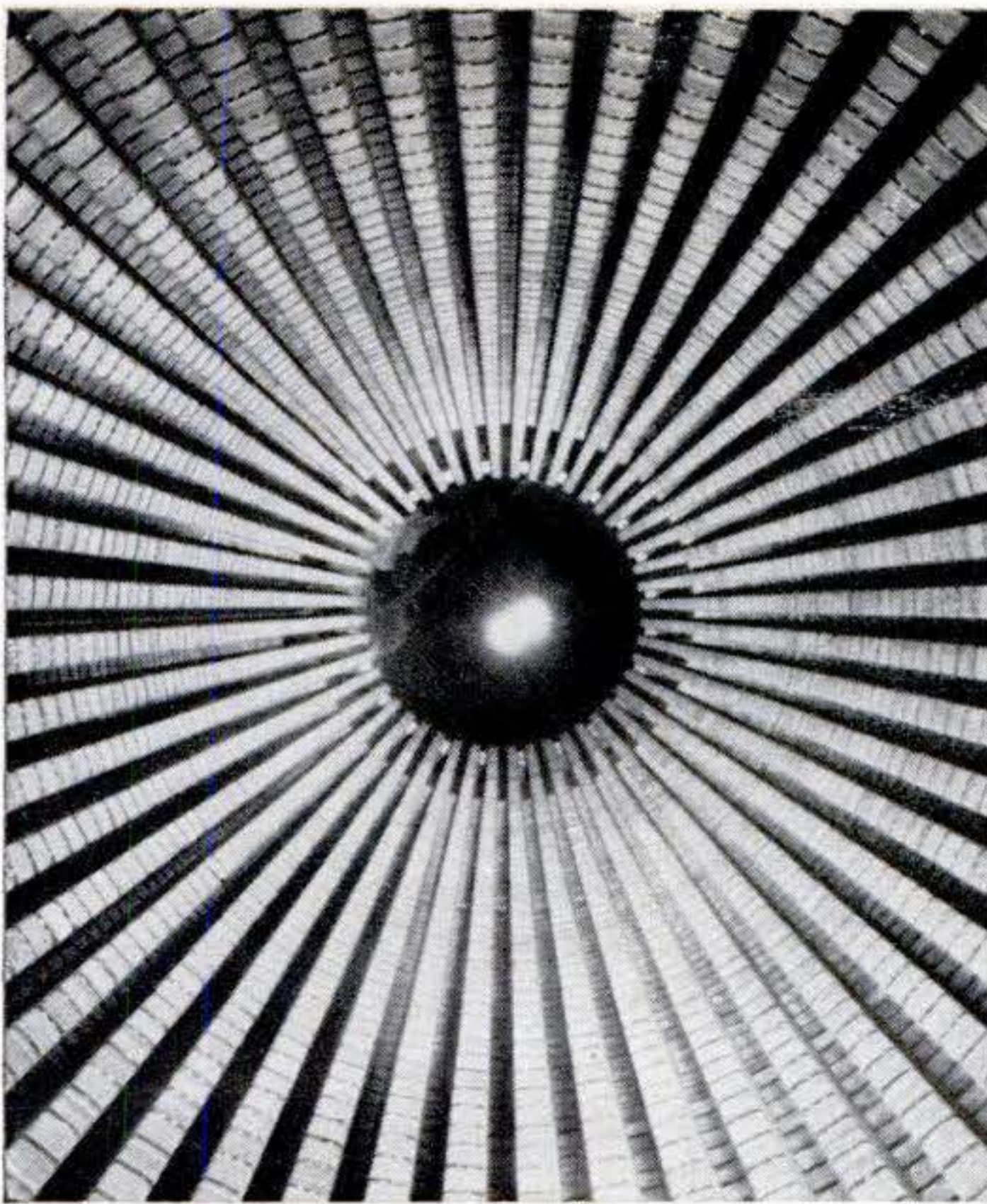

Big stator goes into generator

THIS 28-foot stator, seen from below, weighs 430,000 pounds, and is made of 200,000 stacked steel punchings. It's for a GE generator to produce 156,250 kilowatts. The bright spot is an overhead light.

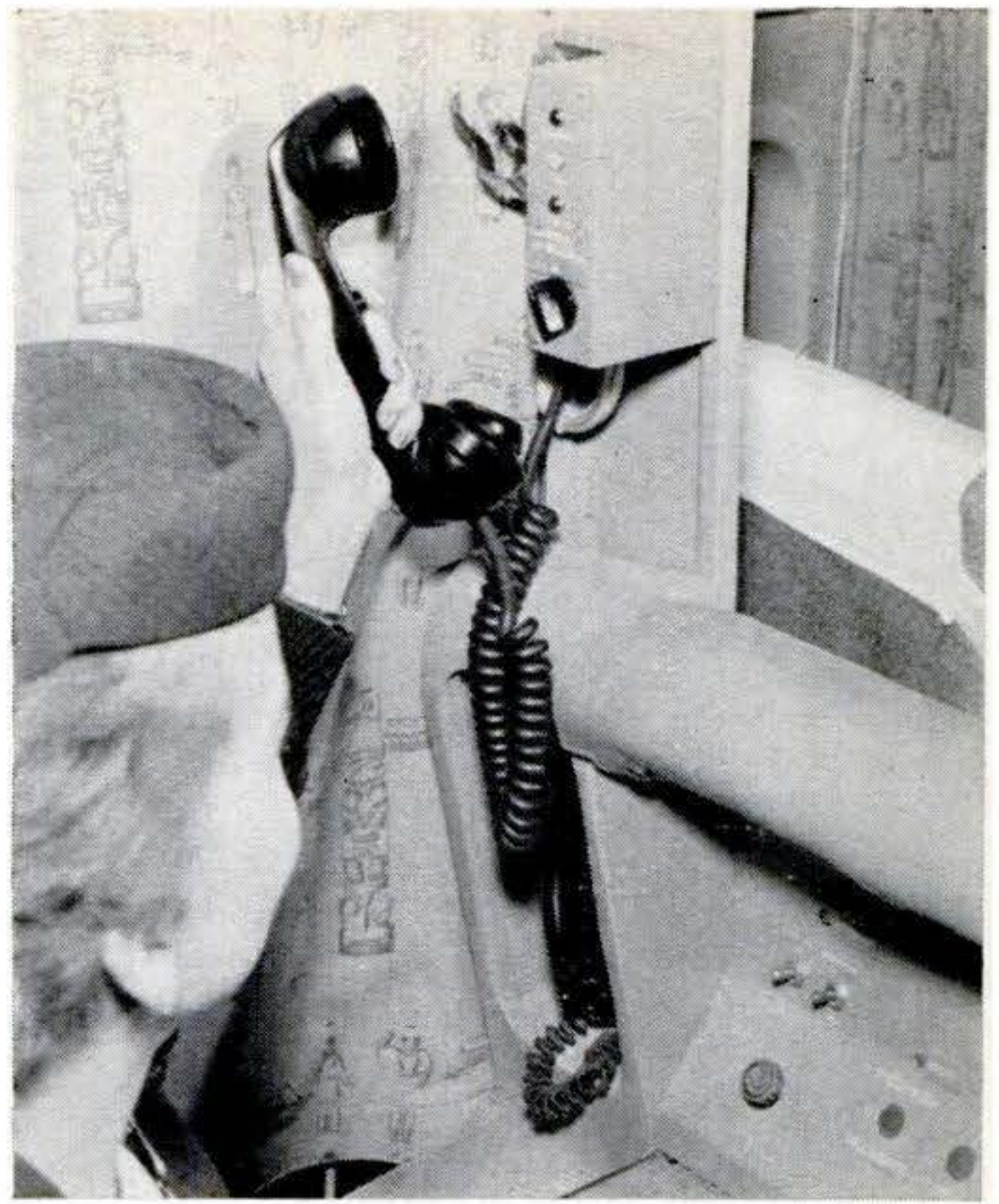

Sky phone talks to ground

You soon may be able to call home from the air. This radio telephone being used by an airline stewardess has been installed in a Northwest Orient Stratocruiser for testing and to check public reaction.



Liquids dropped from plane

THE saucer-shaped rubber bag at right was developed for the Army for air-to-ground delivery of water, liquid foods and gasoline to troops. Each container holds five gallons, has handles in its skirt.



Photo drone makes own light

THIS low-flying camera drone is designed to take close-ups of enemy installations at night. It fires flares at intervals for flash sequences on a moving film roll. Exposures are timed to overlap.

FOR REAL JOB SECURITY —GET AN I.C.S. DIPLOMA



"You can stop worrying, Jane. My job's secure now! And here's the insurance policy to prove it—my I.C.S. diploma!"

This feeling of security is probably typical of every I.C.S. graduate. Because—as the job situation gets tighter, the man with I.C.S. training has the advantage.

Why? Your I.C.S. diploma tells your present employer three important things: (1) You want to make the most of your present job.

(2) You have the training you need for advancement. (3) You look for better ways of doing things *on your own*.

What you do about your future is up to *you*. Do nothing and stay at your present job at the same old pay. Or earn an I.C.S. diploma in your spare time for *security, promotions, more pay!* Your first step is to mark the course that interests you in the coupon below, and mail it to us.

Three Free Books

We'll send you three interesting books. The first, "How to Succeed," is a gold mine of helpful tips. Points out many small things in your personality and behavior that can make the difference between success and failure. The second tells about the opportunities in the field of your choice. The third is a sample lesson (Math).

Costs pennies a day

Many an I.C.S. student has made up the cost of his course in one month with the salary increase his I.C.S. training earned for him. By studying at home in your spare time, you pay yourself many times an hour more than you're now making. (One student reports—"My I.C.S. course was worth \$95 an hour to me.")

The security of your present job—or success in finding the new job you've always wanted—is in *your hands*. Move ahead with I. C. S. training while others stay behind on the routine, small-pay jobs.

Remember, your first step to security is to mail this coupon. Take a few minutes and do it *now*. If you put it off, it can cost you your future.

For Real Job Security—Get an I. C. S. Diploma! I. C. S., Scranton 15, Penna. Accredited Member, National Home Study Council

INTERNATIONAL CORRESPONDENCE SCHOOLS



BOX 81314G, SCRANTON 15, PENNA.

(Partial list of 257 courses)

Without cost or obligation, send me "HOW to SUCCEED" and the opportunity booklet about the field BEFORE which I have marked X (plus sample lesson):

- | | | | | |
|--|--|--|--|---|
| <p>ARCHITECTURE and BUILDING CONSTRUCTION</p> <ul style="list-style-type: none"> <input type="checkbox"/> Air Conditioning <input type="checkbox"/> Architecture <input type="checkbox"/> Arch. Drawing and Designing <input type="checkbox"/> Building Contractor <input type="checkbox"/> Building Estimator <input type="checkbox"/> Carpentry and Millwork <input type="checkbox"/> Carpenter Foreman <input type="checkbox"/> Heating <input type="checkbox"/> Interior Decoration <input type="checkbox"/> Painting Contractor <input type="checkbox"/> Plumbing <input type="checkbox"/> Reading Arch. Blueprints <p>ART</p> <ul style="list-style-type: none"> <input type="checkbox"/> Commercial Art <input type="checkbox"/> Magazine & Book Illus. <input type="checkbox"/> Show Card and Sign Lettering <input type="checkbox"/> Sketching and Painting <p>AUTOMOTIVE</p> <ul style="list-style-type: none"> <input type="checkbox"/> Automobiles <input type="checkbox"/> Auto Body Rebuilding and Refinishing <input type="checkbox"/> Auto Engine Tuneup <input type="checkbox"/> Auto Technician | <p>AVIATION</p> <ul style="list-style-type: none"> <input type="checkbox"/> Aero-Engineering Technology <input type="checkbox"/> Aircraft & Engine Mechanic <p>BUSINESS</p> <ul style="list-style-type: none"> <input type="checkbox"/> Accounting <input type="checkbox"/> Advertising <input type="checkbox"/> Business Administration <input type="checkbox"/> Business Management <input type="checkbox"/> Cost Accounting <input type="checkbox"/> Creative Salesmanship <input type="checkbox"/> Managing a Small Business <input type="checkbox"/> Professional Secretary <input type="checkbox"/> Public Accounting <input type="checkbox"/> Purchasing Agent <input type="checkbox"/> Salesmanship <input type="checkbox"/> Salesmanship and Management <input type="checkbox"/> Traffic Management <p>CHEMICAL</p> <ul style="list-style-type: none"> <input type="checkbox"/> Analytical Chemistry <input type="checkbox"/> Chemical Engineering <input type="checkbox"/> Chem. Lab. Technician <input type="checkbox"/> Elements of Nuclear Energy <input type="checkbox"/> General Chemistry <input type="checkbox"/> Natural Gas Prod. and Trans. <input type="checkbox"/> Petroleum Prod. and Engr. <input type="checkbox"/> Professional Engineer (Chem) <input type="checkbox"/> Pulp and Paper Making | <p>CIVIL ENGINEERING</p> <ul style="list-style-type: none"> <input type="checkbox"/> Civil Engineering <input type="checkbox"/> Construction Engineering <input type="checkbox"/> Highway Engineering <input type="checkbox"/> Professional Engineer (Civil) <input type="checkbox"/> Reading Struc. Blueprints <input type="checkbox"/> Structural Engineering <input type="checkbox"/> Surveying and Mapping <p>DRAFTING</p> <ul style="list-style-type: none"> <input type="checkbox"/> Aircraft Drafting <input type="checkbox"/> Architectural Drafting <input type="checkbox"/> Drafting Machine Design <input type="checkbox"/> Electrical Drafting <input type="checkbox"/> Mechanical Drafting <input type="checkbox"/> Sheet Metal Drafting <input type="checkbox"/> Structural Drafting <p>ELECTRICAL</p> <ul style="list-style-type: none"> <input type="checkbox"/> Electrical Engineering <input type="checkbox"/> Elec. Engr. Technician <input type="checkbox"/> Elec. Light and Power <input type="checkbox"/> Practical Electrician <input type="checkbox"/> Practical Lineman <input type="checkbox"/> Professional Engineer (Elec) <p>HIGH SCHOOL</p> <ul style="list-style-type: none"> <input type="checkbox"/> High School Diploma | <ul style="list-style-type: none"> <input type="checkbox"/> Good English <input type="checkbox"/> High School Mathematics <input type="checkbox"/> Short Story Writing <p>LEADERSHIP</p> <ul style="list-style-type: none"> <input type="checkbox"/> Industrial Foremanship <input type="checkbox"/> Industrial Supervision <input type="checkbox"/> Personnel-Labor Relations <input type="checkbox"/> Supervision <p>MECHANICAL and SHOP</p> <ul style="list-style-type: none"> <input type="checkbox"/> Diesel Engines <input type="checkbox"/> Gas-Elec. Welding <input type="checkbox"/> Industrial Engineering <input type="checkbox"/> Industrial Instrumentation <input type="checkbox"/> Industrial Metallurgy <input type="checkbox"/> Industrial Safety <input type="checkbox"/> Machine Design <input type="checkbox"/> Machine Shop Practice <input type="checkbox"/> Mechanical Engineering <input type="checkbox"/> Professional Engineer (Mech) <input type="checkbox"/> Quality Control <input type="checkbox"/> Reading Shop Blueprints <input type="checkbox"/> Refrigeration and Air Conditioning <input type="checkbox"/> Tool Design <input type="checkbox"/> Tool Making <p>RADIO, TELEVISION</p> <ul style="list-style-type: none"> <input type="checkbox"/> General Electronics Tech. | <ul style="list-style-type: none"> <input type="checkbox"/> Industrial Electronics <input type="checkbox"/> Practical Radio-TV Eng'g <input type="checkbox"/> Practical Telephony <input type="checkbox"/> Radio-TV Servicing <p>RAILROAD</p> <ul style="list-style-type: none"> <input type="checkbox"/> Car Inspector and Air Brake <input type="checkbox"/> Diesel Electrician <input type="checkbox"/> Diesel Engr. and Fireman <input type="checkbox"/> Diesel Locomotive <p>STEAM and DIESEL POWER</p> <ul style="list-style-type: none"> <input type="checkbox"/> Combustion Engineering <input type="checkbox"/> Power Plant Engineer <input type="checkbox"/> Stationary Diesel Engr. <input type="checkbox"/> Stationary Fireman <p>TEXTILE</p> <ul style="list-style-type: none"> <input type="checkbox"/> Carding and Spinning <input type="checkbox"/> Cotton Manufacture <input type="checkbox"/> Cotton Warping and Weaving <input type="checkbox"/> Loom Fixing Technician <input type="checkbox"/> Textile Designing <input type="checkbox"/> Textile Finishing & Dyeing <input type="checkbox"/> Throwing <input type="checkbox"/> Warping and Weaving <input type="checkbox"/> Worsted Manufacturing |
|--|--|--|--|---|

Name _____ Age _____ Home Address _____

City _____ Zone _____ State _____ Working Hours _____ A.M. to P.M. _____

Occupation _____ Canadian residents send coupon to International Correspondence Schools, Canadian, Ltd., Montreal, Canada. . . . Special tuition rates to members of the U. S. Armed Forces.



Thunderbird-bred in beauty, brawn
and high-stepping performance

58  FORD

The first car ever to use the whole world as a test track

FORD DIVISION OF FORD MOTOR COMPANY

IMAGINE! The "Meat" of 176 Official Shop Manuals...in This One Giant Illustrated Repair Guide!

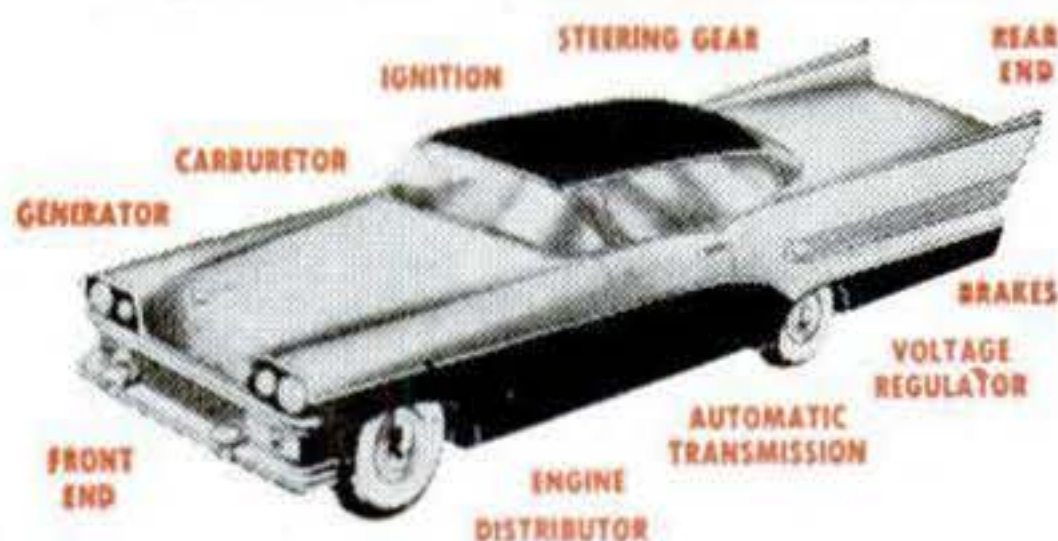

No wonder beginners and experts agree—
This is the Easy way to

FIX ANY PART OF ANY CAR

THERE'S one sure way to "lick" any auto repair job — and that's to get the advice of a real *expert*. That's why Motor's Auto Repair Manual is so widely used (over 2½ million copies sold!). It brings you the expert guidance of the engineers who made the cars and know them "inside out." Yes, packed into this giant volume is the "know how" from 176 OFFICIAL SHOP MANUALS, hundreds of factory bulletins, boiled down in easy-to-follow words and pictures.

Factory-tested procedures show how to fix any part of any popular make car — 1949 thru 1958. No guesswork! Manual "starts from scratch" — leads you through entire job with easy step-by-step directions, clear "how-to" pictures. You CAN'T go wrong.

OVER 1000 BIG PAGES — 2900 PICTURES

NEW, REVISED, ENLARGED Edition covers everything you need to know to repair over 600 different car models — including ALL 1958 CARS. Over ONE THOUSAND giant pages, 2,900 "This-is-How" pictures, 291 "Quick-Check" charts—23,436 essential repair specifications. Over 225,000 service and repair facts.

Not only do you get big separate illustrated sections covering every one of the 24 car makes — you also get detailed chapters on servicing car parts: Transmissions, Air Suspensions, Rear Ends, Generators and Regulators, Fuel

Pumps, Ignition Systems, Overdrives, Automatic Transmissions, Brakes, Valves, Pistons, Rings, Water Pumps, Distributors, Dash Gauges, Power Steering, Power Brakes, and more.

PLUS Factory Specifications and Adjustment Tables, Tune-Up Charts, etc. In addition, big TROUBLE-SHOOTING SECTION helps you spot any of 2,300 car troubles in a jiffy.

Try Book FREE 7 Days

SEND NO MONEY! Just mail coupon (paste it to a post card if you prefer.) Use the Manual for a whole week, *free*. If you don't agree that it is the greatest time-saver and work-saver you've ever seen — return book in 7 days and pay nothing. Mail coupon today! Address: **MOTOR Book Dept., Desk 2-G, 250 West 55th St., New York 19, N.Y.** (Schools, Bookstores: Write for discounts.)

FREE 7-DAY TRIAL

Return and Pay Nothing
If Not Delighted

Same FREE 7-Day Offer on MOTOR'S Brand-New TRUCK REPAIR MANUAL

Covers EVERY job on EVERY gasoline-powered truck made since 1949 — PLUS GM and Cummins Diesels. Over 2,000 illustrations; over 300,000 facts. Check proper box in coupon for FREE 7-DAY TRIAL.



Amazed Self and Friends — "I amazed myself and my friends, too. Now do jobs that stumped me before." — Michael Baliczky, Newark, N. J.

So Complete and Easy to Understand — "So complete, easy to understand — have done jobs with Manual I would not have attempted without it." — C. L. Vanerstrom, Mich.



Covers All Models — 1949 thru 1958

Buick	Jeep
Cadillac	Lincoln
Chevrolet	Mercury
Chrysler	Nash
Clipper	Oldsmobile
Continental	Packard
De Soto	Plymouth
Dodge	Pontiac
Edsel	Rambler
Ford	Studebaker
Hudson	Thunderbird
Imperial	Willys

OVER 2½ MILLION COPIES SOLD!
USED BY U.S. ARMED FORCES

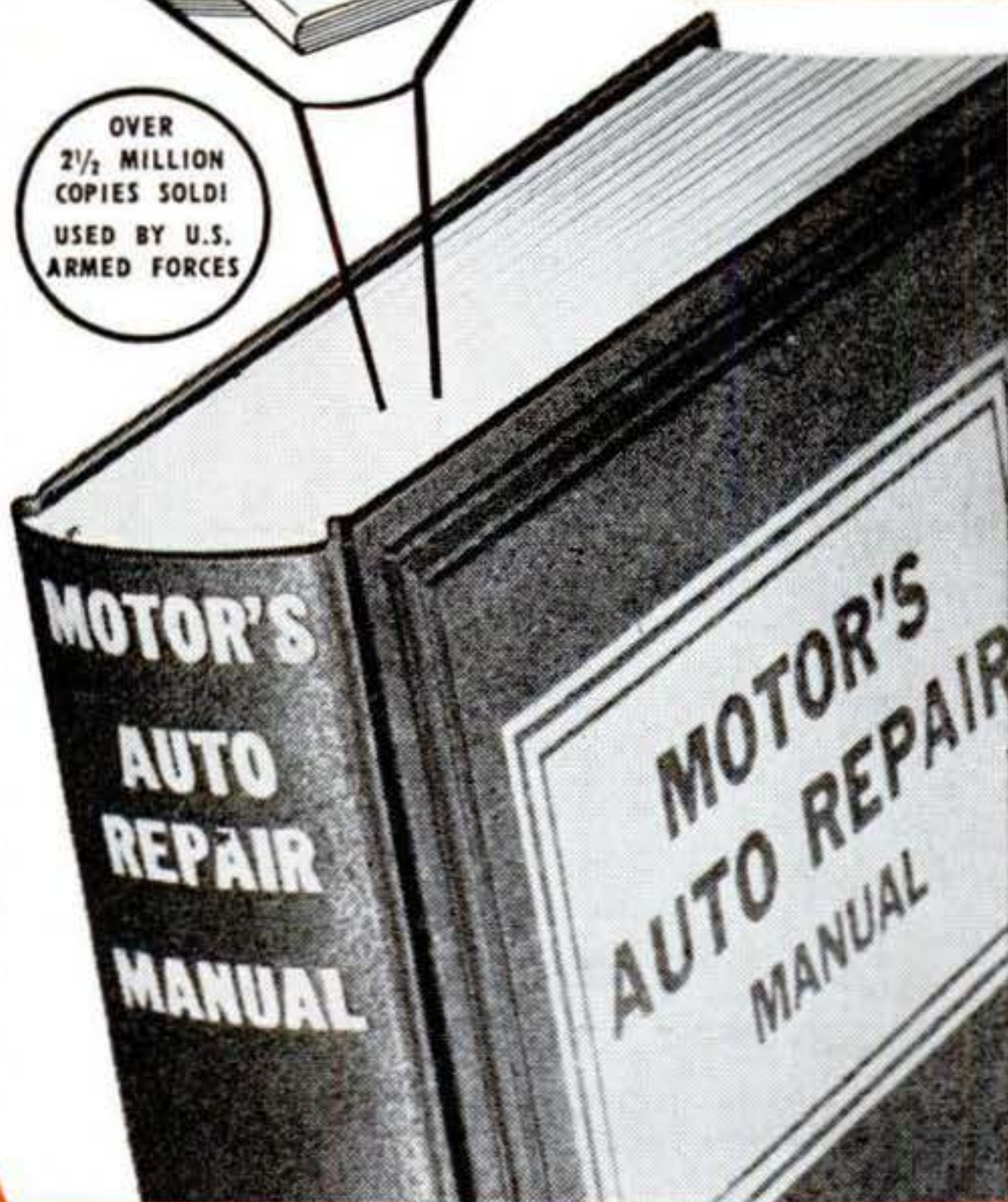

MAIL COUPON NOW FOR 7-DAY FREE TRIAL
(Attach to postcard if more convenient)

MOTOR BOOK DEPT.
Desk 2-G, 250 W. 55th St., New York 19, N. Y.

Rush to me at once (check box opposite book you want):

MOTOR'S New AUTO REPAIR MANUAL. If O.K., I will remit \$2 in 7 days, \$2 monthly for 2 months and a final payment of \$1.95 (plus 35¢ delivery charges) one month after that. Otherwise I will return the book postpaid in 7 days. (Foreign price, remit \$10 cash with order.)

MOTOR'S New TRUCK REPAIR MANUAL. If O.K., I will remit \$3 in 7 days, and \$2 monthly for 3 months, plus 35¢ delivery charges with final payment. Otherwise I will return book postpaid in 7 days. (Foreign price, remit \$11 cash with order.)

Print Name Age.....

Address

City Zone State.....

Check box and save 35¢ shipping charge by enclosing WITH coupon in envelope entire payment of \$7.95 for Auto Repair Manual (or \$9 for Truck Repair Manual). Same 7-day return-refund privilege applies.